



## **Cisco SIP IP Phone Administrator Guide Version 3.0**

January 2002

### **Corporate Headquarters**

Cisco Systems, Inc.  
170 West Tasman Drive  
San Jose, CA 95134-1706  
USA  
<http://www.cisco.com>  
Tel: 408 526-4000  
800 553-NETS (6387)  
Fax: 408 526-4100

Customer Order Number:  
Text Part Number: OL-2206-01

THE SPECIFICATIONS AND INFORMATION REGARDING THE PRODUCTS IN THIS MANUAL ARE SUBJECT TO CHANGE WITHOUT NOTICE. ALL STATEMENTS, INFORMATION, AND RECOMMENDATIONS IN THIS MANUAL ARE BELIEVED TO BE ACCURATE BUT ARE PRESENTED WITHOUT WARRANTY OF ANY KIND, EXPRESS OR IMPLIED. USERS MUST TAKE FULL RESPONSIBILITY FOR THEIR APPLICATION OF ANY PRODUCTS.

THE SOFTWARE LICENSE AND LIMITED WARRANTY FOR THE ACCOMPANYING PRODUCT ARE SET FORTH IN THE INFORMATION PACKET THAT SHIPPED WITH THE PRODUCT AND ARE INCORPORATED HEREIN BY THIS REFERENCE. IF YOU ARE UNABLE TO LOCATE THE SOFTWARE LICENSE OR LIMITED WARRANTY, CONTACT YOUR CISCO REPRESENTATIVE FOR A COPY.

The following information is for FCC compliance of Class A devices: This equipment has been tested and found to comply with the limits for a Class A digital device, pursuant to part 15 of the FCC rules. These limits are designed to provide reasonable protection against harmful interference when the equipment is operated in a commercial environment. This equipment generates, uses, and can radiate radio-frequency energy and, if not installed and used in accordance with the instruction manual, may cause harmful interference to radio communications. Operation of this equipment in a residential area is likely to cause harmful interference, in which case users will be required to correct the interference at their own expense.

The following information is for FCC compliance of Class B devices: The equipment described in this manual generates and may radiate radio-frequency energy. If it is not installed in accordance with Cisco's installation instructions, it may cause interference with radio and television reception. This equipment has been tested and found to comply with the limits for a Class B digital device in accordance with the specifications in part 15 of the FCC rules. These specifications are designed to provide reasonable protection against such interference in a residential installation. However, there is no guarantee that interference will not occur in a particular installation.

Modifying the equipment without Cisco's written authorization may result in the equipment no longer complying with FCC requirements for Class A or Class B digital devices. In that event, your right to use the equipment may be limited by FCC regulations, and you may be required to correct any interference to radio or television communications at your own expense.

You can determine whether your equipment is causing interference by turning it off. If the interference stops, it was probably caused by the Cisco equipment or one of its peripheral devices. If the equipment causes interference to radio or television reception, try to correct the interference by using one or more of the following measures:

- Turn the television or radio antenna until the interference stops.
- Move the equipment to one side or the other of the television or radio.
- Move the equipment farther away from the television or radio.
- Plug the equipment into an outlet that is on a different circuit from the television or radio. (That is, make certain the equipment and the television or radio are on circuits controlled by different circuit breakers or fuses.)

Modifications to this product not authorized by Cisco Systems, Inc. could void the FCC approval and negate your authority to operate the product.

The Cisco implementation of TCP header compression is an adaptation of a program developed by the University of California, Berkeley (UCB) as part of UCB's public domain version of the UNIX operating system. All rights reserved. Copyright © 1981, Regents of the University of California.

NOTWITHSTANDING ANY OTHER WARRANTY HEREIN, ALL DOCUMENT FILES AND SOFTWARE OF THESE SUPPLIERS ARE PROVIDED "AS IS" WITH ALL FAULTS. CISCO AND THE ABOVE-NAMED SUPPLIERS DISCLAIM ALL WARRANTIES, EXPRESSED OR IMPLIED, INCLUDING, WITHOUT LIMITATION, THOSE OF MERCHANTABILITY, FITNESS FOR A PARTICULAR PURPOSE AND NONINFRINGEMENT OR ARISING FROM A COURSE OF DEALING, USAGE, OR TRADE PRACTICE.

IN NO EVENT SHALL CISCO OR ITS SUPPLIERS BE LIABLE FOR ANY INDIRECT, SPECIAL, CONSEQUENTIAL, OR INCIDENTAL DAMAGES, INCLUDING, WITHOUT LIMITATION, LOST PROFITS OR LOSS OR DAMAGE TO DATA ARISING OUT OF THE USE OR INABILITY TO USE THIS MANUAL, EVEN IF CISCO OR ITS SUPPLIERS HAVE BEEN ADVISED OF THE POSSIBILITY OF SUCH DAMAGES.

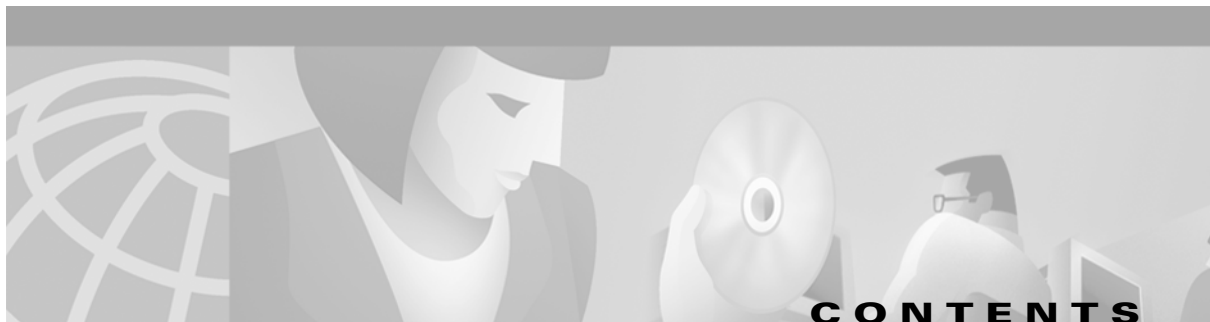

## **Preface vii**

Overview	<b>vii</b>
Who Should Use This Guide	<b>vii</b>
Objectives	<b>viii</b>
Document Organization	<b>viii</b>
Related Documentation	<b>viii</b>
Document Conventions	<b>ix</b>
Obtaining Documentation	<b>xi</b>
World Wide Web	<b>xi</b>
Documentation CD-ROM	<b>xi</b>
Ordering Documentation	<b>xii</b>
Documentation Feedback	<b>xii</b>
Obtaining Technical Assistance	<b>xii</b>
Cisco.com	<b>xii</b>
Technical Assistance Center	<b>xiii</b>
Cisco TAC Web Site	<b>xiii</b>
Cisco TAC Escalation Center	<b>xiv</b>

---

## **CHAPTER 1**

### **Product Overview 1-1**

What Is Session Initiation Protocol?	<b>1-1</b>
Components of SIP	<b>1-2</b>
SIP Clients	<b>1-3</b>
SIP Servers	<b>1-3</b>
What Is the Cisco SIP IP Phone?	<b>1-3</b>
Supported Features	<b>1-5</b>
Physical Features	<b>1-5</b>
Network Features	<b>1-5</b>
Configuration Features	<b>1-5</b>
Codec and Protocol Support	<b>1-6</b>
Dialing and Messaging Features	<b>1-6</b>
Call Options	<b>1-7</b>
Routing and Proxy Features	<b>1-7</b>
Supported Protocols	<b>1-9</b>
Prerequisites	<b>1-10</b>

- Cisco SIP IP Phone Connections **1-10**
  - Connecting to the Network **1-11**
    - Network Port (10/100 SW) **1-11**
    - Access Port (10/100 PC) **1-11**
  - Connecting to Power **1-11**
  - Using a Headset **1-12**
- The Cisco SIP IP Phone with a Catalyst Switch **1-13**

**CHAPTER 2**

**Getting Started with Your Cisco SIP IP Phone 2-1**

- Initialization Process Overview **2-1**
- Installing the Cisco SIP IP Phone **2-2**
  - Installation Task Summary **2-2**
  - Downloading Files to Your TFTP Server **2-3**
  - Configuring SIP Parameters **2-3**
    - Configuring SIP Parameters via a TFTP Server **2-4**
    - Manually Configuring the SIP Parameters **2-7**
  - Configuring Network Parameters **2-9**
    - Configuring Network Parameters via a DHCP Server **2-10**
    - Manually Configuring the Network Parameters **2-10**
- Connecting the Phone **2-11**
  - Adjusting the Placement of the Cisco SIP Phone **2-12**
- Verifying Startup **2-14**
- Using the Cisco SIP IP Phone Menu Interface **2-15**
- Reading the Cisco SIP IP Phone Icons **2-15**
- Customizing the Cisco SIP IP Phone Ring Types **2-17**
- Creating Dial Plans **2-17**

**CHAPTER 3**

**Managing Cisco SIP IP Phones 3-1**

- Changing Your Configuration **3-1**
- Modifying the Phone's Network Settings **3-2**
  - Entering Configuration Mode **3-2**
  - Unlocking Configuration Mode **3-2**
  - Locking Configuration Mode **3-2**
  - Changing the Network Settings **3-2**
- Modifying the Phone's SIP Settings **3-5**
  - Modifying SIP Parameters via a TFTP Server **3-7**
    - Modifying the Default SIP Configuration File **3-8**
    - Modifying the Phone-Specific SIP Configuration File **3-19**

Modifying the SIP Parameters Directly on Your Phone	<b>3-22</b>
Using the Command-Line Interface	<b>3-26</b>
Setting the Date, Time, and Daylight Saving Time	<b>3-31</b>
Erasing the Locally Defined Settings	<b>3-35</b>
Erasing the Locally Defined Network Settings	<b>3-35</b>
Erasing the Locally Defined SIP Settings	<b>3-35</b>
Accessing Status Information	<b>3-36</b>
Viewing Status Messages	<b>3-36</b>
Viewing Network Statistics	<b>3-36</b>
Viewing the Firmware Version	<b>3-37</b>
Upgrading the Cisco SIP IP Phone Firmware	<b>3-38</b>
Upgrading from Release 2.2 or 2.3 to Release 3.0	<b>3-39</b>
Upgrading from Release 2.1 or Earlier Releases to Release 3.0	<b>3-39</b>
Dual Booting from SCCP or MGCP to Release 3.0	<b>3-40</b>
Performing an Image Upgrade and Remote Reboot	<b>3-40</b>

**APPENDIX A****SIP Compliance with RFC 2543 Information A-1**

SIP Functions	<b>A-1</b>
SIP Methods	<b>A-1</b>
SIP Responses	<b>A-2</b>
1xx Response—Information Responses	<b>A-2</b>
2xx Response—Successful Responses	<b>A-3</b>
3xx Response—Redirection Responses	<b>A-3</b>
4xx Response—Request Failure Responses	<b>A-4</b>
5xx Response—Server Failure Responses	<b>A-6</b>
6xx Response—Global Responses	<b>A-7</b>
SIP Header Fields	<b>A-7</b>
SIP Session Description Protocol (SDP) Usage	<b>A-8</b>
Transport Layer Protocols	<b>A-9</b>
SIP Security	<b>A-9</b>
Authentication	<b>A-9</b>
SIP DNS Records Usage	<b>A-9</b>
SIP DTMF Digit Transport	<b>A-9</b>

**APPENDIX B****SIP Call Flows B-1**

Call Flow Scenarios for Successful Calls	<b>B-1</b>
Gateway-to-Cisco SIP IP Phone—Successful Call Setup and Disconnect	<b>B-2</b>
Gateway-to-Cisco SIP IP Phone—Successful Call Setup and Call Hold	<b>B-4</b>

- Cisco SIP IP Phone-to-Cisco SIP IP Phone Simple Call Hold **B-6**
- Cisco SIP IP Phone-to-Cisco SIP IP Phone Call Hold with Consultation **B-9**
- Cisco SIP IP Phone-to-Cisco SIP IP Phone Call Waiting **B-13**
- Cisco SIP IP Phone-to-Cisco SIP IP Phone Call Transfer Without Consultation **B-17**
- Cisco SIP IP Phone-to-Cisco SIP IP Phone Call Transfer Without Consultation Using Failover to Bye/Also **B-21**
- Cisco SIP IP Phone-to-Cisco SIP IP Phone Call Transfer with Consultation **B-25**
- Cisco SIP IP Phone-to-Cisco SIP IP Phone Call Transfer with Consultation Using Failover to Bye/Also **B-30**
- Cisco SIP IP Phone-to-Cisco SIP IP Phone Network Call Forwarding (Unconditional) **B-35**
- Cisco SIP IP Phone-to-Cisco SIP IP Phone Network Call Forwarding (Busy) **B-37**
- Cisco SIP IP Phone-to-Cisco SIP IP Phone Network Call Forwarding (No Answer) **B-39**
- Cisco SIP IP Phone-to-Cisco SIP IP Phone Three-Way Calling **B-42**
- Call Flow Scenarios for Failed Calls **B-46**
  - Gateway-to-Cisco SIP IP Phone—Called User Is Busy **B-46**
  - Gateway-to-Cisco SIP IP Phone—Called User Does Not Answer **B-48**
  - Gateway-to-Cisco SIP IP Phone—Client, Server, or Global Error **B-50**
  - Cisco SIP IP Phone-to-Cisco SIP IP Phone—Called User Is Busy **B-52**
  - Cisco SIP IP Phone-to-Cisco SIP IP Phone—Called User Does Not Answer **B-53**
  - Cisco SIP IP Phone-to-Cisco SIP IP Phone—Authentication Error **B-54**
  - Call from a Cisco SIP IP Phone to a Gateway Acting as a Backup Proxy **B-55**
  - Call from a Cisco SIP IP Phone to a Cisco SIP IP Phone via a Backup Proxy **B-58**
  - Call from a Cisco SIP IP Phone to a Gateway Acting as an Emergency Proxy **B-60**
  - Call from a Cisco SIP IP Phone to a Cisco SIP IP Phone via Emergency Proxy **B-61**

**APPENDIX C**

**Technical Specifications C-1**

- Physical and Operating Environment Specifications **C-1**
- Cable Specifications **C-2**
- Regulatory Safety Compliance **C-2**
- Connections Specifications **C-3**

**APPENDIX D**

**Translated Safety Warnings D-1**

- Installation Warning **D-1**
- Product Disposal Warning **D-1**
- Lightning Activity Warning **D-2**
- SELV Circuit Warning (other versions available) **D-2**
- Circuit Breaker (15A) Warning **D-4**

---

**GLOSSARY**

---

**INDEX**







## Preface

---

This document describes the Cisco SIP IP phone. This chapter describes the objectives and organization of the document and explains how to find additional information on related products and services.

This chapter contains the following sections:

- Overview, page vii
- Who Should Use This Guide, page vii
- Objectives, page viii
- Document Organization, page viii
- Related Documentation, page viii
- Document Conventions, page ix
- Obtaining Documentation, page xi
- Obtaining Technical Assistance, page xii

## Overview

The *Cisco SIP IP Phone Administrator Guide* provides information about how to set up, connect cables to, and configure a Cisco Session Initiation Protocol (SIP) IP phone 7940 or 7960 (hereafter referred to as a Cisco SIP IP phone). It also provides information on how to configure the network and SIP settings and change the settings and options of the Cisco SIP IP phone. The administrator guide also includes reference information such as Cisco SIP IP phone call flows and compliance information.

## Who Should Use This Guide

Network engineers, system administrators, or telecommunications engineers should use this guide to learn the steps required to properly set up the Cisco SIP IP phone on the network.

The tasks described are considered to be administration-level tasks and are not intended for the end users of the phones. Many of the tasks involve configuring network settings that could affect the phone's ability to function in the network and require an understanding of IP networking and telephony concepts.

# Objectives

The *Cisco SIP IP Phone Administrator Guide Version 3.0* provides necessary information to get the Cisco SIP IP phone operational in a Voice-over-IP (VoIP) network.

It is not the intent of this administrator guide to provide information on how to implement a SIP VoIP network. For information on implementing a SIP VoIP network, refer to the documents listed in the “Related Documentation” section on page viii.

# Document Organization

Table 1 lists the chapters and appendixes in this document:

**Table 1** Document Organization

Section	Title	Description
Chapter 1	Product Overview	Describes SIP and the Cisco SIP IP phone.
Chapter 2	Getting Started with Your Cisco SIP IP Phone	Describes how to install, connect, and configure the Cisco SIP IP phone.
Chapter 3	Managing Cisco SIP IP Phones	Describes how to modify the Cisco SIP IP phone’s network and SIP settings, how to access network and call status information, and how to upgrade the firmware.
Appendix A	SIP Compliance with RFC 2543 Information	Provides reference information about the SIP IP phone compliance to RFC 2543.
Appendix B	SIP Call Flows	Provides reference information about the SIP IP phone call flows.
Appendix C	Technical Specifications	Lists the physical and operating environment specifications, cable specifications, and connection specifications
Appendix D	Translated Safety Warnings	Lists translated safety warnings that should be followed when installing an electrical device such as the SIP IP phone.

# Related Documentation

The following is a list of related Cisco SIP VoIP publications. For more information about implementing a SIP VoIP network, refer to the following publications:

- *Session Initiation Protocol Gateway Call Flows*
- *Cisco IP Phone 7960 and 7940 Series At a Glance*
- *Regulatory Compliance and Safety Information for the Cisco IP Phone 7960, 7940, and 7910 Series*
- *Installing the Wall Mount Kit for the Cisco IP Phone*

The following is a list of Cisco VoIP publications that provide information about implementing a VoIP network:

- *Cisco IOS Voice, Video, and Fax Configuration Guide*, Release 12.2
- *Cisco IOS Voice, Video, and Fax Command Reference*, Release 12.2
- *Cisco IOS IP Configuration Guide*, Release 12.2
- *Cisco IOS IP Command Reference, Volume 1 of 3: Addressing and Services*, Release 12.2
- *Cisco IOS IP Command Reference, Volume 2 of 3: Routing Protocols*, Release 12.2
- *Cisco IOS IP Command Reference, Volume 3 of 3: Multicast*, Release 12.2

## Document Conventions

This document uses the following conventions:

- Commands and keywords are in **boldface** font.
- Arguments for which you supply values are in *italic* font.
- Elements in square brackets ([ ]) are optional.
- Alternative keywords are grouped in braces and separated by vertical bars (for example, { **x** | **y** | **z** }).
- Optional alternative keywords are grouped in brackets and separated by vertical bars (for example, [ **x** | **y** | **z** ]).
- Terminal sessions and information the system displays are in `screen` font.
- Information you must enter is in **boldface screen** font.

Notes use the following conventions:



### Note

---

Means *reader take note*. Notes contain helpful suggestions or references to material not covered in the publication.

---

Cautions use the following conventions:



### Caution

---

Means *reader be careful*. In this situation, you might do something that could result in equipment damage or loss of data.

---

Warnings use the following conventions:



**Warning**

This warning symbol means danger. You are in a situation that could cause bodily injury. Before you work on any equipment, be aware of the hazards involved with electrical circuitry and be familiar with standard practices for preventing accidents. (To see translations of the warnings that appear in this publication, refer to the appendix, "Translated Safety Warnings.")

**Waarschuwing**

Dit waarschuwingssymbool betekent gevaar. U verkeert in een situatie die lichamelijk letsel kan veroorzaken. Voordat u aan enige apparatuur gaat werken, dient u zich bewust te zijn van de bij elektrische schakelingen betrokken risico's en dient u op de hoogte te zijn van standaard maatregelen om ongelukken te voorkomen. (Voor vertalingen van de waarschuwingen die in deze publicatie verschijnen, kunt u het aanhangsel "Translated Safety Warnings" (Vertalingen van veiligheidsvoorschriften) raadplegen.)

**Varoitus**

Tämä varoitusmerkki merkitsee vaaraa. Olet tilanteessa, joka voi johtaa ruumiinvammaan. Ennen kuin työskentelet minkään laitteiston parissa, ota selvää sähkökytkentöihin liittyvistä vaaroista ja tavanomaisista onnettomuuksien ehkäisykeinoista. (Tässä julkaisussa esiintyvien varoitusten käännökset löydät liitteestä "Translated Safety Warnings" (käännetyt turvallisuutta koskevat varoitukset).)

**Attention**

Ce symbole d'avertissement indique un danger. Vous vous trouvez dans une situation pouvant entraîner des blessures. Avant d'accéder à cet équipement, soyez conscient des dangers posés par les circuits électriques et familiarisez-vous avec les procédures courantes de prévention des accidents. Pour obtenir les traductions des mises en garde figurant dans cette publication, veuillez consulter l'annexe intitulée « Translated Safety Warnings » (Traduction des avis de sécurité).

**Warnung**

Dieses Warnsymbol bedeutet Gefahr. Sie befinden sich in einer Situation, die zu einer Körperverletzung führen könnte. Bevor Sie mit der Arbeit an irgendeinem Gerät beginnen, seien Sie sich der mit elektrischen Stromkreisen verbundenen Gefahren und der Standardpraktiken zur Vermeidung von Unfällen bewußt. (Übersetzungen der in dieser Veröffentlichung enthaltenen Warnhinweise finden Sie im Anhang mit dem Titel "Translated Safety Warnings" (Übersetzung der Warnhinweise).)

**Avvertenza**

Questo simbolo di avvertenza indica un pericolo. Si è in una situazione che può causare infortuni. Prima di lavorare su qualsiasi apparecchiatura, occorre conoscere i pericoli relativi ai circuiti elettrici ed essere al corrente delle pratiche standard per la prevenzione di incidenti. La traduzione delle avvertenze riportate in questa pubblicazione si trova nell'appendice, "Translated Safety Warnings" (Traduzione delle avvertenze di sicurezza).

**Advarsel**

Dette varselsymbolet betyr fare. Du befinner deg i en situasjon som kan føre til personskade. Før du utfører arbeid på utstyr, må du være oppmerksom på de faremomentene som elektriske kretser innebærer, samt gjøre deg kjent med vanlig praksis når det gjelder å unngå ulykker. (Hvis du vil se oversettelser av de advarslene som finnes i denne publikasjonen, kan du se i vedlegget "Translated Safety Warnings" [Oversatte sikkerhetsadvarsler].)

- Aviso** Este símbolo de aviso indica perigo. Encontra-se numa situação que lhe poderá causar danos físicos. Antes de começar a trabalhar com qualquer equipamento, familiarize-se com os perigos relacionados com circuitos eléctricos, e com quaisquer práticas comuns que possam prevenir possíveis acidentes. (Para ver as traduções dos avisos que constam desta publicação, consulte o apêndice “Translated Safety Warnings” - “Traduções dos Avisos de Segurança”).
- Advertencia** Este símbolo de aviso significa peligro. Existe riesgo para su integridad física. Antes de manipular cualquier equipo, considerar los riesgos que entraña la corriente eléctrica y familiarizarse con los procedimientos estándar de prevención de accidentes. (Para ver traducciones de las advertencias que aparecen en esta publicación, consultar el apéndice titulado “Translated Safety Warnings.”)
- Varning!** Denna varningssymbol signalerar fara. Du befinner dig i en situation som kan leda till personskada. Innan du utför arbete på någon utrustning måste du vara medveten om farorna med elkretsar och känna till vanligt förfarande för att förebygga skador. (Se förklaringar av de varningar som förekommer i denna publikation i appendix "Translated Safety Warnings" [Översatta säkerhetsvarningar].)
- 

## Obtaining Documentation

The following sections explain how to obtain documentation from Cisco Systems.

### World Wide Web

You can access the most current Cisco documentation on the World Wide Web at the following URL:

<http://www.cisco.com>

Translated documentation is available at the following URL:

[http://www.cisco.com/public/countries\\_languages.shtml](http://www.cisco.com/public/countries_languages.shtml)

### Documentation CD-ROM

Cisco documentation and additional literature are available in a Cisco Documentation CD-ROM package, which is shipped with your product. The Documentation CD-ROM is updated monthly and may be more current than printed documentation. The CD-ROM package is available as a single unit or through an annual subscription.

## Ordering Documentation

Cisco documentation is available in the following ways:

- Registered Cisco Direct Customers can order Cisco product documentation from the Networking Products MarketPlace:  
[http://www.cisco.com/cgi-bin/order/order\\_root.pl](http://www.cisco.com/cgi-bin/order/order_root.pl)
- Registered Cisco.com users can order the Documentation CD-ROM through the online Subscription Store:  
<http://www.cisco.com/go/subscription>
- Nonregistered Cisco.com users can order documentation through a local account representative by calling Cisco corporate headquarters (California, USA) at 408 526-7208 or, elsewhere in North America, by calling 800 553-NETS (6387).

## Documentation Feedback

If you are reading Cisco product documentation on Cisco.com, you can submit technical comments electronically. Click **Leave Feedback** at the bottom of the Cisco Documentation home page. After you complete the form, print it out and fax it to Cisco at 408 527-0730.

You can e-mail your comments to [bug-doc@cisco.com](mailto:bug-doc@cisco.com).

To submit your comments by mail, use the response card behind the front cover of your document, or write to the following address:

Cisco Systems  
Attn: Document Resource Connection  
170 West Tasman Drive  
San Jose, CA 95134-9883

We appreciate your comments.

## Obtaining Technical Assistance

Cisco provides Cisco.com as a starting point for all technical assistance. Customers and partners can obtain documentation, troubleshooting tips, and sample configurations from online tools by using the Cisco Technical Assistance Center (TAC) Web Site. Cisco.com registered users have complete access to the technical support resources on the Cisco TAC Web Site.

## Cisco.com

Cisco.com is the foundation of a suite of interactive, networked services that provides immediate, open access to Cisco information, networking solutions, services, programs, and resources at any time, from anywhere in the world.

Cisco.com is a highly integrated Internet application and a powerful, easy-to-use tool that provides a broad range of features and services to help you to

- Streamline business processes and improve productivity
- Resolve technical issues with online support

- Download and test software packages
- Order Cisco learning materials and merchandise
- Register for online skill assessment, training, and certification programs

You can self-register on Cisco.com to obtain customized information and service. To access Cisco.com, go to the following URL:

<http://www.cisco.com>

## Technical Assistance Center

The Cisco TAC is available to all customers who need technical assistance with a Cisco product, technology, or solution. Two types of support are available through the Cisco TAC: the Cisco TAC Web Site and the Cisco TAC Escalation Center.

Inquiries to Cisco TAC are categorized according to the urgency of the issue:

- Priority level 4 (P4)—You need information or assistance concerning Cisco product capabilities, product installation, or basic product configuration.
- Priority level 3 (P3)—Your network performance is degraded. Network functionality is noticeably impaired, but most business operations continue.
- Priority level 2 (P2)—Your production network is severely degraded, affecting significant aspects of business operations. No workaround is available.
- Priority level 1 (P1)—Your production network is down, and a critical impact to business operations will occur if service is not restored quickly. No workaround is available.

Which Cisco TAC resource you choose is based on the priority of the problem and the conditions of service contracts, when applicable.

## Cisco TAC Web Site

The Cisco TAC Web Site allows you to resolve P3 and P4 issues yourself, saving both cost and time. The site provides around-the-clock access to online tools, knowledge bases, and software. To access the Cisco TAC Web Site, go to the following URL:

<http://www.cisco.com/tac>

All customers, partners, and resellers who have a valid Cisco services contract have complete access to the technical support resources on the Cisco TAC Web Site. The Cisco TAC Web Site requires a Cisco.com login ID and password. If you have a valid service contract but do not have a login ID or password, go to the following URL to register:

<http://www.cisco.com/register/>

If you cannot resolve your technical issues by using the Cisco TAC Web Site, and you are a Cisco.com registered user, you can open a case online by using the TAC Case Open tool at the following URL:

<http://www.cisco.com/tac/caseopen>

If you have Internet access, it is recommended that you open P3 and P4 cases through the Cisco TAC Web Site.

## Cisco TAC Escalation Center

The Cisco TAC Escalation Center addresses issues that are classified as priority level 1 or priority level 2; these classifications are assigned when severe network degradation significantly impacts business operations. When you contact the TAC Escalation Center with a P1 or P2 problem, a Cisco TAC engineer will automatically open a case.

To obtain a directory of toll-free Cisco TAC telephone numbers for your country, go to the following URL:

<http://www.cisco.com/warp/public/687/Directory/DirTAC.shtml>

Before calling, please check with your network operations center to determine the level of Cisco support services to which your company is entitled; for example, SMARTnet, SMARTnet Onsite, or Network Supported Accounts (NSA). In addition, please have available your service agreement number and your product serial number.





## Product Overview

---

This chapter contains the following information about the Cisco SIP IP phone:

- What Is Session Initiation Protocol?, page 1-1
- What Is the Cisco SIP IP Phone?, page 1-3
- Prerequisites, page 1-10
- Cisco SIP IP Phone Connections, page 1-10
- The Cisco SIP IP Phone with a Catalyst Switch, page 1-13

## What Is Session Initiation Protocol?

Session Initiation Protocol (SIP) is the Internet Engineering Task Force's (IETF's) standard for multimedia conferencing over IP. SIP is an ASCII-based, application-layer control protocol (defined in RFC 2543) that can be used to establish, maintain, and terminate calls between two or more endpoints.

Like other VoIP protocols, SIP is designed to address the functions of signaling and session management within a packet telephony network. *Signaling* allows call information to be carried across network boundaries. *Session management* provides the ability to control the attributes of an end-to-end call.

SIP provides the capabilities to:

- Determine the location of the target endpoint—SIP supports address resolution, name mapping, and call redirection.
- Determine the media capabilities of the target endpoint—Via Session Description Protocol (SDP), SIP determines the “lowest level” of common services between the endpoints. Conferences are established using only the media capabilities that can be supported by all endpoints.
- Determine the availability of the target endpoint—If a call cannot be completed because the target endpoint is unavailable, SIP determines whether the called party is already on the phone or did not answer in the allotted number of rings. It then returns a message indicating why the target endpoint was unavailable.
- Establish a session between the originating and target endpoint—If the call can be completed, SIP establishes a session between the endpoints. SIP also supports mid-call changes, such as the addition of another endpoint to the conference or the changing of a media characteristic or codec.
- Handle the transfer and termination of calls—SIP supports the transfer of calls from one endpoint to another. During a call transfer, SIP simply establishes a session between the transferee and a new endpoint (specified by the transferring party) and terminates the session between the transferee and the transferring party. At the end of a call, SIP terminates the sessions between all parties.

Conferences can consist of two or more users and can be established using multicast or multiple unicast sessions.

**Note**

The term *conference* means an established session (or *call*) between two or more endpoints. In this document, the terms conference and call are used interchangeably.

## Components of SIP

SIP is a peer-to-peer protocol. The peers in a session are called user agents (UAs). A user agent can function in one of the following roles:

- User agent client (UAC)—A client application that initiates the SIP request.
- User agent server (UAS)—A server application that contacts the user when a SIP request is received and that returns a response on behalf of the user.

Typically, a SIP endpoint is capable of functioning as both a UAC and a UAS, but functions only as one or the other per transaction. Whether the endpoint functions as a UAC or a UAS depends on the UA that initiated the request.

From an architecture standpoint, the physical components of a SIP network can also be grouped into two categories: clients and servers. Figure 1-1 illustrates the architecture of a SIP network.

**Note**

In addition, the SIP servers can interact with other application services, such as Lightweight Directory Access Protocol (LDAP) servers, a database application, or an eXtensible Markup Language (XML) application. These application services provide back-end services such as directory, authentication, and billing services.

**Figure 1-1 SIP Architecture**

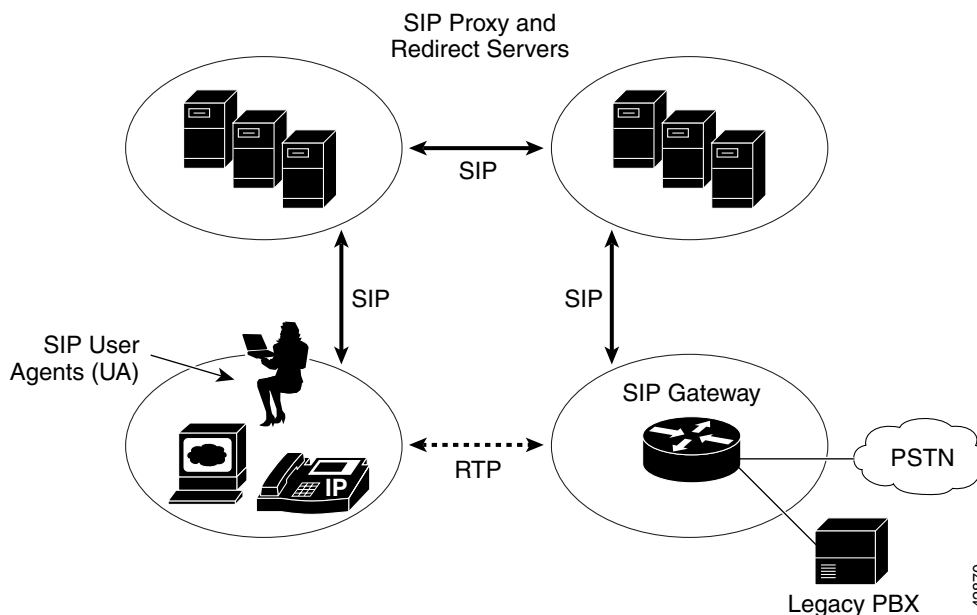

## SIP Clients

SIP clients include:

- **Phones**—Can act as either a UAS or UAC. Softphones (PCs that have phone capabilities installed) and Cisco SIP IP phones can initiate SIP requests and respond to requests.
- **Gateways**—Provide call control. Gateways provide many services, the most common being a translation function between SIP conferencing endpoints and other terminal types. This function includes translation between transmission formats and between communications procedures. In addition, the gateway also translates between audio and video codecs and performs call setup and clearing on both the LAN side and the switched-circuit network side.

## SIP Servers

SIP servers include:

- **Proxy server**—The proxy server is an intermediate device that receives SIP requests from a client and then forwards the requests on the client's behalf. Basically, proxy servers receive SIP messages and forward them to the next SIP server in the network. Proxy servers can provide functions such as authentication, authorization, network access control, routing, reliable request retransmission, and security.
- **Redirect server**—Receives SIP requests, strips out the address in the request, checks its address tables for any other addresses that may be mapped to the one in the request, and then returns the results of the address mapping to the client. Basically, redirect servers provide the client with information about the next hop or hops that a message should take and then the client contacts the next hop server or UAS directly.
- **Registrar server**—Processes requests from UACs for registration of their current location. Registrar servers are often co-located with a redirect or proxy server.

# What Is the Cisco SIP IP Phone?

Cisco SIP IP phones are full-featured telephones that can be plugged directly into an IP network and can be used very much like a standard private branch exchange (PBX) telephone. The Cisco SIP IP phone is an IP telephony instrument that can be used in VoIP networks.

The Cisco SIP IP phone model terminals can attach to the existing data network infrastructure, via 10BASE-T/100BASE-T interfaces on an Ethernet switch. When used with a voice-capable Ethernet switch (one that understands type of service [ToS] bits and can prioritize VoIP traffic), the phones eliminate the need for a traditional proprietary telephone set and key system and PBX.

The Cisco SIP IP phone complies with RFC 2543.

Figure 1-2 illustrates physical features of the Cisco SIP IP phone:

**Figure 1-2 Cisco SIP IP Phone Physical Features**

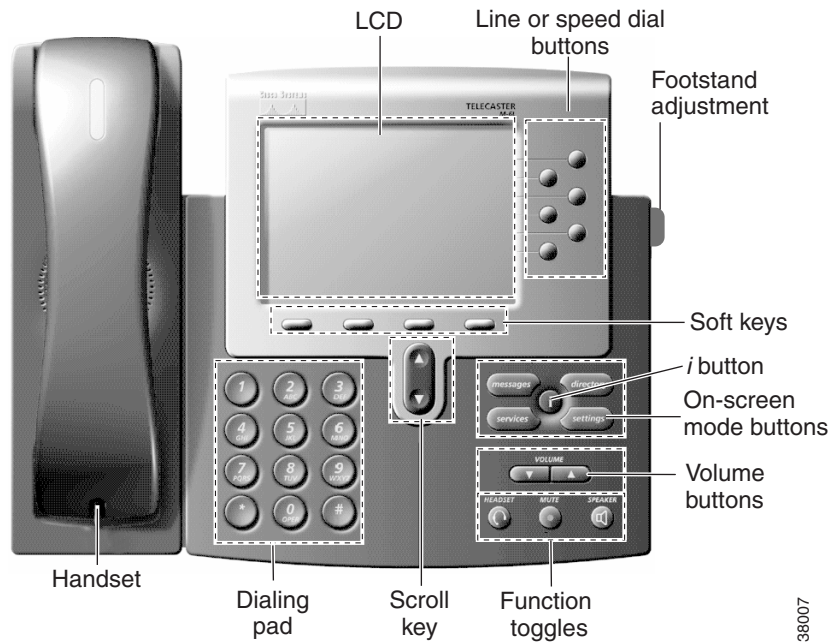

- LCD screen—Desktop, which displays information about your Cisco SIP IP phone, such as the time, date, your phone number, caller ID, line and call status and the soft key tabs.
- Line or speed-dial buttons—Opens a new line or speed dials the number on the LCD screen.
- Footstand adjustment—Adjusts the angle of the phone base.
- Soft keys—Activate the feature described by the text message directly above on the LCD screen.
- Information (*i*) button—Provides online help for selected keys or features and network statistics about the active call.
- On-screen mode buttons—Retrieves information about current settings, recent calls, available services, and voice-mail messages.
- Volume buttons—Adjust the volume of the handset, headset, speaker, and ringer and adjust the brightness contrast settings on the LCD screen.
- Function toggles—Includes these options:
  - Headset and speaker—Toggles these functions enabling you to answer the phone using a headset or speakerphone.
  - Mute—Stops or resumes voice transmission.
- Scroll key—Enables you to move among different soft key options displayed on LCD screen.
- Dialing pad—Press the dial-pad buttons to dial a phone number. Dial-pad buttons work exactly like those on your existing telephone.
- Handset—Lift the handset and press the dial-pad numbers to place a call, review voice-mail messages, and answer a call.

## Supported Features

In addition to the features illustrated in Figure 1-2, the Cisco SIP IP phone also provides the following features.

### Physical Features

- Adjustable ring tone
- Hearing-aid compatible handset
- Headset compatibility
- Integrated two-port Ethernet switch that allows the telephone and a computer to share a single Ethernet jack
- Direct connection to a 10BASE-T or 100BASE-T Ethernet (RJ-45) network (half- or full-duplex connections are supported)
- Large (4.25 x 3 in. or 10.79 cm. x 7.62 cm.) display with adjustable contrast

### Network Features

- IP address assignment—Dynamic Host Configuration Protocol (DHCP) client or manually configured via a local setup menu.
- Network startup using DHCP and Trivial File Transfer Protocol (TFTP).
- Telnet support—Allows the user to use Telnet to connect directly to the Cisco SIP IP phone to debug and troubleshoot the phone. See the “Managing Cisco SIP IP Phones” section on page 3-1 for more information on configuration parameters.
- Ping support—Allows the user to use ping to see if a Cisco SIP IP phone is operational and how long the response time is from the phone.
- Traceroute support—Allows the user to use traceroute to see the path that a Cisco SIP IP phone traverses in the route to its desired destination.

### Configuration Features

The Cisco SIP IP Phone provides the ability to:

- Configure Ethernet port mode and speed
- Register with or unregister from a proxy server
- Specify a TFTP boot directory
- Configure a label for phone identification display purposes
- Configure a name for caller identification purposes for each active line on a phone
- Configure a 12- or 24-hour user interface time display

## Codec and Protocol Support

- G.711 (u-law and a-law) and G.729a audio compression.
- In-band dual tone multifrequency (DTMF) support for touch-tone dialing.
- Out-of-band DTMF signaling for codecs that do not transport the DTMF signaling correctly (for example, G.729 or G.729a).
- Local or remote (using the SIP 183 Ringing message) call progress tone.
- Audio/Video Transport (AVT) payload type negotiation.
- Current date and time support via Simple Network Time Protocol (SNTP) and time zone and Daylight Saving Time support.
- Call redirection information support via the Diversion header.
- Third-party call control via delayed media negotiation. A delayed media negotiation is one where the Session Description Protocol (SDP) information is not completely advertised in the initial call setup.
- Support for endpoints specified as fully qualified domain names (FQDNs) in the SDP.
- Remote reset support (via the Event header in NOTIFY messages).

**Note**

---

See the “Supported Protocols” section on page 1-9 for additional supported protocols.

---

## Dialing and Messaging Features

- Dial plan support that enables automatic dialing and automatic generation of a secondary dial tone
- Local directory configuration (save and recall) and automatic dial completion—Each time a call is successfully made or received, the number is stored in a local directory that is maintained on the phone. The maximum number of entries is 32. Entries are aged-out based on their usage and age. The oldest entry called the least number of times is overwritten first. This feature cannot be programmed by the user, however, up to 20 entries can be “locked” (via the Locked soft key) so that they will never be deleted.
- Message Waiting Indication (via unsolicited NOTIFY)—Lights to indicate that a new voice message is in a subscriber’s mailbox. If the subscriber listens to the message but does not save or delete the message, the light remains on. If a subscriber listens to the new message or messages, and saves or deletes them, the light goes off. The message waiting indicator is controlled by the voicemail server. The indication will be saved over a phone upgrade or reboot.
- Speed dial to voice-mail via the messages button
- Do not disturb—Allows the user to instruct the system to intercept incoming calls during specified periods of time when the user does not want to be disturbed.
- Multiple directory numbers—Allows the Cisco SIP IP phone to have up to six directory numbers or lines.
- Call waiting (enabled)—Plays an audible tone to indicate that an incoming call is waiting. The user can then put the existing call on hold and accept the other call. The user can alternate between the two calls.
- Call waiting (disabled)—Allows the user to instruct the system to block call waiting calls during a specified period of time.

- Direct number dialing—Allows users to initiate or receive a call using a standard E.164 number format in a local, national, or international format.
- Direct URL dialing—Provides the ability to place a call using an e-mail address instead of a phone number.
- Caller ID blocking—Allows the user to instruct the system to block phone number or e-mail address from phones that have caller identification capabilities.
- Anonymous call blocking—Allows the user to instruct the system to block any calls for which the identification is blocked.
- Three-way conferencing—Supports one phone conferencing with two other phones by providing mixing on the initiating phone. To set up a three-way conference call, see the “Making Conference Calls” section in chapter 3 of the *Cisco IP Phone Models 7960 and 7940 User Guide*.

## Call Options

- Call forward (network)—Allows the Cisco SIP IP phone user to request forwarding service from the network (via a third-party tool that enables this feature to be configured). When a call is placed to the user’s phone, it is redirected to the appropriate forward destination by the SIP proxy server.
- Call hold—Allows the Cisco SIP IP phone user (user A) to place a call (from user B) on hold. When user A places user B on hold, the two-way RTP voice path between user A and user B is temporarily disconnected, but the call session is still connected. When user A takes user B off hold, the two-way RTP voice path is reestablished.
- Call transfer—Allows the Cisco SIP IP phone user (user A) to transfer a call from one user (user B) to another user (user C). User A places user B on hold and calls user C. If user C accepts the transfer, a session is established between user B and user C and the session between user A and user B is terminated.
- Three-way calling—Allows a “bridged” three-way call. When a three-way call is established, the Cisco SIP IP phone through which the call is established acts as a bridge, mixing the audio media for the other parties.

## Routing and Proxy Features

- User-defined proxy routing

The Route attribute of the template tag in the dial-plan template file can be used to indicate which proxy (default, emergency, FQDN) that the call should be initially routed to. For example, to configure an emergency proxy, specify value of the Route attribute as “emergency.”

- Backup SIP proxy

When the primary proxy does not respond to the INVITE message sent by the Cisco SIP IP Phone after the configured number of retries, the Cisco SIP IP Phone sends the INVITE to the backup proxy. This is independent from the proxy defined in the Route attribute in the dial-plan template used.

The Cisco SIP IP phone does not have to register with the backup proxy. All interactions with the backup proxy, such as authentication challenges, are treated the same as the interactions with the primary proxy.

The backup proxy is used only with new INVITE messages. Once the backup proxy is used, it is active for the duration of the call.

The location of the backup SIP proxy can be defined as an IP address in the default configuration file. See the `proxy_backup` and `proxy_backup_port` parameters in the “Modifying the Default SIP Configuration File” section on page 3-8.

- Emergency SIP proxy

An optional emergency SIP proxy can be configured with the `Route` attribute of the template tag in the dial-plan template file. See “Support of user-defined proxy routing.”

When an emergency SIP proxy is configured and a call is initiated, the phone generates an INVITE message to the address specified in the `proxy_emergency` parameter. The emergency proxy is used for the call duration.

The location of the emergency proxy can be defined as an IP address in the default configuration file. See the `proxy_emergency` and `proxy_emergency_port` parameters in “Modifying the Default SIP Configuration File” section on page 3-8.

- Support of DNS SRV

The Domain Name Server RR (DNS SRV) is used to locate servers for a given service.

SIP on Cisco’s SIP IP phones uses a DNS SRV query to determine the IP address of the SIP proxy or redirect server. The query string generated is in compliance with RFC 2782, and prepends the protocol label with an underscore `_`, as in “`_protocol._transport`.” The addition of the underscore reduces the risk of the same name being used for unrelated purposes.

In compliance with RFC 2782 and the draft-ietf-sip-srv-01 specification, the system can remember multiple IP addresses and use them properly. In the draft-ietf-sip-srv-01 specification, it is assumed that all proxies returned for the SRV record are equivalent such that the phone can register with any of the proxies and initiate a call using any other proxy.

- Configurable Voice Activity Detection

Voice Activity Detection (VAD) can be enabled or disabled with `enable_vad` parameter. Use a value of 0 to disable, and a value of 1 to enable. See `enable_vad` parameter in “Modifying the Default SIP Configuration File” section on page 3-8.

- Distinctive Alerting

If the INVITE message contains an Alert-Info header, distinctive ringing is invoked. The format of the header is “Alert-info: x”. The value of “x” can be any number. This header is only received by the phone and is not generated by the phone.

Distinctive ringing is supported when the phone is idle or during a call. In the idle mode, the phone rings with a different cadence. The selected ringing type plays twice with a short pause in between. In call-waiting mode, two short beeps are generated instead of one long beep.

- Network Address Translation (NAT) and Outbound Proxy

NAT can be enabled or disabled with the `nat_enable` parameter. You can configure the address of the NAT or firewall server using the `nat_address` parameter.

You can configure the IP address and port number of the outbound proxy server. When outbound proxy is enabled, all SIP requests are sent to the outbound proxy server instead of the `proxyN_address`. All responses continue to follow the using the normal Via processing rules. The media stream is not routed through the outbound proxy.



NAT and outbound proxy modes can be independently enabled or disabled. The received= tag is added to the Via header of all responses if there is no received= tag in the uppermost Via header and the source IP address is different from the IP address in the uppermost Via header. Responses are sent back to the source under the following conditions:

- If a received= tag is in the uppermost Via header, the response is sent back to the IP address contained in the received= tag.
- If there is no received= tag and the IP address in the uppermost Via header is different than the source IP address, the response is sent back to the source IP. Otherwise the response is sent back to the IP address in the uppermost Via header.

**Note**

For information on how to use the standard telephony features and URL dialing, refer to the documents listed in the “Related Documentation” section on page -viii.

## Supported Protocols

The Cisco SIP IP phone supports the following standard protocols:

- Domain Name System (DNS)—Used in the Internet for translating names of network nodes into addresses. SIP uses DNS to resolve the host names of endpoints to IP addresses.
- Dynamic Host Control Protocol (DHCP)—Used to dynamically allocate and assign IP addresses. DHCP allows you to move network devices from one subnet to another without administrative attention. If using DHCP, you can connect Cisco SIP IP phones to the network and become operational without having to manually assign an IP address and additional network parameters.

The Cisco SIP IP phone complies with the DHCP specifications documented in RFC 2131. By default, Cisco SIP IP phones are DHCP-enabled.

- Internet Control Message Protocol (ICMP)—A network layer Internet protocol that enables hosts to send error or control messages to other hosts. ICMP also provides other information relevant to IP packet processing.

The Cisco SIP supports ICMP as it is documented in RFC 792.

- Internet Protocol (IP)—A network layer protocol that sends datagram packets between nodes on the Internet. IP also provides features for addressing, type-of-service (ToS) specification, fragmentation and reassembly, and security.

The Cisco SIP IP phone supports IP as it is defined in RFC 791.

- Real-Time Transport Protocol (RTP)—Transports real-time data (such as voice data) over data networks. RTP also has the ability to obtain quality of service (QoS) information.

The Cisco SIP IP phone supports RTP as a media channel.

- Session Description Protocol (SDP)—An ASCII-based protocol that describes multimedia sessions and their related scheduling information.

The Cisco SIP IP phone uses SDP for session description.

- Simple Network Time Protocol (SNTP)—Synchronizes computer clocks on an IP network. The Cisco SIP IP phones use SNTP for their date and time support.
- Transmission Control Protocol (TCP)—Provides a reliable byte-stream transfer service between two endpoints on an internet. The Cisco SIP IP phone supports TCP for Telnet sessions only.

- Trivial File Transfer Protocol (TFTP)—Allows files to be transferred from one computer to another over a network. The Cisco SIP IP phone uses TFTP to download configuration files and software updates.
- User Datagram Protocol (UDP)—A simple protocol that exchanges data packets without acknowledgments or guaranteed delivery. SIP can use UDP as the underlying transport protocol. If UDP is used, retransmissions are used to ensure reliability.

The Cisco SIP IP phone supports UDP as it is defined in RFC 768 for SIP signaling.

## Prerequisites

For the Cisco SIP IP phone to successfully operate as a SIP endpoint in your network, your network must meet the following requirements:

- A working IP network is established.  
For more information about configuring IP, refer to *Cisco IOS IP Configuration Guide*, Release 12.2.
- VoIP is configured on your Cisco routers.  
For more information about configuring VoIP, refer to the *Cisco IOS Voice, Video, and Fax Configuration Guide*, Release 12.2, for the appropriate access platform. For more information about configuring SIP VoIP, refer to the “Configuring SIP for VoIP” chapter.
- VoIP gateways are configured for SIP.
- A TFTP server is active and contains the latest Cisco SIP IP phone firmware image in its root directory.
- A proxy server is active and configured to receive and forward SIP messages.

## Cisco SIP IP Phone Connections

The Cisco SIP IP phone has connections for connecting to the data network, for providing power to the phone, and for connecting a headset to the phone. Figure 1-3 illustrates the connections on the Cisco SIP IP phone.

Figure 1-3 Cisco SIP IP Phone Cable Connections

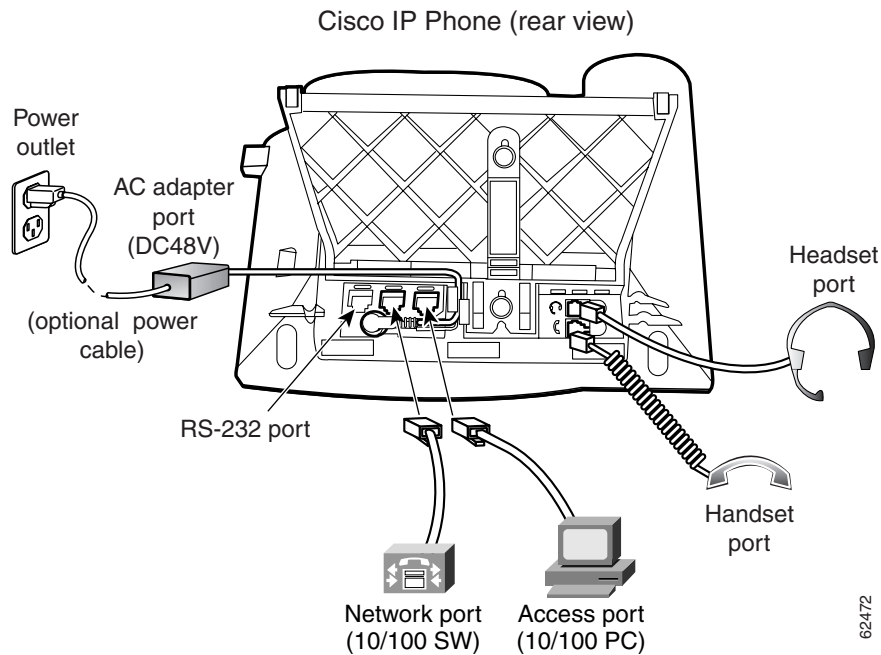

## Connecting to the Network

The Cisco SIP IP phone has two RJ-45 ports that each support 10/100 Mbps half- or full-duplex Ethernet connections to external devices—network port (labeled 10/100 SW) and access port (labeled 10/100 PC). You can use either Category 3 or 5 cabling for 10 Mbps connections, but use Category 5 for 100 Mbps connections. On both the network port and access port, use full-duplex mode to avoid collisions.

### Network Port (10/100 SW)

Use the network port to connect the phone to the network. You must use a straight-through cable on this port. The phone can also obtain inline power from the Catalyst switch over this connection. See the “Connecting to Power” section on page 1-11 for details.

### Access Port (10/100 PC)

Use the access port to connect a network device, such as a computer, to the phone. You must use a straight-through cable on this port.

## Connecting to Power

The Cisco SIP IP phone can be powered by the following sources:

- External power source—Optional Cisco AC adapter and power cord for connecting to a standard wall receptacle.

- WS-X6348-RJ45V 10/100 switching module—Provides inline power to the Cisco SIP IP phone when connected to a Catalyst 3500, 4000, or 6000 family 10/100BASE-TX switching module.  
This module sends power on pins 1 and 2, and 3 and 6.
- WS-PWR-PANEL—Power patch panel provides power to the Cisco SIP IP phone, which allows the Cisco SIP IP phone to be connected to existing Catalyst 4000, 5000, and 6000 family 10/100BASE-TX switching modules.  
This module sends power on pins 4, 5, 7, and 8.
- WS-X4148-RJ45V—48-port 10/100 Ethernet with inline power module for the Catalyst 4006.
- WS-X4095-PEM—VoIP DC Power Entry module for the Catalyst 4006.
- WS-X4608-2PSU and WS-X4608—External -48V DC power shelf common equipment for the Catalyst 4006 with two AC-to-DC power supply units (PSUs) and one empty bay for redundant option, and the 110V 15A AC-to-48V DC PSU redundant option for the power shelf.
- WS-C3524-PWR-XL-EN—Catalyst 3524-PWR XL switch.



---

**Note** Only the network port (labeled 10/100 SW) supports inline power from the Catalyst switches.

---

For redundancy, you can use the Cisco AC adapter even if you are using inline power from the Catalyst switches. The Cisco SIP IP phone can share the power load being used from the inline power and external power source. If either the inline power or the external power goes down, the phone can switch entirely to the other power source.

To use this redundancy feature you *must* set the inline power mode to auto on the Cisco Catalyst switch. Next, connect the unpowered Cisco SIP IP phone to the network. After the phone powers up, connect the external power supply to the phone.

## Using a Headset

The Cisco SIP IP phone supports a four- or six-wire headset jack. Specifically, the Cisco SIP IP phone supports the following Plantronics headset models:

- Tristar Monaural
- Encore Monaural H91
- Encore Binaural H101

The volume and mute controls also adjust volume to the earpiece and mute the speech path of the headset. The headset activation key is located on the front of the Cisco SIP IP phone.



---

**Note** When using a headset, an amplifier is not required. However, a coil cord is required to connect the headset to the headset port on the back of your Cisco IP Phone 7960/7940. For information on ordering compatible headsets and coil cords for the Cisco IP Phone 7960/7460, go to the following URL: <http://cisco.getheadsets.com> or <http://vxicorp.com/cisco>

---

# The Cisco SIP IP Phone with a Catalyst Switch

To function in the IP telephony network, the Cisco SIP IP phone must be connected to a networking device, such as a Catalyst switch, to obtain network connectivity.

The Cisco SIP IP phone has an internal Ethernet switch, which enables it to switch traffic coming from the phone, access port, and the network port.

If a computer is connected to the access port, packets traveling to and from the computer and to and from the phone share the same physical link to the switch and the same port on the switch.

This configuration has these implications for the VLAN configuration on the network:

- The current VLANs might be configured on an IP subnet basis, and additional IP addresses might not be available to assign the phone to a port so that it belongs to the same subnet as other devices (PC) connected to the same port.
- Data traffic present on the VLAN supporting phones might reduce the quality of VoIP traffic.

You can resolve these issues by isolating the voice traffic onto a separate VLAN on each of the ports connected to a phone. The switch port configured for connecting a phone would have separate VLANs configured for carrying:

- Voice traffic to and from the Cisco SIP IP phone (auxiliary VLAN)
- Data traffic to and from the PC connected to the switch through the access port of the Cisco SIP IP phone (native VLAN)

Isolating the phones on a separate, auxiliary VLAN increases the quality of the voice traffic and allows a large number of phones to be added to an existing network where there are not enough IP addresses.

For more information, refer to the documentation included with the Catalyst switch or available online at the following URL:

<http://www.cisco.com/univercd/home/home.htm>





## Getting Started with Your Cisco SIP IP Phone

---

This chapter explains the Cisco SIP IP phone initialization and the process that you should follow to install and connect the Cisco SIP IP phone.

This chapter provides the following major sections:

- Initialization Process Overview, page 2-1
- Installing the Cisco SIP IP Phone, page 2-2
- Verifying Startup, page 2-14
- Using the Cisco SIP IP Phone Menu Interface, page 2-15
- Reading the Cisco SIP IP Phone Icons, page 2-15
- Customizing the Cisco SIP IP Phone Ring Types, page 2-17
- Creating Dial Plans, page 2-17

### Initialization Process Overview

The initialization process of the Cisco SIP IP phone is responsible for establishing network connectivity and for making the phone operational in your IP network.

Once you connect your phone to the network and to an electrical supply, the phone begins its initialization process.

During the initialization process, the following events take place:

1. The stored image is loaded.

The Cisco SIP IP phone has nonvolatile Flash memory in which it stores the firmware images, user-defined preferences, and permanent factory information about the phone.

During initialization, the phone runs a bootstrap loader that loads and executes the phone image stored in Flash memory.

2. The VLAN is configured.

If the Cisco SIP IP phone is connected to a Catalyst switch, the switch notifies the phone of the voice VLAN defined on the switch. The phone needs to know its VLAN membership before it can proceed with the Dynamic Host Configuration Protocol (DHCP) request for its IP settings (if using DHCP).

3. An IP address is acquired.

If the Cisco SIP IP phone is using DHCP to obtain the IP settings, the phone queries the DHCP server. If the phone is not using DHCP, then the phone uses IP settings that are stored in Flash memory.

4. The TFTP server is contacted.

The TFTP server contains the latest Cisco SIP IP phone firmware image and the dual boot file (OS79XX.TXT) that enables the phone to automatically determine and initialize for the VoIP environment in which it is being installed.

If the phone is using the TFTP server to obtain its SIP parameters, there should also be a configuration file or files on the TFTP server that the phone will request and download. In the configuration file or files, SIP parameters that are required by the phone to operate in a SIP VoIP environment are defined. If the phone is not obtaining its SIP parameters via the TFTP server, the phone uses SIP settings that are stored in Flash memory.

5. The firmware version is verified.

If the phone is obtaining its SIP parameters via a TFTP server, the configuration files are requested. If the phone determines that the image defined in a configuration file differs from the image it has stored in Flash memory, it performs a firmware upgrade.

When performing a firmware upgrade, the phone downloads the firmware image from the TFTP server, programs the image into Flash memory, and reboots.

## Installing the Cisco SIP IP Phone

This section contains information on how to install Cisco SIP IP phones in your IP network. Before getting started, read over the information in this section carefully.

### Installation Task Summary

To successfully install the Cisco SIP IP phone, complete the following tasks:

- 
- Step 1** Download the required files from Cisco.com to the TFTP server as described in the “Downloading Files to Your TFTP Server” section on page 2-3.
  - Step 2** If you are configuring SIP parameters via a TFTP server, create and store the configuration files as described in the “Configuring SIP Parameters via a TFTP Server” section on page 2-4.
  - Step 3** If you are using DHCP to configure the phones’ network settings, configure the required network parameters on your DHCP server as described in the “Configuring Network Parameters via a DHCP Server” section on page 2-10.
  - Step 4** Connect the phone to the network and to a power supply as described in the “Connecting the Phone” section on page 2-11.
  - Step 5** If you are not using DHCP to configure network parameters, manually configure the required network parameters as described in the “Manually Configuring the Network Parameters” section on page 2-10.
  - Step 6** If you are not configuring the SIP parameters via a TFTP server, manually configure the required parameters as described in the “Manually Configuring the SIP Parameters” section on page 2-7.
-



## Downloading Files to Your TFTP Server

Before installing the Cisco SIP IP phones, copy the following files from Cisco.com to the root directory of your TFTP server.

File	Required or Optional	Description
OS79XX.TXT	Required	Enables the phone to automatically determine and initialize for the VoIP environment in which it is being installed.  After downloading this file, you must use an ASCII editor to open it and specify the file name (without the file extension) of the image version that you plan to run on your phones.
SIPDefaultGeneric.cnf	Optional	File in which to configure SIP parameters intended for all phones.  For more information on using the SIPDefault.cnf file, see the “Creating the Default SIP Configuration File” section on page 2-5.
SIPConfigGeneric.cnf	Required	File that can be used as a template to configure SIP parameters specific to a phone. When customized for a phone, this file must be renamed to the MAC address of the phone.
RINGLIST.DAT	Optional	Lists audio files that are the custom ring type options for the phones. The audio files listed in the RINGLIST.DAT file must also be in the root directory of the TFTP server.  For more information on custom ring types, see the “Customizing the Cisco SIP IP Phone Ring Types” section on page 2-17.
POS3 <sub>xx</sub> yy.bin	Required	The Cisco SIP IP phone firmware image. The <i>xx</i> variable represents the version number, and <i>yy</i> is the sub-version number. <b>Note</b> Applies to Cisco SIP IP Phone Release 2.3 and earlier.
POS3- <i>xx</i> - <i>y</i> - <i>zz</i> .bin	Required	The Cisco SIP IP phone firmware image. The <i>xx</i> variable represents the major version number, <i>y</i> is the minor version number, and <i>zz</i> is the sub-version number. <b>Note</b> Applies to Cisco SIP IP Phone Release 3.0 and later.
dialplan.xml	Optional	North American sample dial plan.
syncinfo.xml	Optional	Controls the image version and associated synchronization value to be used for remote reboots.

## Configuring SIP Parameters



### Note

This section describes how to configure the basic SIP parameters that are required for the phone to operate in a SIP VoIP environment. For a complete list of the SIP parameters that you can configure, see the “Modifying the Phone’s SIP Settings” section on page 3-5.

The SIP parameters are those parameters that a Cisco SIP IP phone needs to operate in a SIP VoIP environment. You can configure SIP parameters via a TFTP server, or you can manually configure the parameters on a phone-by-phone basis after connecting the phones.

When the phone initializes, it loads the parameters stored in Flash memory. After loading the parameters stored in Flash memory, the phone requests the default configuration file from the TFTP server. If the default configuration file has been configured and stored in the root directory of the TFTP server, the phone reads the parameters defined in the file, and stores those parameters that differ in Flash memory. The phone then requests its phone-specific configuration file. If the phone-specific configuration file has been configured and placed on the TFTP server (in the root directory or a subdirectory), the phone reads the parameters defined in the file and stores those parameters that differ in Flash memory.

Therefore, when configuring SIP parameters, remember the following:

- Parameters defined in the default configuration file override the values stored in Flash memory.
- Parameters defined in the phone-specific configuration file override the values specified in the default configuration file.
- Parameters entered locally are used by the phone until the next reboot (if a phone-specific configuration file exists).
- If you choose not to configure the phone via a TFTP server, you must manage the phone locally.

## Configuring SIP Parameters via a TFTP Server

If you are configuring SIP parameters via a TFTP server, you must use configuration files.

There are two configuration files that you can use to define the SIP parameters; the default configuration file (optional) and the phone-specific configuration file (required). If you choose to use a default configuration file, you must store the file in the root directory of your TFTP server. Phone-specific configuration files can be stored in the root directory or in a subdirectory in which all phone-specific configuration files are stored.

Except for parameters used to define the lines and users on a phone, all other SIP parameters can be defined in either the default configuration file or the phone-specific configuration file. However, for network control and maintenance purposes, we recommend that you define the parameters that you want to apply to all phones in the default configuration file (SIPDefault.cnf). Phone-specific parameters should only be defined via a phone-specific configuration file or be manually configured. Phone-specific parameters should not be defined in the default configuration file.

### Configuration File Guidelines

When modifying the default configuration file and creating the phone-specific configuration files, adhere to the following guidelines and requirements:

- SIP parameters specified in the default configuration file (SIPDefault.cnf) override those parameters stored in Flash memory. Parameters specified in a phone-specific configuration file override those stored in Flash memory and parameters specified in the default configuration file.
- The name of each phone's phone-specific configuration file is unique and is based on the MAC address of the phone.

The format of the file name must be SIPXXXXYYYYZZZZ.cnf, where XXXXYYYYZZZZ is the MAC address of the phone. The MAC address must be in uppercase, and the cnf extension must be in lowercase (for example, SIP00503EFFD842.cnf).



---

**Note** The MAC address of a phone is identified on the middle sticker adhered to the base of the phone and can also be viewed on the Network Configuration menu.

---

- The default configuration file must be stored in the root directory of the TFTP server. The phone-specific configuration file can be stored in the root directory or in a subdirectory in which all phone-specific configuration files are located.
- Each line in the configuration files must use the following format:  

```
variable-name : value ; optional comments
```
- Use colons to separate variable names and values.
- Only one value can be associated with a variable.
- The variable and value can contain white space before or after them and can contain any characters. However, if white spaces are needed within the value, the value must be enclosed in single or double quotes. If the value is enclosed in quotes, the end quote must be the same as the start quote.
- After the value, you can include optional comments. Use the semicolon (;) and pound (#) delimiters to distinguish the comments.
- Blank lines are allowed.
- Comment lines are allowed.
- Variable names are not case sensitive.
- Only one variable can be set per line.
- Distinguish the end of a line using <lf> or <cr><lf>.
- The variable and value must be on the same line and cannot break the line.
- Except for parameters used to defined the lines and users on a phone, all other SIP parameters can be defined in either the default configuration file or the phone-specific configuration file. However, for network control and maintenance purposes, Cisco recommends that you define the parameters that you want to apply to all phones in the default configuration file (SIPDefault.cnf).

### Creating the Default SIP Configuration File

In the default configuration file (SIPDefault.cnf), Cisco recommends that you define the SIP parameters that will be common to all of your phones such as the `image_version` parameter and call environment parameters (for example, you will want to consider if the phones are required to register with a proxy server, and which codec the phones will use when initiating a call).

By maintaining these parameters in the default configuration file, you can perform global changes, such as upgrading the image version, without having to modify the phone-specific configuration file for each phone.

#### Before You Begin

- Ensure that you have downloaded the SIPDefault.cnf file from Cisco.com to the root directory of your TFTP server.
- Review the guidelines and restrictions documented in the “Configuration File Guidelines” section on page 2-4.
- For a complete list of the SIP parameters that you can configure, see the “Modifying the Phone’s SIP Settings” section on page 3-5.

**Procedure**

- 
- Step 1** Using an ASCII editor, open the SIPDefault.cnf file and define values for the following SIP global parameters:
- `image_version`—(Required) Firmware version that the Cisco SIP IP phone should run.  
Enter the name of the image version (as it is released by Cisco). Do not enter the extension. You cannot change the image version by changing the file name, because the version is also built into the file header. Trying to change the image version by changing the file name causes the firmware to fail when it compares the version in the header against the file name.
  - `proxy1_address`—(Required) IP address of the primary SIP proxy server that will be used by the phones.
  - `tftp_cfg_dir`—(Required if phone-specific configuration files are located in a subdirectory) Path to the TFTP subdirectory in which phone-specific configuration files are stored.
- Step 2** Save the file with the same file name, SIPDefault.cnf, to the root directory of your TFTP server.
- 

The following is an example of a SIP default configuration file:

```
; sip default configuration file

#Image Version
image_version:POS3-xx-y-zz ;

#Proxy server address
proxy1_address: 192.168.1.1 ;

#Subdirectory config file location
tftp_cfg_dir: /tftpboot/configs/sipphone
```

**Creating the Phone-Specific SIP Configuration File**

In the phone-specific SIP configuration file, define the parameters that are specific to a phone such as the lines configured on a phone and the users defined for those lines.

**Before You Begin**

- Review the guidelines and restrictions documented in the “Configuration File Guidelines” section on page 2-4.
- Line parameters (those identified as `linex`) define a line on the phone. If you configure a line to use an e-mail address, that line can only be called using an e-mail address. Similarly, if you configure a line to use a number, that line can only be called using the number. Each line can have a different proxy configured.
- For a complete list of the SIP parameters that you can configure, see the “Modifying the Phone’s SIP Settings” section on page 3-5.

## Procedure

- Step 1** Using an ASCII editor, create a phone-specific configuration file for each phone that you plan to install. In the phone-specific configuration file, define values for the following SIP parameters (where *x* is a number 1 through 6):
- `linex_name`—(Required) Number or e-mail address used when registering. When entering a number, enter the number without any dashes. For example, enter 555-1212 as 5551212. When entering an e-mail address, enter the e-mail ID without the host name.
  - `linex_authname`—(Required when registration is enabled and the proxy server requires authentication) Name used by the phone for authentication if a registration is challenged by the proxy server during initialization. If a value is not configured for the `linex_authname` parameter when registration is enabled, the default name is used. The default name is UNPROVISIONED.
  - `linex_password`—(Required when registration is enabled and the proxy requires authentication) Password used by the phone for authentication if a registration is challenged by the proxy server during initialization. If a value is not configured for the `linex_password` parameter when registration is enabled, the default logical password is used. The default logical password is UNPROVISIONED.
- Step 2** Save the file to your TFTP server (in the root directory or a subdirectory containing all the phone-specific configuration files). Name the file SIPXXXXXXXXXXXX.cnf where XXXXXXXXXXXXXXX is the MAC address of the phone. The MAC address must be in uppercase and the extension, cnf, must be in lowercase (for example, SIP00503EFFF842.cnf).

The following is an example of a configuration file:

```
; phone-specific configuration file sample
; Line 1 phone number
line1_name : 5551212

; Line 1 name for authentication with proxy server
line1_authname : 5551212

; Line 1 authentication name password
line1_password : password
```

## Manually Configuring the SIP Parameters

If you did not configure the SIP parameters via a TFTP server, you must manually configure them after you have connected the phone as described in the “Connecting the Phone” section on page 2-11.

### Before You Begin

- Connect your phone as described in the “Connecting the Phone” section on page 2-11.
- Unlock configuration mode as described in the “Unlocking Configuration Mode” section on page 3-2. By default, the SIP parameters are locked to ensure that end users cannot modify settings that might affect their call capabilities.
- Review the guidelines on using the Cisco SIP IP phone menus documented in the “Using the Cisco SIP IP Phone Menu Interface” section on page 2-15.
- When configuring the Preferred Codec and Out of Band DTMF parameters, press the **Change** soft key until the option you desire is displayed and then press the **Save** soft key.

- After making your changes, relock configuration mode as described in the “Locking Configuration Mode” section on page 3-2.
- For a complete list of the SIP parameters that you can configure, see the “Modifying the Phone’s SIP Settings” section on page 3-5.

### Procedure

- Step 1** Press the **settings** key. The Settings menu is displayed.
- Step 2** Highlight **SIP Configuration**. The SIP Configuration menu is displayed.
- Step 3** Highlight **Line 1 Settings**.
- Step 4** Press the **Select** soft key. The Line 1 Configuration menu is displayed.
- Step 5** Highlight and press the **Select** soft key to configure the parameters shown in Table 2-1:

**Table 2-1 Manual SIP Configuration Parameters**

Parameter	Required or Optional	Description
Name	Required	Number or e-mail address used when registering. When entering a number, enter the number without any dashes. For example, enter 555-1212 as 5551212. When entering an e-mail address, enter the e-mail ID without the host name.
Shortname	Optional	Name or number associated with the <code>linex_name</code> as you want it to display on the phone’s LCD if the <code>linex_name</code> value exceeds the display area. For example, if the <code>linex_name</code> value is the phone number 111-222-333-4444, you can specify 3444 for this parameter to have 3444 display on the LCD instead. Alternately, if the value for the <code>linex_name</code> parameter is the email address “username@company.com,” you can specify the “username” to have just the user name appear on the LCD instead. This parameter is used for display purposes only. If a value is not specified for this parameter, the value in the Name variable is displayed.
Authentication Name	Required when registration is enabled	Name used by the phone for authentication if a registration is challenged by the proxy server during initialization. If a value is not configured for the Authentication Name parameter when registration is enabled, the default name is used. The default name is UNPROVISIONED.
Authentication Password	Required when registration is enabled	Password used by the phone for authentication if a registration is challenged by the proxy server during initialization. If a value is not configured for the Authentication Password parameter when registration is enabled, the default logical password is used. The default password is UNPROVISIONED.

**Table 2-1 Manual SIP Configuration Parameters**

Parameter	Required or Optional	Description
Display Name	Optional	Identification as it should appear for caller-identification purposes. For example, instead of jdoe@company.com displaying on phones that have caller ID, you can specify John Doe in this parameter to have John Doe display on the called party end instead. If a value is not specified for this parameter, the Name value is used.
Proxy Address	Required for the first line configured on the phone	IP address of the primary SIP proxy server that will be used by the phone. Enter this address in IP dotted-decimal notation, or as an FQDN.
Proxy Port	Required for the first line configured on the phone	Port of the primary SIP proxy server that is used by the phone.

**Step 6** Press the **Back** soft key to exit the Line 1 Configuration menu.

**Step 7** To configure additional lines on the phone, highlight the next **Line x Settings**, press the Select soft key, and repeat Step 5 and Step 6.

**Step 8** When done, press the **Save** soft key to save your changes and exit the SIP Configuration menu.

**Caution**

When you have completed your changes, ensure that you lock the phone as described in the “Locking Configuration Mode” section on page 3-2.

## Configuring Network Parameters

**Note**

This section describes how to configure the basic network parameters that are required for the phone to operate on the network. For a complete list of the network parameters that you can configure, see the “Modifying the Phone’s Network Settings” section on page 3-2.

The network parameters include those parameters that must be configured on a phone for the phone to operate in an IP network. You can configure the required network parameters via DHCP or manually configure them after you have connected the phone to a power supply.

The following parameters must be defined for your phone to establish network connectivity:

- Phone's IP address
- Subnet mask
- Default gateway for the subnet (use “0.0.0.0” if not required)
- Domain name
- DNS server IP address (use “0.0.0.0” if not required)
- TFTP server IP address

When configuring the network parameters of an IP phone, adhere to the following guidelines:

- Use 0.0.0.0 for unused IP addresses.
- You can use 0.0.0.0 for the subnet mask only if the default gateway is also 0.0.0.0.
- The TFTP server must have a nonzero IP address.
- The default gateway must be on the same subnet as the phone.
- The default gateway can be 0.0.0.0 only if the TFTP or DNS server is on the same subnet as the phone.

**Note**

By default, DHCP is enabled on your phone. Before you can manually configure the network parameters, you must disable DHCP after connecting your phone to a power supply.

## Configuring Network Parameters via a DHCP Server

If you are using DHCP to configure the network parameters, configure the following DHCP options on your DHCP server before you connect your Cisco SIP IP phone:

- dhcp option #50 (IP address)
- dhcp option #1 (IP subnet mask)
- dhcp option #3 (Default IP gateway)
- dhcp option #15 (Domain name)
- dhcp option #6 (DNS server IP address)
- dhcp option #66 (TFTP server IP address)

## Manually Configuring the Network Parameters

If you are not using DHCP to configure your network parameters, you must manually configure them.

### Before You Begin

- Connect your phone as described in the “Connecting the Phone” section on page 2-11.
- Unlock configuration mode as described in the “Unlocking Configuration Mode” section on page 3-2. By default, the network parameters are locked to ensure that end users cannot modify settings that might affect their network connectivity.
- Review the guidelines on using the Cisco SIP IP phone menus documented in the “Using the Cisco SIP IP Phone Menu Interface” section on page 2-15.
- When configuring a domain name:
  - Press the **Number** soft key to enter a numerical ID or press the **Alpha** soft key to enter a name.
  - If entering letters, use the numbers on the dial pad associated with a particular letter. For example, the 2 key has the letters A, B, and C. For a lowercase *a*, press the 2 key once. To scroll through the available letters and numbers, press the key repeatedly.
  - Press the << soft key to delete any mistakes.



- After making your changes, relock configuration mode as described in the “Locking Configuration Mode” section on page 3-2.
- For a complete list of the SIP parameters that you can configure, see the “Modifying the Phone’s Network Settings” section on page 3-2.

### Procedure

- 
- Step 1** Press the **settings** key. The Settings menu is displayed.
- Step 2** Highlight **Network Configuration**.
- Step 3** Press the **Select** soft key. The Network Configuration menu is displayed.
- Step 4** Highlight **DHCP Enabled**.
- Step 5** Press the **No** soft key. DHCP is now disabled.
- Step 6** Highlight and configure each of the following parameters:
- IP Address—IP address of the phone.
  - Subnet Mask—IP subnet mask used by the phone.
  - TFTP Server—IP address of the TFTP server from which the phone downloads its configuration files and firmware images.
  - Default routers 1 through 5—IP address of the default gateway used by the phone. Default routers 2 through 5 are the IP addresses of the gateways that the phone attempts to use as an alternate gateway if the primary gateway is not available.
  - Domain Name—Name of the DNS domain in which the phone resides.
  - DNS servers 1 through 5—IP address of the DNS server used by the phone to resolve names to IP addresses. The phone attempts to use DNS servers 2 through 5 if DNS server 1 is unavailable.
- Step 7** When done, press the **Save** soft key. The phone programs the new information into Flash memory and resets.
- 



#### Caution

When you have completed your changes, ensure that you lock the phone as described in the “Locking Configuration Mode” section on page 3-2.

---

## Connecting the Phone

You must connect the phone to the network and to a power source before using it.

### Before You Begin

Refer to Figure 2-1 for a graphical overview of the procedures in this section.

Figure 2-1 Cisco SIP IP Phone Cable Connections

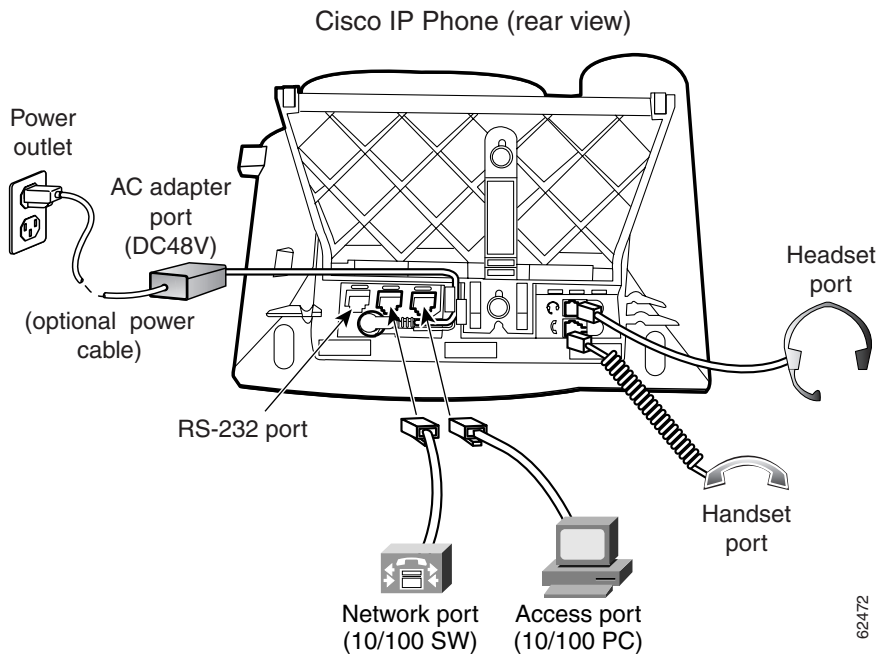

### Procedure

- 
- Step 1** Connect a Category 3 or 5 straight-through Ethernet cable from the switch or hub to the *network* port on the phone.  
See the “Connecting to the Network” section on page 1-11 for more information on the network port.
- Step 2** Connect the handset and headset to their respective ports.  
See the “Using a Headset” section on page 1-12 for more information on the headset port.
- Step 3** Connect a Category 3 or 5 straight-through Ethernet cable from another network device, such as a desktop computer, to the *access* port on the phone (optional).  
See the “Connecting to the Network” section on page 1-11 for more information on the access port.
- Step 4** Connect the power plug to the Cisco AC adapter port (optional).  
See the “Connecting to Power” section on page 1-11 for more information.
- 

## Adjusting the Placement of the Cisco SIP Phone

The Cisco SIP IP phone includes an adjustable footstand. When placing the phone on a desktop surface, you can adjust the tilt height to several different angles in 7.5 degree increments from flat to 60 degrees. Alternatively, you can mount the phone to the wall using the footstand or using the optional locking accessory.

## Adjusting Phone Placement on the Desktop

Adjust the footstand to the height that provides optimum view of the display and use of the buttons and keys.

To adjust the phone placement on the desktop:

- 
- Step 1** Push in the footstand adjustment knob.
- Step 2** Adjust the footstand to its desired height and release the knob.
- 

## Mounting the Phone to the Wall

You can mount the Cisco SIP IP phone on the wall using the footstand as a mounting bracket, or using the optional locking bracket. Use the following procedure to mount the phone on the wall using the standard footstand. To use the optional locking bracket, refer to the *Installing the Wall Mount Kit for the Cisco IP Phone* document.

### Before You Begin

Mounting the Cisco SIP IP phone on the wall requires some tools and equipment that are not provided as standard equipment.

Following are the tools and parts required for a typical Cisco SIP IP phone installation:

- Screwdriver
- Screws to secure the Cisco SIP IP phone to the wall

### Procedure

- 
- Step 1** Push in the footstand adjustment knob.
- Step 2** Adjust the footstand so it is flat against the back of the phone.
- Step 3** Modify the handset rest so that the handset remains on the ear-piece rest when the phone is vertically placed.
- a. Remove the handset from the ear-piece rest.
  - b. Locate the tab (handset wall hook) at the base of the ear-piece rest.
  - c. Slide this tab out, rotate it 180 degrees, and reinsert it.
  - d. Place the handset on the ear-piece rest.
- Step 4** Insert two screws into a wall stud, matching them to the two screw holes on the back of the footstand. The keyholes fit standard phone jack mounts.
- Step 5** Hang the phone on the wall.
-

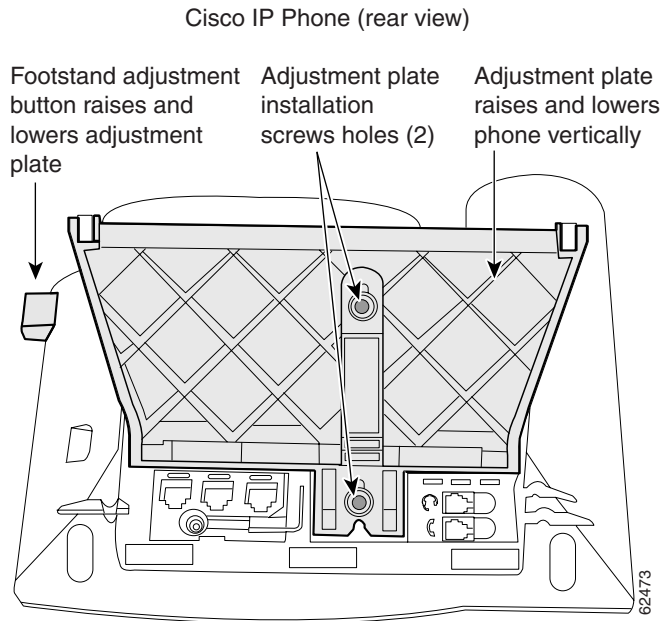
**Figure 2-2 Adjusting the Footstand**

## Verifying Startup

After the phone has power connected to it, the phone begins its startup process by cycling through these steps:

1. These buttons flash on and off in sequence:
  - Headset
  - Mute
  - Speaker
2. The Cisco Systems, Inc. copyright appears on the LCD.
3. These messages appear as phone starts up:
  - Configuring VLAN—The phone is configuring the Ethernet connection.
  - Configuring IP—The phone is contacting the DHCP server to obtain network parameters and the IP address of the TFTP server.
  - Requesting Configuration—The phone is contacting the TFTP server to request its configuration files and compare firmware images.
  - Upgrading Software—The Upgrade Software message displays only if the phone has determined that an image upgrade is required. After upgrading the image, the phone automatically reboots to run the new image.
4. The main LCD screen appears displaying:
  - Primary directory number
  - Soft keys

If the phone successfully passes through these stages, it has started up properly.

## Using the Cisco SIP IP Phone Menu Interface

As you configure your phone's settings via the menu interface, follow these guidelines:

- Select a parameter by pressing the down arrow to scroll to and highlight the parameter or by pressing the number that represents the parameter (located to the left of the parameter on the LCD).
- During configuration, use \* for dots (periods) or press the "." soft key when available on the LCD.
- Press **Cancel** during configuration to cancel all changes and exit a menu.
- When configuring an SIP IP address or ID parameter:
  - Press the **Number** soft key to enter a numerical value or press the **Alpha** soft key to enter a name.
  - Use the buttons on the dial pad to enter a new value.
  - If entering letters, use the numbers on the dial pad associated with a particular letter. For example, the 2 key has the letters A, B, and C. For a lowercase *a*, press the 2 key once. To scroll through the available letters and numbers, press the key repeatedly.
  - Press the << soft key to delete any mistakes.
- When configuring an network IP address or ID parameter:
  - Use the buttons on the dial pad to enter a new value.
  - Press the << soft key to delete any mistakes.
- After editing a parameter, press the **Validate** soft key to save the value that you have entered and exit the Edit panel.

## Reading the Cisco SIP IP Phone Icons

When using the Cisco SIP IP phone, a variety of icons can display on the phone's LCD. Table 2-2 lists and describes each icon that you might see while using the Cisco SIP IP phone.

**Table 2-2 Cisco SIP IP Phone User Interface Icon Meanings**











Icon	Meaning
	The Cisco IP phone that you are using is running SIP.
	The line is configured for E.164 number dialing, and you can enter only numbers when placing the call. The character <i>x</i> displayed to the right of the icon indicates that registration has failed.

Table 2-2 Cisco SIP IP Phone User Interface Icon Meanings (continued)

Icon	Meaning
	<p>The line is configured for E.164 number dialing and is ready for you to place the call. When a line is configured for E.164 number dialing, you can enter only numbers when placing the call.</p> <p>You can change to URL dialing at any time while dialing on a line by pressing the <b>URL</b> soft key.</p> <p>The character <i>x</i> displayed to the right of the icon indicates that registration has failed.</p>
	<p>The line is configured for URL dialing, and you can enter both numbers and letters when placing the call.</p> <p>The character <i>x</i> displayed to the right of the icon indicates that registration has failed.</p>
	<p>The line is configured for URL dialing and is ready for you to place the call. When a line is configured for URL dialing, you can enter both numbers and letters when placing the call.</p> <p>You can change to E.164 number dialing at any time while dialing on a line by pressing the <b>Number</b> soft key.</p> <p>The character <i>x</i> displayed to the right of the icon indicates that registration has failed.</p>
	The Cisco SIP IP phone configuration mode is locked. When the phone is locked, the phone's network or SIP settings cannot be modified.
	The Cisco SIP IP phone configuration mode is unlocked. When the phone is unlocked, the phone's network or SIP settings can be modified.
	A normal two-way call is on hold (call display is blinking).
	A normal two-way call is connected and communicating.
	A three-way call is on hold (call display is blinking).
	A three-way call is connected and communicating.

# Customizing the Cisco SIP IP Phone Ring Types

The Cisco SIP IP phone ships with two ring types: Chirp1 and Chirp2. By default, your ring type options will be those two choices. However, using the RINGLIST.DAT file, you can customize the ring types that are available to the Cisco SIP IP phone users.

- 
- Step 1** Create a pulse code modulation (PCM) file of the desired ring types and store the PCM files in the root directory of your TFTP server. PCM files must contain no header information and must comply with the following format guidelines:
- 8000 Hz sampling rate
  - 8 bits per sample
  - u-law compression
- Step 2** Using an ASCII editor, open the RINGLIST.DAT file and for each of the ring types you are adding, specify the name as you want it to appear on the Ring Type menu, press **Tab**, and then specify the filename of the ring type. For example, the format of a pointer in your RINGLIST.DAT file should appear similar to the following:
- ```
Ring Type 1    ringer1.pcm
```
- Step 3** After defining pointers for each of the ring types you are adding, save your modifications and close the RINGLIST.DAT file.
- 

## Creating Dial Plans

Dial plans enable the Cisco SIP IP phone to support automatic dialing and automatic generation of a secondary dial tone. If a single dial plan is to be used for a system of phones, the dial plan is best specified in the default configuration file. However, you can create multiple dial plans and specify which phones are to use which dial plan by defining the dial\_template parameter in the phone-specific configuration file. If one phone in a system of phones needs to use a different dial plan than the rest, you need to define the differing dial plan by specifying the dial\_template parameter in that phone's phone-specific configuration file.

**Note**

We recommend that you define the dial\_template parameter in the default configuration file for maintenance and control purposes. Specify the dial\_template parameter in a phone-specific configuration file only if that phone needs to use a different dial plan than is being used by the other phones in the same system.

---

When creating a dial plan, remember the following:

- Dial plans must be in an .xml format and be stored on your TFTP server.
- You must specify which dial plan a phone is to use by specifying the path to the dial plan in the dial\_template parameter that you define in either the phone-specific configuration file or the default configuration. We recommend that the dial\_template parameter be defined in the default configuration file unless a specific phone must use a dial plan that differs from the one being used by other phones in the same system.

- <DIALTEMPLATE> indicates the start of a template and </DIALTEMPLATE> indicates the end of a template
- Rules are matched from start to finish with the longest matching rule taken as the one to use. Matches against a period are not counted for the length to be the longest.

**Step 1** Using an ASCII editor, open a new file.

**Step 2** Type <DIALTEMPLATE> to indicate the start of the dial-plan template.

**Step 3** For each of the numbering schemes that you wish to define, add the following string to the template, each starting each on a separate line:

```
<TEMPLATE MATCH="pattern" Timeout="sec" User="type" Rewrite="altstrng" Route="route"
```

Where:

- MATCH= "*pattern*" is the dial pattern to match. When entering the value of *pattern*, use a period (.) to match any character or use an asterisk (\*) to match one or more characters. To have the phone generate a secondary dial tone when the part of the template matches, use a comma (,).
- Timeout= "*sec*" is the number of seconds before a timeout occurs and the number is dialed as entered by the user. To have the number dial immediately, specify 0.
- User= "*type*" is the either IP or Phone. Enter **User=phone** or **User=IP** to have the tag automatically added to the dialed number. This entry is not case sensitive.
- Rewrite= "*xxx*" is the alternate string to be dialed instead of what the user enters.

The rewrite rules are matched from start to finish with the longest matching rule taken as the one to use. Matches against a period are not counted for the length to be the longest. A complete rule is not matched unless it has more nonwildcard matches than an incomplete rule. You can put comments into the file with <!-- to start the comment and --> to terminate it.

The rules allow for substitution of up to five replacement strings as well as picking off replaced digits one at a time. For example, with a match string of

"ab..cd..ef\*" and an input string of "ab12cd34ef5678"

The following replacement strings work, as follows.

REWRITE Output Notes

%s ab12cd34ef5678

%0 ab12cd34ef5678

%1 12

%2 34

%3 56

%4 that is, nothing

%5 that is, nothing

XYZ.... XYZ1234

X.Y.Z... X1Y2Z345

919%1%2%3 919123456

AB...X%1X.. AB123X12X45 (Note how "12" appears twice.)

X%1X%1X%1 X12X12X12 (You can reuse the string.)

X%1%1%1 Xab12cd34ef5678%1%1 (This produces a %.)



919 919 (No need to use the input.)

..... 12345678 (Note that nothing goes in for the extra dots.)

- Route= “route” is default, emergency, or FQDN. FQDN is treated the same as default proxy. Route indicates which proxy the call is to be routed to. This entry is not case sensitive.

- Step 4** If desired, specify `<!--comment-->` at the end of each string, where *comment* defines the type of plan (for example, Long Distance or Corporate Dial Plan).
- Step 5** When completed, enter `</DIALTEMPLATE>` to indicate the end of the dial-plan template.
- Step 6** Give the file a unique name specific to the dial plan it defines, and save the file with an .xml extension to your TFTP server.
- Step 7** If the dial plan applies to a specific phone, add the path to the dial plan (without specifying the file type of .xml) via the `dial_template` parameter in the phone-specific configuration file. If the dial plan applies to a system of phones, add the path to the dial plan via the `dial_template` parameter in the default configuration file. For more information on defining the `dial_template` parameter, see the “Modifying the Phone’s SIP Settings” section on page 3-5.

The following is an example of a North American dial plan:

```
<DIALTEMPLATE>
  <TEMPLATE MATCH="0" Timeout="1" User="Phone"/> <!-- Local operator-->
  <TEMPLATE MATCH="9,011*" Timeout="6" User="Phone"/> <!-- International calls-->
  <TEMPLATE MATCH="9,0" Timeout="2" User="Phone"/> <!-- PSTN Operator-->
  <TEMPLATE MATCH="9,11" Timeout="0" User="Phone" Rewrite="9911"/> <!-- Emergency-->
  <TEMPLATE MATCH="w!" Timeout="1" User="PHONE" Rewrite="9911"/> <!-- 911 when entered in Alpha mode -->
  <TEMPLATE MATCH="9,.11" Timeout="0" User="Phone"/> <!-- Service numbers -->
  <TEMPLATE MATCH="9,101....." Timeout="0" User="Phone"/> <!-- Long Distance      Service-->
  <TEMPLATE MATCH="9,10....." Timeout="0" User="Phone"/> <!-- Long Distance      Service-->
  <TEMPLATE MATCH="9,10*" Timeout="6" User="Phone"/> <!-- Long Distance Service-->
  <TEMPLATE MATCH="9,1....." Timeout="0" User="Phone"/> <!-- Long Distance -->
  <TEMPLATE MATCH="9,....." Timeout="0" User="Phone"/> <!-- Local numbers -->
<TEMPLATE MATCH="*" Timeout="15"/> <!-- Anything else -->
</DIALTEMPLATE>
```





## Managing Cisco SIP IP Phones

---

This chapter provides information on the following:

- Changing Your Configuration, page 3-1
- Modifying the Phone's Network Settings, page 3-2
- Modifying the Phone's SIP Settings, page 3-5
- Setting the Date, Time, and Daylight Saving Time, page 3-31
- Erasing the Locally Defined Settings, page 3-35
- Accessing Status Information, page 3-36
- Upgrading the Cisco SIP IP Phone Firmware, page 3-38

### Changing Your Configuration

You can change your Cisco SIP IP phone configuration by any of the following methods:

- Using your phone's buttons and softkeys. You must first follow the instructions in the "Entering Configuration Mode" section on page 3-2.
- Edit the default and phone-specific configuration files on the TFTP server. See the "Modifying SIP Parameters via a TFTP Server" section on page 3-7.
- Use Telnet or a console to connect to your Cisco SIP IP phone and use the command-line interface (CLI). You will need to know your phone's IP address. Press **Settings**, select **Network Configuration**, and scroll down to IP Address to find this address. The default Telnet password is "cisco." See the "Setting the Date, Time, and Daylight Saving Time" section on page 3-31.



---

**Note** Use the CLI only to debug and troubleshoot your Cisco SIP IP phone.

---

You can change the following parameters:

- Network settings. See the "Modifying the Phone's Network Settings" section on page 3-2.
- SIP settings. See the "Modifying the Phone's SIP Settings" section on page 3-5.
- Date, time, and Daylight Saving Time settings. See the "Setting the Date, Time, and Daylight Saving Time" section on page 3-31

# Modifying the Phone's Network Settings

You can display and configure the network settings of a Cisco SIP IP phone. The network settings include information such as the phone's Dynamic Host Configuration Protocol (DHCP) server, MAC address, IP address, and domain name.

## Entering Configuration Mode

When you access the network configuration information on your Cisco SIP IP phone, you will notice that there is a padlock symbol located in the upper-right corner of your LCD. By default, the network configuration information is locked. Before you can modify any of the network configuration parameters, you must unlock the phone.

## Unlocking Configuration Mode

To unlock the Cisco SIP IP phone, press **\*\*#**.

**Note**

You have activated the configuration mode for your phone. There is no indication that an action has taken place.

If the Network Configuration or SIP Configuration panel is displayed, the lock icon in the upper-right corner of your LCD changes to an unlocked state. If you are located elsewhere in the Cisco SIP IP phone menus, the next time you access the Network Configuration or the SIP Configuration panels, the lock icon will be displayed in an unlocked state.

The unlocked symbol indicates that you can modify the network and SIP configuration settings.

## Locking Configuration Mode

To lock the Cisco SIP IP phone when you are done modifying the settings, press **\*\*#**.

If the Network Configuration or SIP Configuration panel is displayed, the lock icon in the upper-right corner of your LCD changes to a locked state. If you are located elsewhere in the Cisco SIP IP phone menus, the next time you access the Network Configuration or the SIP Configuration panels, the lock icon will be displayed in a locked state.

The unlocked symbol indicates that you can modify the network and SIP configuration settings.

## Changing the Network Settings

**Before You Begin**

When configuring network settings, remember the following:

- Unlock configuration mode as described in the “Unlocking Configuration Mode” section on page 3-2. By default, the network parameters are locked to ensure that end users cannot modify settings that might affect their network connectivity.

- Review the guidelines on using the Cisco SIP IP phone menus documented in the “Using the Cisco SIP IP Phone Menu Interface” section on page 2-15.
- After making your changes, relock configuration mode as described in the “Locking Configuration Mode” section on page 3-2.

**Step 1** Press the **settings** key. The Settings menu is displayed.

**Step 2** Highlight **Network Configuration**.

**Step 3** Press the **Select** soft key. The Network Configuration menu is displayed.

Table 3-1 lists the network parameters available in the Network Configuration menu:

**Table 3-1 Network Configuration Parameters**

Parameter	Can Edit?	Description
Admin. VLAN Id	Yes, but if you have an administrative VLAN assigned on the Catalyst switch, that setting overrides any changes made on the phone.	Unique identifier of the VLAN to which the phone is attached. The value in this field is used only in switched networks that are not Cisco networks.
Alternate TFTP	Yes	Whether to use an alternate TFTP server. This field enables an administrator to specify the remote TFTP server rather than the local one. Possible values for this parameter are Yes and No. The default is No. When Yes is specified, the IP address in the TFTP Address parameter must be changed to the address of the alternate TFTP server.
Default Routers 1 through 5	Yes, but DHCP must be disabled.	IP address of the default gateway used by the phone. Default Routers 2 through 5 are the IP addresses of the gateways that the phone attempts to use as an alternate gateway if the primary gateway is unavailable.
DHCP Address Released	Yes	Whether the IP address of the phone can be released for reuse in the network. When you set this field to Yes, the phone sends a DHCP release message to the DHCP server and goes into a release state. The release state provides enough time to remove the phone from the network before the phone attempts to acquire another IP address from the DHCP server. When moving the phone to a new network segment, you should first release the DHCP address.
DHCP Enabled	Yes	Whether the phone will use DHCP to configure network settings (IP address, subnet mask, domain name, default router list, DNS server list, and TFTP address). Valid values for this field are Yes and No. By default, DHCP is enabled on the phone. To manually configure your IP settings, you must first disable DHCP.
DHCP Server	No	IP address of the DHCP server from which the phone received its IP address and additional network settings.
DNS Servers 1 through 5	Yes, but DHCP must be disabled.	IP address of the DNS server used by the phone to resolve names to IP addresses. The phone attempts to use DNS servers 2 through 5 if DNS server 1 is unavailable.
Domain Name	Yes	Name of the DNS domain in which the phone resides.

Table 3-1 Network Configuration Parameters (continued)

Parameter	Can Edit?	Description
Erase Configuration	Yes	Whether to erase all of the locally defined settings on the phone and reset the values to the defaults. Selecting Yes reenables DHCP. For more information on erasing the local configuration, see the “Erasing the Locally Defined Settings” section on page 3-35.
Host Name	No	Unique host name assigned to the phone. The value in this field is always SIP <i>mac</i> where <i>mac</i> is the MAC address of the phone.
IP Address	Yes, but DHCP must be disabled.	IP address of the phone that either was assigned by DHCP or was locally configured.
MAC Address	No	Factory-assigned unique 48-bit hexadecimal MAC address of the phone.
Network Media Type	Yes	Ethernet port negotiation mode. Valid values are: <ul style="list-style-type: none"> <li>• Auto—Port is auto-negotiated. (This is the default value.)</li> <li>• Full-100—Port is configured to be a full-duplex, 100-MB connection.</li> <li>• Half-100—Port is configured to be a half-duplex, 100-MB connection.</li> <li>• Full-10—Port is configured to be a full-duplex, 10-MB connection.</li> <li>• Half-10—Port is configured to be a half-duplex, 10-MB connection.</li> </ul>
Network Port 2 Device Type	Yes	The device type that is connected to port 2 of the phone. Valid values are: <ul style="list-style-type: none"> <li>• Hub/Switch (default)</li> <li>• PC</li> </ul> <p><b>Note</b> If the value is PC, port 2 can be connected only to a PC. If you are not sure about the connection, use the default value. Using a value of “PC” and connecting port 2 to a switch results in spanning tree loops and network confusion.</p>
Operational VLAN Id	No	Unique identifier of the VLAN of which the phone is a member. This identifier is obtained through Cisco Discovery Protocol (CDP).
Subnet Mask	Yes, but DHCP must be disabled.	IP subnet mask used by the phone. A subnet mask partitions the IP address into a network and a host identifier.
TFTP Server	Yes, but DHCP must be disabled.	IP address of the TFTP server from which the phone downloads its configuration files and firmware images.

- Step 4** When done, press the **Save** soft key. The phone programs the new information into Flash memory and resets.

**Caution**

When you have completed your changes, ensure that you lock the phone as described in the “Locking Configuration Mode” section on page 3-2.

## Modifying the Phone's SIP Settings

You can modify the SIP parameters of a Cisco SIP IP phone.

When modifying SIP parameters, remember the following:

- Parameters defined in the default configuration file override the values stored in Flash memory.
- Parameters defined in the phone-specific configuration file override the values specified in the default configuration file.
- Parameters entered locally are used by the phone until the next reboot if a phone-specific configuration file exists.
- If you choose not to configure the phone via a TFTP server, you must manage the phone locally.

Table 3-2 lists each of the SIP parameters that you can configure. In the Configuration column, the name of a parameter as you would specify it in a configuration file is listed. In the menu column (SIP Configuration, Network Configuration, and Services), the name of the same parameter as it would appear on the user interface is listed. If NA appears for a parameter name in a menu column, it cannot be defined via that menu.

**Table 3-2 SIP Parameters Summary**

Configuration File	SIP Configuration Menu	Network Configuration Menu	Services Menu
anonymous_call_block	NA	NA	Anonymous Call Block
autocomplete	NA	NA	Auto-Complete Numbers
callerid_blocking	NA	NA	Caller ID Block
call_waiting	NA	NA	Call Waiting
cnf_join_enable	NA	NA	NA
dial_template	NA	NA	NA
dnd_control	NA	NA	Do Not Disturb
dst_auto_adjust	NA	NA	NA
dst_offset	NA	NA	NA
dst_start_day	NA	NA	NA
dst_start_day_of_week	NA	NA	NA
dst_start_month	NA	NA	NA

Table 3-2 SIP Parameters Summary (continued)

Configuration File	SIP Configuration Menu	Network Configuration Menu	Services Menu
dst_start_time	NA	NA	NA
dst_start_week_of_month	NA	NA	NA
dst_stop_day	NA	NA	NA
dst_stop_day_of_week	NA	NA	NA
dst_stop_month	NA	NA	NA
dst_stop_time	NA	NA	NA
dst_stop_week_of_month	NA	NA	NA
dtmf_avt_payload	NA	NA	NA
dtmf_db_level	NA	NA	NA
dtmf_inband	NA	NA	NA
dtmf_outofband	Out of Band DTMF	NA	NA
enable_vad	Enable VAD	NA	NA
end_media_port	End Media Port	NA	NA
image_version	NA	NA	NA
linex_authname (line1 to line6)	Authentication Name	NA	NA
linex_displayname (line1 to line6)	Display Name	NA	NA
linex_name (line1 to line6)	Name	NA	NA
linex_password (line1 to line6)	Authentication Password	NA	NA
linex_shortname (line1 to line6)	Shortname	NA	NA
messages_uri	Messages URI	NA	NA
nat_address	NAT WAN Address	NA	NA
nat_enable	NAT Enabled	NA	NA
nat_received_processing	NA	NA	NA
network_media_type	NA	Network Media Type	NA
network_port2_type	NA	Network Port 2 Device Type	NA
outbound_proxy	Outbound Proxy	NA	NA
outbound_proxy_port	Outbound Proxy Port	NA	NA
phone_label	Phone Label	NA	NA
phone_password	NA	NA	NA
phone_prompt	NA	NA	NA
preferred_codec	Preferred Codec	NA	NA
proxy_backup	Backup Proxy	NA	NA
proxy_backup_port	Backup Proxy Port	NA	NA
proxy_emergency	Emergency Proxy	NA	NA
proxy_emergency_port	Emergency Proxy Port	NA	NA



**Table 3-2 SIP Parameters Summary (continued)**

Configuration File	SIP Configuration Menu	Network Configuration Menu	Services Menu
proxy_register	Register with Proxy	NA	NA
proxyN_address (N=1 to 6)	Proxy Address	NA	NA
proxyN_port (N=1 to 6)	Proxy Port	NA	NA
sip_invite_retx	NA	NA	NA
sip_retx	NA	NA	NA
sntp_mode	NA	NA	NA
sntp_server	NA	NA	NA
start_media_port	Start Media Port	NA	NA
sync	NA	NA	NA
tftp_cfg_dir	TFTP Directory	NA	NA
time_format_24hr	NA	NA	Time format 24hr
time_zone	NA	NA	NA
timer_invite_expires	NA	NA	NA
timer_register_expires	Register Expires	NA	NA
timer_t1	NA	NA	NA
timer_t2	NA	NA	NA
tos_media	NA	NA	NA
user_info	NA	NA	NA
voip_control_port	VoIP Control Port	NA	NA

## Modifying SIP Parameters via a TFTP Server

If you have set up your phones to retrieve their SIP parameters via a TFTP server as described in the “Configuring SIP Parameters via a TFTP Server” section on page 2-4, you can also modify your SIP parameters using the configuration files.

As explained in the “Configuring SIP Parameters” section on page 2-3, there are two configuration files that you can use to define the SIP parameters; the default configuration file and the phone-specific configuration file. If used, the default configuration file must be stored in the root directory of your TFTP server. The phone-specific configuration file can be stored in the root directory of the TFTP server or a subdirectory in which phone-specific configuration files are stored.

While it is not required, Cisco recommends that you use the default configuration file to define values for SIP parameters that are common to all phones. Doing so will make controlling and maintaining your network easier. You can then define only those parameters that are specific to a phone in the phone-specific configuration file. Phone-specific parameters should be defined only in a phone-specific configuration file or should be manually configured. Phone-specific parameters should not be defined in the default configuration file.

## Modifying the Default SIP Configuration File

In the default configuration file (SIPDefault.cnf), Cisco recommends that you maintain the SIP parameters that are common to all your phones.

By maintaining these parameters in the default configuration file, you can perform global changes, such as upgrading the image version, without having to modify the phone-specific configuration file for each phone.

### Before You Begin

- Ensure that you have downloaded the SIPDefault.cnf file from Cisco.com to the root directory of your TFTP server.
- Review the guidelines and restrictions documented in the “Configuration File Guidelines” section on page 2-4.



---

**Note**

See the “Setting the Date, Time, and Daylight Saving Time” section on page 3-31 section for more information on those parameters.

---

- 
- Step 1** Using an ASCII editor, open the SIPDefault.cnf file and define or modify values for the SIP parameters shown in Table 3-3, as necessary.

**Table 3-3** Default SIP Configuration File Parameters

Parameter	Required or Optional	Description
anonymous_call_block	Optional	<p>Whether the Anonymous Call Block feature is enabled or disabled by default on the phone. Valid values are:</p> <ul style="list-style-type: none"> <li>• 0—The Anonymous Call Blocking feature is disabled by default, but can be turned on and off via the phone's user interface. When disabled, anonymous calls are received.</li> <li>• 1—The Anonymous Call Blocking feature is enabled by default, but can be turned on and off via the phone's user interface. When enabled, anonymous calls are rejected</li> <li>• 2—The Anonymous Call Blocking feature is disabled permanently and cannot be turned on and off locally via the phone's user interface. If specifying this value, specify this parameter in the phone-specific configuration file.</li> <li>• 3—The Anonymous Call Blocking feature is enabled permanently and cannot be turned on and off locally via the phone's user interface. If specifying this value, specify this parameter in the phone-specific configuration file.</li> </ul> <p>The default value is 0.</p>
autocomplete	Optional	<p>Whether to have numbers automatically completed when dialing. Valid values are 0 (disable auto completion) or 1 (enable auto completion). The default is 1.</p>

Table 3-3 Default SIP Configuration File Parameters (continued)

Parameter	Required or Optional	Description
call_waiting	Optional	<p>Whether the call waiting feature is enabled or disabled by default on the phone. Valid values are:</p> <ul style="list-style-type: none"> <li>• 0—The call waiting feature is disabled by default, but can be turned on and off via the phone's user interface. When disabled, call waiting calls are not received.</li> <li>• 1—The call waiting feature is enabled by default, but can be turned on and off via the phone's user interface. When enabled, call waiting calls are accepted.</li> <li>• 2—The call waiting feature is disabled permanently and cannot be turned on and off locally via the phone's user interface. If specifying this value, specify this parameter in the phone-specific configuration file.</li> <li>• 3—The call waiting feature is enabled permanently and cannot be turned on and off locally via the phone's user interface. If specifying this value, specify this parameter in the phone-specific configuration file.</li> </ul> <p>The default value is 1.</p>

Table 3-3 Default SIP Configuration File Parameters (continued)

Parameter	Required or Optional	Description
callerid_blocking	Optional	<p>Whether the Caller ID Blocking feature is enabled or disabled by default on the phone. When enabled, the phone blocks its number or e-mail address from phones that have caller identification capabilities. Valid values are:</p> <ul style="list-style-type: none"> <li>• 0—The Caller ID Blocking feature is disabled by default, but can be turned on and off via the phone's user interface. When disabled, the caller identification is included in the Request-URI header field.</li> <li>• 1—The Caller ID Blocking feature is enabled by default, but can be turned on and off via the phone's user interface. When enabled, "Anonymous" is included in place of the user identification in the Request-URI header field.</li> <li>• 2—The Caller ID Blocking feature is disabled permanently and cannot be turned on and off locally via the phone's user interface. If specifying this value, specify this parameter in the phone-specific configuration file.</li> <li>• 3—The Caller ID Blocking feature is enabled permanently and cannot be turned on and off locally via the phone's user interface. If specifying this value, specify this parameter in the phone-specific configuration file.</li> </ul> <p>The default value is 0.</p>
cnf_join_enable	Optional	<p>Specifies when the conference bridge hangs up whether or not it should attempt to join the two leaf nodes. Valid values are:</p> <ul style="list-style-type: none"> <li>• 0—Do not join two leaf nodes.</li> <li>• 1—Join two leaf nodes.</li> </ul> <p>The default value is 1, or join two leaf nodes.</p>

Table 3-3 Default SIP Configuration File Parameters (continued)

Parameter	Required or Optional	Description
dnd_control	Optional	<p>Whether the Do Not Disturb feature is enabled or disabled by default on the phone or whether the feature is permanently enabled. When the feature is permanently enabled, a phone is a “call out” phone only. When the Do Not Disturb feature is turned on, the phone blocks all calls placed to the phone and logs those calls in the Missed Calls directory. Valid values are:</p> <ul style="list-style-type: none"> <li>• 0—The Do Not Disturb feature is off by default, but can be turned on and off locally via the phone’s user interface.</li> <li>• 1—The Do Not Disturb feature is on by default, but can be turned on and off locally via the phone’s user interface.</li> <li>• 2—The Do Not Disturb feature is off permanently and cannot be turned on and off locally via the phone’s user interface. If specifying this value, specify this parameter in the phone-specific configuration file.</li> <li>• 3—The Do Not Disturb feature is on permanently and cannot be turned on and off locally via the phone’s user interface. This setting sets the phone to be a “call out” phone only. If specifying this value, specify this parameter in the phone-specific configuration file.</li> </ul> <p>The default value is 0.</p>
dst_auto_adjust	Optional	See the “Setting the Date, Time, and Daylight Saving Time” section on page 3-31 section for more information.
dst_offset		
dst_start_day		
dst_start_day_of_week		
dst_start_month		
dst_start_time		
dst_start_week_of_month		
dst_stop_day		
dst_stop_day_of_week		
dst_stop_month		
dst_stop_time		
dst_stop_week_of_month		
dtmf_avt_payload	Optional	Payload type for Audio/Video Transport (AVT) packets. Possible range is 96 to 127. If the value specified exceeds 127, the phone defaults to 101.

Table 3-3 Default SIP Configuration File Parameters (continued)

Parameter	Required or Optional	Description
dtmf_db_level	Optional	In-band DTMF digit tone level. Valid values are: <ul style="list-style-type: none"> <li>• 1 (6 db below nominal)</li> <li>• 2 (3 db below nominal)</li> <li>• 3 (nominal)</li> <li>• 4 (3 db above nominal)</li> <li>• 5 (6 db above nominal)</li> </ul> The default is 3.
dtmf_inband	Optional	Whether to detect and generate in-band signaling format. Valid values are 1 (generate DTMF digits in-band) and 0 (do not generate DTMF digits in-band). The default is 1.
dtmf_outofband	Optional	Whether to generate the out-of-band signaling (for tone detection on the IP side of a gateway) and if so, when. The Cisco SIP IP phone supports out-of-band signaling via the AVT tone method. Valid values are: <ul style="list-style-type: none"> <li>• none—Do not generate DTMF digits out-of-band.</li> <li>• avt—If requested by the remote side, generate DTMF digits out-of-band (and disable in-band DTMF signaling); otherwise, do not generate DTMF digits out-of-band.</li> <li>• avt_always—Always generate DTMF digits out-of-band. This option disables in-band DTMF signaling.</li> </ul> The default is avt.
enable_vad	Optional	Use 0 to disable VAD and 1 to enable VAD. Default is 0.
end_media_port	Optional	The end Real-Time Transport Protocol (RTP) range for media. Default is 32,766. Valid values are 16,384 to 32,766.
image_version	Required	Firmware version that the Cisco SIP IP phone should run. Enter the name of the image version (as it is released by Cisco). Do not enter the extension. You cannot change the image version by changing the file name, because the version is also built into the file header. Trying to change the image version by changing the file name causes the firmware to fail when it compares the version in the header against the file name.
messages_uri	Optional	Number to call to check voice mail. This number is called when the <b>Messages</b> key is pressed.
nat_address	Optional	The WAN IP address of the Network Address Translation (NAT) or firewall server. You can use either a dotted IP address or a DNS name (A record only).

Table 3-3 Default SIP Configuration File Parameters (continued)

Parameter	Required or Optional	Description
nat_enable	Optional	<p>Use 0 to disable NAT and 1 to enable NAT. Default is 0. When NAT is enabled, the Contact header appears like this:</p> <pre>Contact: sip:lineN_name@nat_address:voip_control_port</pre> <p>If nat_address is invalid or UNPROVISIONED, then the Contact header appears like this:</p> <pre>Contact: sip:lineN_name@phone_ip_address:voip_control_port</pre> <p>and the Via header appears like this:</p> <pre>Via: SIP/2.0/UDP phone_ip_address:voip_control_port</pre> <p>If NAT is enabled, the Session Description Protocol (SDP) message uses the nat_address and an RTP port between the start_media_port and the end_media_port range in the C and M fields. All RTP traffic is sourced from the port advertised in the SDP.</p>
nat_received_processing	Optional	<p>Use 0 to disable NAT received processing and 1 to enable NAT received processing. Default is 0.</p> <p>If nat_received_processing is enabled, and received= tag is in the Via header of the 200 OK response from a REGISTER, the IP address in the received= tag is used instead of the nat_address in the Contact header. If this switch occurs, the phone unregisters the old IP address and reregisters with the new IP address.</p>
network_media_type	Optional	<p>Ethernet port negotiation mode. Valid values are:</p> <ul style="list-style-type: none"> <li>• Auto—Port is auto-negotiated.</li> <li>• Full100—Port is configured to be a full-duplex, 100-MB connection.</li> <li>• Half100—Port is configured to be a half-duplex, 100-MB connection.</li> <li>• Full10—Port is configured to be a full-duplex, 10-MB connection.</li> <li>• Half10—Port is configured to be a half-duplex, 10-MB connection.</li> </ul> <p>The default is Auto.</p>



Table 3-3 Default SIP Configuration File Parameters (continued)

Parameter	Required or Optional	Description
network_port2_type	Optional	The device type that is connected to port 2 of the phone. Valid values are: <ul style="list-style-type: none"> <li>• Hub/Switch (default)</li> <li>• PC</li> </ul> <p><b>Note</b> If the value is PC, port 2 can be connected only to a PC. If you are not sure about the connection, use the default value. Using a value of “PC” and connecting port 2 to a switch results in spanning tree loops and network confusion.</p>
outbound_proxy	Optional	The IP address of the outbound proxy server. You can use either a dotted IP address or a DNS name.
outbound_proxy_port	Optional	The port number of the outbound proxy server. The default is 5060. When outbound proxy is enabled, all SIP requests are sent to the outbound proxy server instead of the proxyN_address. All responses continue to follow the using the normal Via processing rules. The media stream is not routed through the outbound proxy. <p>NAT and outbound proxy modes can be independently enabled or disabled. The received= tag is added to the Via header of all responses if there is no received= tag in the uppermost Via header and if the source IP address is different from the IP address in the uppermost Via header. Responses are sent back to the source under the following conditions:</p> <ul style="list-style-type: none"> <li>• If a received= tag is in the uppermost Via header, the response is sent back to the IP address contained in the received= tag.</li> <li>• If there is no received= tag and the IP address in the uppermost Via header is different than the source IP address, the response is sent back to the source IP. Otherwise, the response is sent back to the IP address in the uppermost Via header.</li> </ul>
phone_password	Optional	Password to be used for console or Telnet access. The default password is “cisco.”
phone_prompt	Optional	Prompt to be displayed when using Telnet or console access. The default phone prompt is “SIP Phone.”
preferred_codec	Optional	Codec to use when initiating a call. Valid values are g711alaw, g711ulaw, and g729a. The default is g711ulaw.
proxy_backup	Optional	IP address of the backup proxy server or gateway. Enter this address in IP dotted-decimal notation.
proxy_backup_port	Optional	Port number of the backup proxy server. Default is 5060.

Table 3-3 Default SIP Configuration File Parameters (continued)

Parameter	Required or Optional	Description
proxy_emergency	Optional	IP address of the emergency proxy server or gateway. Enter this address in IP dotted-decimal notation.
proxy_emergency_port	Optional	Port number of the emergency proxy server. Default is 5060.
proxy_register	Optional	<p>Whether the phone must register with a proxy server during initialization. Valid values are 0 and 1. Specify 0 to disable registration during initialization. Specify 1 to enable registration during initialization. The default is 0.</p> <p>After a phone has initialized and registered with a proxy server, changing the value of this parameter to 0 unregisters the phone from the proxy server. To reinitiate a registration, change the value of this parameter back to 1.</p> <p><b>Note</b> If you enable registration, and authentication is required, you must specify values for the <code>linex_authname</code> and <code>linex_password</code> parameters (where <code>x</code> is a number 1 through 6) in the phone-specific configuration file. For information on configuring the phone-specific configuration file, see the “Modifying the Phone-Specific SIP Configuration File” section on page 3-19.</p>
proxy1_address	Required	IP address of the primary SIP proxy server that will be used by the phones. Enter this address in IP dotted-decimal notation.
proxy1_port	Optional	<p>Port number of the primary SIP proxy server. This is the port on which the SIP client listens for messages. The default is 5060.</p> <p><b>Note</b> For additional phone lines, <code>proxyN_address</code> and <code>proxyN_port</code> parameters can be used to assign different proxy addresses to different phone lines. “N” in the parameters represents a phone line. The value of “N” can be from 2 to 6. If the value of “N” is not specified in the <code>proxyN_address</code> parameter, the phone uses the <code>proxy1_address</code> parameter as the default.</p>
proxyN_address	Optional	IP address or DNS name of SIP proxy server that will be used by phone lines other than line 1. For IP address, use the IP dotted-decimal notation. If the <code>proxyN_address</code> parameter is provisioned with an FQDN, the phone sends REGISTER and INVITE messages by using the FQDN in the Req-URI, To, and From fields. If you want to use a dotted IP address, the <code>proxyN_address</code> parameters should be configured as dotted IP addresses.

Table 3-3 Default SIP Configuration File Parameters (continued)

Parameter	Required or Optional	Description
proxyN_port	Optional	Port number of the SIP proxy server that will be used by phone lines other than line 1.
sip_invite_retx	Optional	Maximum number of times an INVITE request will be retransmitted. The valid value is any positive integer. The default is 6.
sip_retx	Optional	Maximum number of times a SIP message other than an INVITE request will be retransmitted. The valid value is any positive integer. The default is 10.
sntp_mode	Optional	See the “Setting the Date, Time, and Daylight Saving Time” section on page 3-31 section for more information.
sntp_server		
start_media_port	Optional	The start RTP range for media. Default is 16,384. Valid values are 16,384 to 32,766.
sync	Optional	Value against which to compare the value in the syncinfo.xml file before performing a remote reboot. Valid value is a character string up to 32 characters long.
tftp_cfg_dir	Required if phone-specific configuration files are located in a subdirectory.	Path to the TFTP subdirectory in which phone-specific configuration files are stored.
time_format_24hr	Optional	Whether a 12- or 24-hour time format is displayed by default on the phones' user interface. Valid values are: <ul style="list-style-type: none"> <li>• 0—The 12-hour format is displayed by default but can be changed to a 24-hour format via the phone's user interface.</li> <li>• 1—The 24-hour format is displayed by default but can be changed to a 12-hour format via the phone's user interface.</li> <li>• 2—The 12-hour format is displayed and cannot be changed to a 24-hour format via the phone's user interface.</li> <li>• 3—The 24-hour format is displayed and cannot be changed to a 12-hour format via the phone's user interface.</li> </ul> The default value is 1.
time_zone	Optional	See the “Setting the Date, Time, and Daylight Saving Time” section on page 3-31 section for more information.
timer_invite_expires	Optional	The amount of time, in seconds, after which a SIP INVITE expires. This value is used in the Expire header field. The valid value is any positive number; however, Cisco recommends 180 seconds. The default is 180.

Table 3-3 Default SIP Configuration File Parameters (continued)

Parameter	Required or Optional	Description
timer_register_expires	Optional	The amount of time, in seconds, after which a REGISTRATION request expires. This value is inserted into the Expire header field. The valid value is any positive number; however, Cisco recommends 3600 seconds. The default is 3600.
timer_t1	Optional	Lowest value (in milliseconds) of the retransmission timer for SIP messages. The valid value is any positive integer. The default is 500.
timer_t2	Optional	Highest value (in milliseconds) of the retransmission timer for SIP messages. The valid value is any positive integer greater than timer_t1. The default is 4000.
tos_media	Optional	Type of service (ToS) level for the media stream being used. Valid values are: <ul style="list-style-type: none"> <li>• 0 (IP_ROUTINE)</li> <li>• 1 (IP_PRIORITY)</li> <li>• 2 (IP_IMMEDIATE)</li> <li>• 3 (IP_FLASH)</li> <li>• 4 (IP_OVERRIDE)</li> <li>• 5 (IP_CRITIC)</li> </ul> The default is 5.
user_info	Optional	Configures the “user=” parameter in the REGISTER message. Valid values are: <ul style="list-style-type: none"> <li>• none—No value is inserted.</li> <li>• phone—The value user=phone is inserted in the To, From, and Contact Headers for REGISTER.</li> <li>• ip—The value user=ip is inserted in the To, From, and Contact Headers for REGISTER.</li> </ul> The default value is none.
voip_control_port	Optional	The UDP port used for SIP messages. Default is 5060. All SIP REQUESTS use voip_control_port as the UDP source port when nat_enable = 1. Valid values are 1025 to 65,535.

**Step 2** Save the file with the same file name, SIPDefault.cnf, to the root directory of your TFTP server.

The following is a sample SIP default configuration file:

```
; sip default configuration file

#Image Version
image_version:POS3-xx-y-zz ;

#Default Codec
preferred_codec :g711ulaw

#Enable Registration
proxy_register :1 ;

#Registration expiration
timer_register_expires :3600 ;

#Proxy address
proxy1_address: 192.168.1.1 ;
```

## Modifying the Phone-Specific SIP Configuration File

In the phone-specific SIP configuration file, maintain those parameters that are specific to a phone such as the lines configured on a phone and the users defined for those lines.

### Before You Begin

- Review the guidelines and restrictions documented in the “Configuration File Guidelines” section on page 2-4.
- Line parameters (those identified as *linex*) define a line on the phone. If you configure a line to use an e-mail address, that line can be called only by using an e-mail address. Similarly, if you configure a line to use a number, that line can be called only by using the number. Each line can have a different proxy configured.

---

**Step 1** Using an ASCII editor, create a phone-specific configuration file for each phone that you plan to install. In the phone-specific configuration file, define values for SIP parameters shown in Table 3-4.



**Note**

---

For all variables, *x* is a number 1 through 6.

---

**Table 3-4 Phone-Specific Configuration Parameters**

Parameter	Required or Optional	Description
linex_name	Required	Number or e-mail address used when registering. When entering a number, enter the number without any dashes. For example, enter 555-1212 as 5551212. When entering an e-mail address, enter the e-mail ID without the host name.
linex_shortcode	Optional	Name or number associated with the linex_name as you want it to display on the phone's LCD if the linex_name length exceeds the allowable space in the display area. For example, if the linex_name value is the phone number 111-222-333-4444, you can specify 34444 for this parameter to have 34444 display on the LCD instead. Alternatively, if the value for the linex_name parameter is the e-mail address "username@company.com", you can specify the "username" to have just the user name appear on the LCD instead.  This parameter is used for display only. If a value is not specified for this parameter, the value in the linex_name variable is displayed.
linex_authname	Required for line 1 when registration is enabled and the proxy server requires authentication	Name used by the phone for authentication if a registration is challenged by the proxy server during initialization. If a value is not configured for the linex_authname parameter for a line when registration is enabled, the value defined for line 1 is used. If a value is not defined for line 1, the default line1_authname is UNPROVISIONED.
linex_password	Required for line 1 when registration is enabled and the proxy server requires authentication	Password used by the phone for authentication if a registration is challenged by the proxy server during initialization. If a value is not configured for the linex_password parameter for a line when registration is enabled, the value defined for line 1 is used. If a value is not defined for line 1, the default line1_password is UNPROVISIONED.
linex_displayname	Optional	Identification as it should appear for caller identification purposes. For example, instead of jdoe@company.com appearing on phones that have caller ID, you can specify John Doe in this parameter to have John Doe appear on the callee end instead. If a value is not specified for this parameter, nothing is used.

Table 3-4 Phone-Specific Configuration Parameters

Parameter	Required or Optional	Description
dnd_control	Optional	<p>Whether the Do Not Disturb feature is enabled or disabled by default on the phone or whether the feature is permanently enabled, making the phone a “call out” phone only. When the Do Not Disturb feature is turned on, the phone blocks all calls placed to the phone and logs those calls in the Missed Calls directory. Valid values are:</p> <ul style="list-style-type: none"> <li>• 0—The Do Not Disturb feature is off by default, but can be turned on and off locally via the phone’s user interface.</li> <li>• 1—The Do Not Disturb feature is on by default, but can be turned on and off locally via the phone’s user interface.</li> <li>• 2—The Do Not Disturb feature is off permanently and cannot be turned on and off locally via the phone’s user interface. If specifying this value, specify this parameter in the phone-specific configuration file.</li> <li>• 3—The Do Not Disturb feature is on permanently and cannot be turned on and off locally via the phone’s user interface. This setting sets the phone to be a “call out” phone only. If specifying this value, specify this parameter in the phone-specific configuration file.</li> </ul> <p><b>Note</b> This parameter is best configured in the SIPDefault.dnf file unless configuring a phone to be a “call-out” phone only. When configuring a phone to be a “call-out” phone, define this parameter in the phone-specific configuration file.</p>
phone_label	Optional	<p>Label to display on the top status line of the LCD. This field is for end-user display only. For example, a phone’s label can display “John Doe’s phone.” Up to 11 characters can be used when specifying the phone label. Save the file to your TFTP server (in the root directory or a subdirectory containing all the phone-specific configuration files). Name the file SIPXXXXYYYYZZZZ.cnf where XXXXYYYYZZZZ is the MAC address of the phone. The MAC address must be in uppercase and the extension, cnf, must be in lower case (for example, SIP00503EFFD842.cnf).</p>

The following is a sample configuration file:

```
; phone-specific configuration file sample
; Line 1 phone number
line1_name : 5551212

; Line 1 name for authentication with proxy server
line1_authname : 5551212

; Line 1 authentication name password
line1_password : password
```

## Modifying the SIP Parameters Directly on Your Phone

If you did not configure the SIP parameters via a TFTP server, you can configure them directly on your phone after you have connected the phone.

### Before You Begin

- Unlock configuration mode as described in the “Unlocking Configuration Mode” section on page 3-2. By default, the SIP parameters are locked to ensure that end users cannot modify settings that might affect their call capabilities.
- Review the guidelines on using the Cisco SIP IP phone menus documented in the “Using the Cisco SIP IP Phone Menu Interface” section on page 2-15.
- Line parameters (those identified as `linex`) define a line on the phone. If you configure a line to use an e-mail address, that line can be called only by using an e-mail address. Similarly, if you configure a line to use a number, that line can be called only by using the number.
- When configuring the Preferred Codec and Out of Band DTMF parameters, press the **Change** soft key until the option you desire is displayed and then press the **Save** soft key.
- After making your changes, relock configuration mode as described in the “Locking Configuration Mode” section on page 3-2.

- 
- Step 1** Press the **settings** key. The Settings menu appears.
- Step 2** Highlight **SIP Configuration**. The SIP Configuration menu appears.
- Step 3** Highlight **Line 1 Settings**.
- Step 4** Press the **Select** soft key. The Line 1 Configuration menu appears.
- Step 5** Highlight and press the **Select** soft key to configure the parameters shown in Table 3-5, as necessary:

**Table 3-5 SIP Configuration Parameters**

Parameter	Required or Optional	
Name	Required	Number or e-mail address used when registering. When entering a number, enter the number without any dashes. For example, enter 555-1212 as 5551212. When entering an e-mail address, enter the e-mail ID without the host name.
Short Name	Optional	Name or number associated with the <code>linex_name</code> as you want it to display on the phone's LCD if the <code>linex_name</code> value exceeds the display area. For example, if the <code>linex_name</code> value is the phone number 111-222-333-4444, you can specify 3444 for this parameter to have 3444 display on the LCD instead. Alternatively, if the value for the <code>linex_name</code> parameter is the e-mail address “username@company.com”, you can specify the “username” to have just the user name appear on the LCD instead. This parameter is used for display only. If a value is not specified for this parameter, the value in the Name variable is displayed.
Authentication Name	Required when registration is enabled	Name used by the phone for authentication if a registration is challenged by the proxy server during initialization.



Table 3-5 SIP Configuration Parameters (continued)

Parameter	Required or Optional	
Authentication Password	Required when registration is enabled	Password used by the phone for authentication if a registration is challenged by the proxy server during initialization. If a value is not configured for the Authentication Password parameter when registration is enabled, the default logical password is used. The default logical password is <i>SIPmacaddress</i> , where <i>macaddress</i> is the MAC address of the phone.
Display Name	Optional	Identification as it should appear for caller identification. For example, instead of <i>jdoe@company.com</i> appearing on phones that have caller ID, you can specify John Doe in this parameter to have John Doe appear on the callee end instead. If a value is not specified for this parameter, the Name value is used.
Proxy Address	Required	IP address of the primary SIP proxy server that will be used by the phone. Enter this address in IP dotted-decimal notation.
Proxy Port	Optional	Port number of the primary SIP proxy server. This is the port that the SIP client will use. The default is 5060.

- Step 6** Press the **Back** soft key to exit the Line 1 Configuration menu.
- Step 7** To configure additional lines on the phone, highlight the next **Line x Settings**, press the **Select** soft key and repeat Step 5 and Step 6, and then continue with Step 8.
- Step 8** In addition to the line settings, you can highlight and press **Select** to configure the parameters on the SIP Configuration menu shown in Table 3-6:

Table 3-6 Additional SIP Configuration Parameters

Parameter	Required or Optional	
Messages URI	Optional	Number to call to check voice mail. This number is called when the <b>Messages</b> key is pressed.
Preferred Codec	Optional	Codec to use when initiating a call. Valid values are g711alaw, g711ulaw, and g729a. The default is g711ulaw.
Out of Band DTMF	Optional	Whether to detect and generate the out-of-band signaling (for tone detection on the IP side of a gateway) and if so, when. The Cisco SIP IP phone supports out-of-bound signaling via the AVT tone method. Valid values are: <ul style="list-style-type: none"> <li>• none—Do not generate DTMF digits out-of-band.</li> <li>• avt—If requested by the remote side, generate DTMF digits out-of-band (and disable in-band DTMF signaling); otherwise, do not generate DTMF digits out-of-band.</li> <li>• avt_always—Always generate DTMF digits out-of-band. This option disables in-band DTMF signaling.</li> </ul> The default is avt.
Register with Proxy	Optional	Whether the phone must register with a proxy server during initialization. Valid values are Yes and No. Select the <b>No</b> soft key to disable registration during initialization. Select the <b>Yes</b> soft key to enable registration during initialization. The default is No. After a phone has initialized and registered with a proxy server, changing the value of this parameter to No unregisters the phone from the proxy server. To reinitiate a registration, change the value of this parameter back to Yes. <p><b>Note</b> If you enable registration, and authentication is required, you must specify values for the Authentication Name and Authentication Password parameters.</p>
Register Expires	Optional	The amount of time, in seconds, after which a REGISTRATION request expires. This value is used the Expire header field. The valid value is any positive number; however, Cisco recommends 3600 seconds. The default is 3600.
TFTP Directory	Required if phone-specific configuration files are located in a subdirectory	Path to the TFTP subdirectory in which phone-specific configuration files are stored.
Phone Label	Optional	Label to display on the top status line of the LCD. This field is for end-user display only. For example, a phone's label can display "John Doe's phone." Up to 11 characters can be used when specifying the phone label.
Enable VAD	Optional	Specifies whether VAD is enabled or disabled.
VoIP Control Port	Optional	The UDP port used for SIP messages. Default is 5060. All SIP REQUESTS use voip_control_port as the UDP source port when nat_enable = 1. Valid values are 1025 to 65535.

**Table 3-6** Additional SIP Configuration Parameters (continued)

Parameter	Required or Optional	
Start Media Port	Optional	The start RTP range for media. Default is 16,384. Valid values are 16,384 to 32,766.
End Media Port	Optional	The end RTP range for media. Default is 32,766. Valid values are 16,384 to 32,766.
Backup Proxy	Optional	IP address of the backup proxy server or gateway. Enter this address in IP dotted-decimal notation.
Backup Proxy Port	Optional	Port number of the backup proxy server. Default is 5060.
Emergency Proxy	Optional	IP address of the emergency proxy server or gateway. Enter this address in IP dotted-decimal notation.
Emergency Proxy Port	Optional	Port number of the emergency proxy. Default is 5060.
Outbound Proxy	Optional	The IP address of the outbound proxy server. You can use either a dotted IP address or a DNS name (A record only).
Outbound Proxy Port	Optional	The port number of the outbound proxy server. The default is 5060.
NAT Enabled	Optional	Choose No to disable NAT and Yes to enable NAT.
NAT Address	Optional	The WAN IP address of the NAT or firewall server. You can use either a dotted IP address or a DNS name (A record only).

**Step 9** When done, press the **Save** soft key to save your changes and exit the SIP Configuration menu.

**Caution**

When you have completed your changes, ensure that you lock the phone as described in the “Locking Configuration Mode” section on page 3-2.

## Using the Command-Line Interface

You can use Telnet or a console to connect to your Cisco SIP IP phone to debug or troubleshoot the phone. Table 3-7 shows the available CLI commands:

Table 3-7 CLI Commands

Command	Purpose
<pre>SIP Phone&gt; debug {console-stall   strlib   malloc   malloc-table   sk-platform   flash   dsp   vcm   dtmf   task-socket   lsm   fsm   auth   fim   gsm   cc   cc-msg   softkeys   error   sip-task   sip-state   sip-messages   sip-reg-state   dns   config   sntp   sntp-packet}</pre>	<p>Shows detailed debug output when used with the following keywords:</p> <ul style="list-style-type: none"> <li>• <b>console-stall</b>: Shows debug output for the console-stall driver output mode.</li> <li>• <b>strlib</b>: Shows debug output for the string library.</li> <li>• <b>malloc</b>: Shows debug output for memory allocation.</li> <li>• <b>malloc-table</b>: Shows debug output for the memory allocation table.</li> <li>• <b>sk-platform</b>: Shows debug output for the platform.</li> <li>• <b>flash</b>: Shows debug output for the Flash memory.</li> <li>• <b>dsp</b>: Shows debug output for DSP accesses.</li> <li>• <b>vcm</b>: Shows debug output for the voice channel manager (VCM), including tones, ringing, and volume.</li> <li>• <b>dtmf</b>: Shows debug output for DTMF relay.</li> <li>• <b>task-socket</b>: Shows socket task debug output.</li> <li>• <b>lsm</b>: Shows debug output for the Line State Manager.</li> <li>• <b>fsm</b>: Shows debug output for the Feature State Manager.</li> <li>• <b>auth</b>: Shows debug output for the SIP authorization state machine.</li> <li>• <b>fim</b>: Shows debug output for the Feature Interaction Manager.</li> <li>• <b>gsm</b>: Shows debug output for the Global State Manager.</li> <li>• <b>cc</b>: Shows debug output for call control.</li> <li>• <b>cc-msg</b>: Shows debug output for the call control messages.</li> <li>• <b>softkeys</b>: Displays the currently available soft key sets.</li> <li>• <b>error</b>: Shows general error debug output.</li> <li>• <b>sip-task</b>: Shows debug output for the SIP task.</li> <li>• <b>sip-state</b>: Shows debug output for the SIP state machine.</li> <li>• <b>sip-messages</b>: Shows debug output for SIP messaging.</li> <li>• <b>sip-reg-state</b>: Shows debug output for the SIP registration state machine.</li> <li>• <b>dns</b>: Shows the DNS command-line interface (CLI) configuration; allows you to clear the cache and set servers).</li> </ul>

Table 3-7 CLI Commands (continued)

Command	Purpose
debug command keywords (continued)	<ul style="list-style-type: none"> <li>• <b>config</b>: Shows output for the <b>config system</b> command.</li> <li>• <b>sntp</b>: Shows debug output for Simple Network Time Protocol (SNTP).</li> <li>• <b>sntp-packet</b>: Displays full SNTP packet data.</li> </ul> <p><b>Note</b> Do not use the <b>debug all</b> command, because it can cause the phone to become inoperable. This command is for use only by Cisco TAC personnel.</p>
SIP Phone> <b>dns</b>	<p>Manipulates the DNS system. The following arguments are used:</p> <ul style="list-style-type: none"> <li>• <b>-p</b>: Prints out the DNS cache table.</li> <li>• <b>-c</b>: Clears out the DNS cache table.</li> <li>• <b>-s ipaddress</b>: Sets the primary DNS server.</li> <li>• <b>-b ip address</b>: Sets the first backup server.</li> </ul>
SIP Phone> <b>exit</b>	Exits the Telnet or console session.
SIP Phone> <b>ping</b> <i>ipaddress number packetsize timeout</i>	Sends an Internet Control Message Protocol (ICMP) ping to a network address. You can use a dotted IP address or an alphanumeric address. The <i>number</i> value specifies how many pings to send; the default value is 5. The <i>packetsize</i> argument defines the size of the packet; you can send any size packet up to 1480 bytes and the default packet size is 100. The <i>timeout</i> value is measured in seconds and identifies how long to wait before the request times out; the default is 2.
SIP Phone> <b>register</b> { <i>option</i>   <i>line</i> }	Instructs the Cisco SIP IP phone to register with the proxy server. Option values are 0 and 1; 0 is unregister and 1 is register. These values are set for each line.
SIP Phone> <b>reset</b>	Resets the phone line.

Table 3-7 CLI Commands (continued)

Command	Purpose
<pre>SIP Phone&gt; show {debug   strpool   memorymap   dump   malloctable   stacks   status   abort_vector   flash   dspstate   rtp   tcp   lsm   fsm   fsmdef   fsmcnf   fsmxfr   fim   gsm   register   network   config   personaldir}</pre>	<p>Shows information about the SIP IP phone. The following keywords are used:</p> <ul style="list-style-type: none"> <li>• <b>debug</b>: Shows which debug modes are activated.</li> <li>• <b>strpool</b>: Shows the string library pool of strings.</li> <li>• <b>memorymap</b>: Shows memory mapping table, including free, used, and wasted blocks.</li> <li>• <b>dump</b>: Displays a dump of the memory contents.</li> <li>• <b>malloctable</b>: Shows the memory allocation table.</li> <li>• <b>stacks</b>: Shows tasks and buffer lists.</li> <li>• <b>status</b>: Shows the current phone status, including errors.</li> <li>• <b>abort_vector</b>: Shows the address of the last recorded abort vector.</li> <li>• <b>flash</b>: Shows flash memory information.</li> <li>• <b>dspstate</b>: Shows the DSP status, including whether the DSP is ready, the audio mode, if keepalive pending is turned on, and the ringer state.</li> <li>• <b>rtp</b>: Shows packet statistics for the RTP streams.</li> <li>• <b>tcp</b>: Shows the status of TCP ports, including the state (listen or closed) and the port number.</li> <li>• <b>lsm</b>: Shows the current status of the Line Manager control blocks.</li> <li>• <b>fsm</b>: Shows the current status of the Feature State function control blocks.</li> <li>• <b>fsmdef</b>: Shows the current status of the default Feature State Manager data control blocks.</li> <li>• <b>fsmcnf</b>: Shows the current status of the Conference Feature State Manager call control blocks.</li> <li>• <b>fsmxfr</b>: Shows the current status of the Transfer Feature State Manager transfer control blocks.</li> <li>• <b>fim</b>: Shows the current status of the Feature Interaction Manager control blocks (interface control blocks and state control blocks).</li> <li>• <b>gsm</b>: Turns on debugging for vcm, lsm, fim, fsm, and gsm.</li> </ul>

Table 3-7 CLI Commands (continued)

Command	Purpose
show command keywords (continued)	<ul style="list-style-type: none"> <li>• <b>register</b>: Shows the current registration status of SIP lines.</li> <li>• <b>network</b>: Shows network information, such as phone platform, DHCP server, phone IP address and subnet mask, default GW, address of the TFTP server, phone MAC address, domain name, and phone name.</li> <li>• <b>config</b>: Shows the current Flash configuration, including network information, phone label and password, SNTP server address, DST information, time and date format, and input and output port numbers.</li> <li>• <b>personaldir</b>: Displays the current contents of the personal directory.</li> </ul>
<pre>SIP Phone&gt; test {open   close   key   onhook   offhook   show   hide}</pre>	<p>Accesses the remote call test interface, allowing you to control the phone from a remote site. To use this feature, enter the <b>test open</b> command. To prevent use of this feature, enter the <b>test close</b> command.</p> <p>The following commands are available:</p> <ul style="list-style-type: none"> <li>• <b>test key</b>: When a test session is open, you can simulate key presses using the <b>test key k1 k2 k3...k13</b> command, where k1 through k13 represent the following key names: <ul style="list-style-type: none"> <li>- voldn—Volume down</li> <li>- volup—Volume up</li> <li>- headset—Headset</li> <li>- spkr—Speaker</li> <li>- mute—Mute</li> <li>- info—Info</li> <li>- msgs—Messages</li> <li>- serv—Services</li> <li>- dir—Directories</li> <li>- set—Settings</li> <li>- navup—Navigate up</li> <li>- navdn—Navigate down</li> </ul> <p>The keys 0 through 9, #, and * may be entered in continuous strings to better express typical dialing strings. A typical command would be <b>test ky 23234</b>.</p> </li> <li>• <b>test onhook</b>: Simulates a handset onhook event.</li> <li>• <b>test offhook</b>: Simulates a handset offhook event.</li> <li>• <b>test show</b>: Shows test feedback.</li> <li>• <b>test hide</b>: Hides test feedback.</li> </ul>



Table 3-7 CLI Commands (continued)

Command	Purpose
SIP Phone> <b>tty</b> { <b>echo</b> { <b>on</b>   <b>off</b> }   <b>mon</b>   <b>timeout</b> <i>value</i>   <b>kill session</b>   <b>msg</b> }	Controls the Telnet system. The <b>echo</b> keyword controls local echo. The <b>mon</b> keyword sends all debug output to both the console and Telnet sessions. The <b>timeout</b> <i>value</i> keyword sets the Telnet session timeout period based on the value. The <i>value</i> range is 0 through 65,535. The <b>kill session</b> keyword tears down the Telnet session specified by the <i>session</i> argument. The <b>msg</b> keyword allows you to send a message to another terminal logged into the phone; for example, you can send a message telling everyone else that is logged in to log off.
SIP Phone> <b>traceroute</b> <i>ip-address</i> [ <i>ttl</i> ]	Initiates a traceroute session from the console or from a Telnet session. Traceroute shows the route that IP datagrams follow from the SIP IP phone to the specified IP address. Use the following two arguments: <ul style="list-style-type: none"> <li><i>ip-address</i>: The dotted IP address or alphanumeric address (host name) of the host to which you are sending the traceroute.</li> <li><i>ttl</i>: The time-to-live value, or the number of routers (hops) through which the datagram can pass. The default value is 30.</li> </ul>
SIP Phone> <b>undebug</b> { <b>console-stall</b>   <b>strlib</b>   <b>malloc</b>   <b>malloc-table</b>   <b>sk-platform</b>   <b>flash</b>   <b>vcm</b>   <b>dtmf</b>   <b>task-socket</b>   <b>lsm</b>   <b>fsm</b>   <b>auth</b>   <b>fim</b>   <b>gsm</b>   <b>cc</b>   <b>cc-msg</b>   <b>softkeys</b>   <b>error</b>   <b>sip-task</b>   <b>sip-state</b>   <b>sip-messages</b>   <b>sip-reg-state</b>   <b>dns</b>   <b>config</b>   <b>sntp</b>   <b>sntp-packet</b> }	Turns off debugging.

## Setting the Date, Time, and Daylight Saving Time

The current date and time is supported on the Cisco SIP IP phone via SNTP and is displayed on the phone's LCD. In addition to supporting the current date and time, Daylight Saving Time (DST) and time zone settings are also supported. DST can be configured to be obtained via an absolute (for example, starts on April 1 and ends on October 1) or relative (for example, starts the first Sunday in April and ends on the last day of October) configuration.

International time zone abbreviations are supported and are case sensitive (must be in all capital letters).

Cisco recommends that date and time-related parameters be defined in the SIPDefault.cnf file.

### Before You Begin

When configuring the date, time, time zone, and DST settings, remember the following:

- Review the guidelines and restrictions documented in the “Configuration File Guidelines” section on page 2-4.
- Determine whether you want to configure absolute DST or relative DST.
- The SNTP parameters specify how the phone will obtain the current time from an SNTP server. Review the guidelines in Table 3-8 and Table 3-9 before configuring the SNTP parameters.

Table 3-8 lists the actions that take place when a null value (0.0.0.0) is specified in the `sntp_server` parameter.

**Table 3-8 Actions Based on `sntp_mode` When the `sntp_server` Parameter Is Set to a Null Value**

<code>sntp_server</code> =0.0.0.0	<code>sntp_mode</code> = unicast	<code>sntp_mode</code> = multicast	<code>sntp_mode</code> = anycast	<code>sntp mode</code> = directedbroadcast
<b>Sends</b>	Nothing.  No known server with which to communicate.	Nothing.  When in multicast mode, SNTP requests are not sent.	SNTP packet to the local network broadcast address.  After the first SNTP response is received, the phone switches to unicast mode with the server being set as the one who first responded.	SNTP packet to the local network broadcast address.  After the first SNTP response is received, the phone switches to multicast mode.
<b>Receives</b>	Nothing.  No known server with which to communicate.	SNTP data via the SNTP/NTP multicast address from the local network broadcast address from any server on the network.	Unicast SNTP data from the SNTP server that first responded to the network broadcast request.	SNTP data from the SNTP/NTP multicast address and the local network broadcast address from any server on the network.

Table 3-9 lists the actions that take place when a valid IP address is specified in the `sntp_server` parameter.

**Table 3-9 Actions Based on `sntp_mode` When the `sntp_server` Parameter Is Set to an IP Address**

<code>sntp_server</code> = 192.168.1.9	<code>sntp_mode</code> = unicast	<code>sntp_mode</code> = multicast	<code>sntp_mode</code> = anycast	<code>sntp_mode</code> = directedbroadcast
<b>Sends</b>	SNTP request to the SNTP server.	Nothing.  When in multicast mode, SNTP requests are not sent.	SNTP request to the SNTP server.	SNTP packet to the SNTP server.  After the first SNTP response is received, the phone switches to multicast mode.
<b>Receives</b>	SNTP response from the SNTP server and ignores responses from other SNTP servers.	SNTP data via the SNTP/NTP multicast address from the local network broadcast address.	SNTP response from the SNTP server and ignores responses from other SNTP servers.	SNTP data from the SNTP/NTP multicast address and the local network broadcast address and ignores responses from other SNTP servers.

- 
- Step 1** Using an ASCII editor, open the SIPDefault.cnf file and define or modify values for the following SNTP-specific SIP parameters as necessary:
- **sntp\_mode**—(Required) Mode in which the phone listens for the SNTP server. Valid values are unicast, multicast, anycast, or directedbroadcast.  
See Table 3-8 and Table 3-9 for an explanation on how these values work, depending on the **sntp\_server** parameter value.
  - **sntp\_server**—(Required) IP address of the SNTP server from which the phone will obtain time data.  
See Table 3-8 and Table 3-9 for an explanation on how these values work, depending on the **sntp\_server** parameter value.
  - **time\_zone**—(Required) Time zone in which the phone is located. Valid values are hour/minute, -hour/minute, +hour/minute, hour, -hour, +hour, PST, MST, CST, or EST. (Time zone abbreviations are case sensitive and must be in all capital letters.)
- Step 2** To configure common DST settings, specify values for the following parameters:
- **dst\_offset**—Offset from the phone's time when DST is in effect. When DST is over, the specified offset is no longer applied to the phone's time. Valid values are the same as for the **time\_zone** parameter.
  - **dst\_auto\_adjust**—Whether or not DST is automatically adjusted on the phones. Valid values are 0 (disable automatic DST adjustment) or 1 (enable automatic DST adjustment). The default is 1.
  - **dst\_start\_month**—Month in which DST starts. Valid values are January, February, March, April, May, June, July, August, September, October, November, and December or 1 through 12 with January being 1 and December being 12. When specifying the name of a month, the value is not case sensitive. In the United States, the default value is April.
  - **dst\_stop\_month**—Month in which DST ends. Valid values are January, February, March, April, May, June, July, August, September, October, November, and December or 1 through 12 with January being 1 and December being 12. When specifying the name of a month, the value is not case sensitive. In the United States, the default value is October.
  - **dst\_start\_time**—Time of day on which DST begins. Valid values are hour/minute (02/00) or hour (02:00). In the United States, the default value is 02:00.
  - **dst\_stop\_time**—Time of day on which DST ends. Valid values are hour/minute (02/00) or hour (02:00). In the United States, the default value is 02:00.
- Step 3** To configure absolute DST, specify values for the following parameters or to configure relative DST, proceed to Step 4:
- **dst\_start\_day**—Day of the month on which DST begins.  
Valid values are 1 through 31 for the days of the month or 0 when specifying relative DST to specify that this field be ignored and that the value in the **dst\_start\_day\_of\_week** parameter be used instead.
  - **dst\_stop\_day**—Day of the month on which DST ends.  
Valid values are 1 through 31 for the days of the month or 0 when specifying relative DST to specify that this field be ignored and that the value in the **dst\_stop\_day\_of\_week** parameter be used instead.
- Step 4** To configure relative DST, specify values for the following parameters:
- **dst\_start\_day\_of\_week**—Day of the week on which DST begins.  
Valid values are Sunday or Sun, Monday or Mon, Tuesday or Tue, Wednesday or Wed, Thursday or Thu, Friday or Fri, Saturday or Sat, or Sunday or Sun or 1 through 7 with 1 being Sunday and 7 being Saturday. When specifying the name of the day, the value is not case sensitive. In the United States, the default value is Sunday.

- `dst_start_week_of_month`—Week of month in which DST begins.  
Valid values are 1 through 6 and 8, with 1 being the first week and each number thereafter being subsequent weeks and 8 specifying the last week in the month regardless of which week the last week is. In the United States, the default value is 1.
- `dst_stop_day_of_week`—Day of the week on which DST ends.  
Valid values are Sunday or Sun, Monday or Mon, Tuesday or Tue, Wednesday or Wed, Thursday or Thu, Friday or Fri, Saturday or Sat, or Sunday or Sun or 1 through 7, with 1 being Sunday and 7 being Saturday. When specifying the name of the day, the value is not case sensitive. In the United States, the default value is Sunday.
- `dst_stop_week_of_month`—Week of month in which DST ends.  
Valid values are 1 through 6 and 8, with 1 being the first week and each number thereafter being subsequent weeks and 8 specifying the last week in the month regardless of which week the last week is. In the United States, the default value is 8.

**Step 5** Save the file with the same file name, SIPDefault.cnf, to the root directory of your TFTP server.

---

The following is a sample configuration for an absolute DST configuration:

```
; sip default configuration file
(additional configuration text omitted)

time_zone : 03/00
dst_offset : 01/00
dst_start_month : April
dst_start_day : 1
dst_start_time : 02/00
dst_stop_month : October
dst_stop_day : 1
dst_stop_time : 02/00
dst_stop_autoadjust : 1

(additional configuration text omitted)
```

The following is a sample configuration for a relative DST configuration:

```
; sip default configuration file
(additional configuration text omitted)

time_zone : PST
dst_offset : 01/00
dst_start_month : April
dst_start_day : 0
dst_start_day_of_week : Sunday
dst_start_week_of_month : 1
dst_start_time : 02/00
dst_stop_month : October
dst_stop_day : 0
dst_stop_day_of_week : Sunday
dst_stop_week_of_month : 8
dst_stop_time : 02/00
dst_stop_autoadjust : 1

(additional configuration text omitted)
```

# Erasing the Locally Defined Settings

You can erase the locally defined network settings and the SIP settings that have been configured in the phone.

## Erasing the Locally Defined Network Settings

When you erase the locally defined settings, the values are reset to the defaults.

### Before You Begin

- Unlock configuration mode as described in the “Unlocking Configuration Mode” section on page 3-2.
- If DHCP has been disabled on a phone, clearing the phone’s settings reenables it.
- Select the Erase Config parameter by pressing the down arrow to scroll to and highlight the parameter or by pressing the number that represents the parameter (located to the left of the parameter name on the LCD).

- 
- Step 1** Press the **settings** key. The Settings menu appears.
- Step 2** Highlight **Network Configuration**.
- Step 3** Press the **Select** soft key. The Network Configuration settings are displayed.
- Step 4** Highlight **Erase Configuration**.
- Step 5** Press the **Yes** soft key.
- Step 6** Press the **Save** soft key. The phone programs the new information into Flash memory and resets.
- 

## Erasing the Locally Defined SIP Settings

When you erase the locally defined SIP settings, the values are reset to the defaults.



### Note

If your system has been set up to have the phones retrieve their SIP parameters via a TFTP server, you must edit the configuration file in which a parameter is defined to delete the parameter. When deleting a parameter, leave the variable in the file, but change its value to a null value “” or “UNPROVISIONED”. If both the variable and its value are removed, the phone uses the setting for that variable that it has stored in Flash memory.

---

### Before You Begin

Unlock configuration mode as described in the “Unlocking Configuration Mode” section on page 3-2.

- 
- Step 1** Press the **settings** key. The Settings menu appears.
- Step 2** Highlight **SIP Configuration**.
- Step 3** Press the **Select** soft key. The SIP Configuration settings are displayed.
- Step 4** Highlight the parameter for which you want to erase the setting.

- Step 5** Press the **Edit** soft key.
- Step 6** Press the << soft key to delete the current value.
- Step 7** Press the **Validate** soft key to save your change and exit the Edit panel.
- Step 8** If modifying a line parameter, press the **Back** soft key to exit the Line Configuration panel.
- Step 9** Press the **Save** soft key. The phone programs the new information into Flash memory and resets.
- 

## Accessing Status Information

There are several types of status information that you can access via the **settings** key. The information that you can obtain via the **settings** key can aid in system management.

To access status information, select **settings** and then select **Status** from the Settings menu. From the Status menu, the following three options are available:

- Status Messages—Displays diagnostic messages.
- Network Status—Displays performance messages.
- Firmware Version—Displays information about the current firmware version on the phone.

In addition to the status messages available via the Setting Status menu, you can also obtain status messages for a current call.

## Viewing Status Messages

To view status messages that you can use to diagnose network problems, complete the following steps:

- 
- Step 1** Press the **Settings** key. The Settings menu appears.
- Step 2** Highlight **Status**.
- Step 3** Press the **Select** soft key. The Setting Status menu appears.
- Step 4** Highlight **Status Messages**.
- Step 5** Press the **Select** soft key. The Status Messages panel appears.
- Step 6** To exit the Status Messages panel, press the **Exit** soft key.
- 

## Viewing Network Statistics

To view statistical information about the phone and network performance, complete the following steps:

- 
- Step 1** Press the **settings** key. The Settings menu appears.
- Step 2** Highlight **Status**.
- Step 3** Press the **Select** soft key. The Setting Status menu appears.
- Step 4** Highlight **Network Statistics**.

**Step 5** Press the **Select** soft key. The Network Statistics panel appears.

The following information is displayed on this panel:

- Rcv—Number of packets received by the phone; not through the switch.
- Xmit—Number of packets sent by the phone; not through the switch.
- REr—Number of packets received by the phone that contained errors.
- BCast—Number of broadcast packets received by the phone.
- Phone State Message—TCP messages indicating the state of the phone. Possible messages are:
  - Phone Initialized—TCP connection has not gone down since the phone was powered on.
  - Phone Closed TCP—TCP connection was closed by the phone.
  - TCP Timeout—TCP connection was closed because of a retry timeout.
  - Error Code—Error messages indicating unusual reasons the TCP connection was closed.
- Elapsed Time—Length of time (in days, hours, minutes, and seconds) since the last power cycle.
- Port 0 Full, 100—Indicates that the network is in a linked state and has auto-negotiated a full-duplex 100-Mbps connection.
- Port 0 Half, 100—Indicates that the network is in a linked state and has auto-negotiated a half-duplex 100-Mbps connection.
- Port 0 Full, 10—Indicates that the network is in a linked state and has auto-negotiated a full-duplex 10-Mbps connection.
- Port 0 Half, 10—Indicates that the network is in a linked state and has auto-negotiated a half-duplex 10-Mbps connection.
- Port 1 Full, 100—Indicates that the network is in a linked state and has auto-negotiated a full-duplex 100-Mbps connection.
- Port 1 Half, 100—Indicates that the network is in a linked state and has auto-negotiated a half-duplex 100-Mbps connection.
- Port 1 Full, 10—Indicates that the network is in a linked state and has auto-negotiated a full-duplex 10-Mbps connection.
- Port 1 Half, 10—Indicates that the network is in a linked state and has auto-negotiated a half-duplex 10-Mbps connection.

**Step 6** To exit the Network Statistics panel, press the **Exit** soft key.



**Note**

To reset the values displayed on Network Statistics panel, power off and power on the phone.

## Viewing the Firmware Version

To view network statistics, complete the following steps:

**Step 1** Press the **settings** key. The Settings menu appears.

**Step 2** Highlight **Status**.

**Step 3** Press the **Select** soft key. The Setting Status menu appears.

**Step 4** Highlight **Firmware Versions**.

**Step 5** Press the **Select** soft key. The Firmware Versions panel appears.

The following information is displayed on this panel:

- Application Load ID—Current software image on the phone.
- Boot Load ID—Bootstrap loader image version that is manufactured on the phone. This image name does not change.

**Step 6** To exit the Firmware Versions panel, press the **Exit** soft key.

## Upgrading the Cisco SIP IP Phone Firmware

You can use one of two methods to upgrade the firmware on your Cisco SIP IP phones. You can upgrade the firmware on one phone at a time using the phone-specific configuration, or you can upgrade the firmware on a system of phones using the default configuration file.

### Before You Begin

- To upgrade the firmware on just one phone at a time, you upgrade the `image_version` in the phone-specific configuration file. To upgrade the firmware on a system of phones, specify the `image_version` in the default configuration file and do not define the `image_version` in the phone-specific configuration files.
- Ensure that the latest version of the Cisco SIP IP phone firmware has been copied from Cisco.com to the root directory of your TFTP server.

See the upgrade scenarios in Table 3-10 to determine how to upgrade.

**Table 3-10 Upgrade Scenarios**

Image Name	Use Section
POS30100, POS30200, POS30201, and POS3Zxxx	Upgrading from Release 2.1 or Earlier Releases to Release 3.0, page 3-39
P003xxxx or P003xxxxxxxx (these images are loaded on the Cisco SIP IP phone when it is shipped)	Dual Booting from SCCP or MGCP to Release 3.0, page 3-40
P0M3xxxx or P0M3xx-y-zz	Dual Booting from SCCP or MGCP to Release 3.0, page 3-40
POS30202 and POS30203	Upgrading from Release 2.2 or 2.3 to Release 3.0, page 3-39



## Upgrading from Release 2.2 or 2.3 to Release 3.0

- 
- Step 1** Copy the new Release 3.0 binary image POS3xx-y-zz.bin, where *xx* is the release major version, *y* is the release minor version, and *zz* is the maintenance number, from Cisco.com to the root directory of the TFTP server.
- Step 2** Using a text editor, open the configuration file and update the image version specified in the `image_version` variable. The version name in the `image_version` variable should match the version name (without the .bin extension) of the latest firmware that you downloaded (for example, POS3xx-y-zz).
- Step 3** Reset each phone.
- The phone contacts the TFTP server and requests its configuration files. The phone compares the image defined in the file to the image that it has stored in Flash memory. If the phone determines that the image defined in the file differs from the image in Flash memory, it downloads the image defined in the configuration file (which is stored in the root directory on the TFTP server). Once the new image has been downloaded, the phone programs that image into Flash memory and then reboots.
- 



- Note** If you do not define the `image_version` parameter in the default configuration file, only phones that have an updated phone-specific configuration file with the new image version and that have been restarted use the latest firmware image. All other phones use the older version until their configuration files have been updated with the new image version.
- 

## Upgrading from Release 2.1 or Earlier Releases to Release 3.0

- 
- Step 1** Copy the POS30202.bin binary image from Cisco.com to the root directory of the TFTP server.
- Step 2** If you are dual booting from a Cisco IP phone running the Skinny Client Control Protocol (SCCP) or MGCP protocol, open the OS79XX.TXT file with a text editor and change the file to include POS30202.
- Step 3** Open the phone configuration file with a text editor and edit the `image_version` variable to read POS30202.
- Step 4** Reset each phone.
- The phone contacts the TFTP server and requests its configuration files. The phone compares the image defined in the file to the image that it has stored in Flash memory. If the phone determines that the image defined in the file differs from the image in Flash memory, it downloads the image defined in the configuration file (which is stored in the root directory on the TFTP server). Once the new image has been downloaded, the phone programs that image into Flash memory and then reboots.
- Step 5** Copy the new Release 3.0 binary image POS3xx-y-zz.bin, where *xx* is the release major version, *y* is the release minor version, and *zz* is the maintenance number, from Cisco.com to the root directory of the TFTP server.
- Step 6** Using a text editor, open the configuration file and update the image version specified in the `image_version` variable. The version name in `image_version` variable should match the version name (without the .bin extension) of the latest firmware that you downloaded (for example, POS3xx-y-zz).
- Step 7** Reset each phone.
-

## Dual Booting from SCCP or MGCP to Release 3.0

- 
- Step 1** Copy the POS30202.bin binary image from Cisco.com to the root directory of the TFTP server.
- Step 2** If you are dual booting from a Cisco IP phone running the SCCP or MGCP protocol, open the OS79XX.TXT file with a text editor and change the file to include POS30202.
- Step 3** Copy the new Release 3.0 binary image POS3xx-y-zz.bin, where *xx* is the release major version, *y* is the release minor version, and *zz* is the maintenance number, from Cisco.com to the root directory of the TFTP server.
- Step 4** Using a text editor, open the configuration file and update the image version specified in the `image_version` variable. The version name in `image_version` variable should match the version name (without the .bin extension) of the latest firmware that you downloaded (for example, POS3xx-y-zz).
- Step 5** Reset each phone.

The phone contacts the TFTP server and requests its configuration files. The phone compares the image defined in the file to the image that it has stored in Flash memory. If the phone determines that the image defined in the file differs from the image in Flash memory, it downloads the image defined in the configuration file (which is stored in the root directory on the TFTP server). Once the new image has been downloaded, the phone programs that image into Flash memory and then reboots.

## Performing an Image Upgrade and Remote Reboot

With Version 2.0 of the Cisco SIP IP phone, you can perform an image upgrade and remote reboot using Notify messages and the `syncinfo.xml` file.



**Note** To perform an image upgrade and remote reboot, a SIP proxy server and a TFTP server must exist in the phone network.

To upgrade the firmware image and perform a remote reboot, complete the following tasks:

- 
- Step 1** Using an ASCII editor, open the `SIPDefault.cnf` file located in the root directory of your TFTP server and change the `image_version` parameter to the name of the latest image.
- Step 2** Using an ASCII editor, open the `syncinfo.xml` file located in the root directory of your TFTP server and specify values for the image version and sync parameter as follows:

```
<IMAGE VERSION="image_version" SYNC="sync_number" />
```

Where:

- *image\_version* is the image version of the phone. The asterisk (\*) can be used as a wildcard character.
- *sync\_number* is the synchronization level of the phone. The default synchronization level for the phone is 1. A valid value is a character string of up to 32 characters.

- Step 3** Send a NOTIFY message to the phone. In the NOTIFY message, ensure that the an Event header that is equal to “check-sync” is included.

The following is a sample NOTIFY message:

```
NOTIFY sip:lineX_name@ipaddress:5060 SIP/2.0
Via: SIP/2.0/UDP ipaddress:5060;branch=1
Via: SIP/2.0/UDP ipaddress
From: <sip:webadim@ipaddress>
To: <sip:lineX_name@ipaddress>
Event: check-sync
Date: Mon, 10 Jul 2000 16:28:53 -0700
Call-ID: 1349882@ipaddress
CSeq: 1300 NOTIFY
Contact: <sip:webadmin@ipaddress>
Content-Length: 0
```

After the remote reboot process is initiated on the phone via the NOTIFY message, the following actions take place:

1. If the phone is currently in an idle state, the phone waits 20 seconds and then contacts the TFTP server for the syncinfo.xml file. If the phone is not in an idle state, the phone waits until it is in an idle state for 20 seconds and then contacts the TFTP server for the syncinfo.xml file.
2. The phone reads the syncinfo.xml file and performs the following as appropriate:
  - a. Determines whether the current image is specified. If so, the phone proceeds to Step c. If not, the phone proceeds to Step b.
  - b. Determines whether there is a wildcard entry (\*) in the image version parameter. If so, the phone proceeds to Step c. If not, the phone proceeds to Step d.
  - c. Determines if the synchronization value is different than what is stored on the phone. If so, the phone proceeds to Step e. If not, the phone proceeds to Step d.
  - d. The phone does nothing.
  - e. The phone reboots.

The phone then performs a normal reboot process as described in the “Initialization Process Overview” section on page 2-1, sees the new image, and upgrades to the new image with a synchronization value of what is specified in the syncinfo.xml file.





## SIP Compliance with RFC 2543 Information

---

This section describes how the Cisco SIP IP phone complies with the IETF definition of SIP as described in RFC 2543.

This section contains compliance information on the following:

- SIP Functions, page A-1
- SIP Methods, page A-1
- SIP Responses, page A-2
- SIP Header Fields, page A-7
- SIP Session Description Protocol (SDP) Usage, page A-8
- Transport Layer Protocols, page A-9
- SIP Security, page A-9
- SIP DTMF Digit Transport, page A-9

### SIP Functions

Function	Supported?
User agent client (UAC)	Yes
User agent server (UAS)	Yes
Proxy server	Third-party only
Redirect server	Third-party only

### SIP Methods

The following SIP methods are supported:

Method	Supported?	Comments
INVITE	Yes	The Cisco SIP IP phone supports mid-call changes such as putting a call on hold as signaled by a new INVITE that contains an existing call ID.
ACK	Yes	None.
OPTIONS	Response only	
BYE	Yes	
CANCEL	Yes	
REGISTER	Yes	The Cisco SIP IP phone supports both user and device registration.
REFER	Yes	None.
NOTIFY	Yes	Used for REFER and remote reboot.

## SIP Responses

Release 1.0 of the Cisco SIP IP phone supports the following SIP responses:

- 1xx Response—Information Responses, page A-2
- 2xx Response—Successful Responses, page A-3
- 3xx Response—Redirection Responses, page A-3
- 4xx Response—Request Failure Responses, page A-4
- 5xx Response—Server Failure Responses, page A-6
- 6xx Response—Global Responses, page A-7

### 1xx Response—Information Responses

1xx Response	Supported?	Comments
100 Trying	Yes	The Cisco SIP IP phone generates this response for an incoming INVITE. Upon receiving this response, the phone waits for a 180 Ringing, 183 Session progress, or 200 OK response.
180 Ringing	Yes	None

1xx Response	Supported?	Comments
181 Call Is Being Forwarded	See comments	The Cisco SIP IP phone does not generate these responses,; however, the phone does receive them. The phone processes these responses the same way that it processes the 100 Trying response.
182 Queued		
183 Session Progress		The SIP IP phone does not generate this message. Upon receiving this response, the phone provides early media cut-through and then waits for a 200 OK response.

## 2xx Response—Successful Responses

2xx Response	Supported?	Comments
200 OK	Yes	None
202 Accepted	Yes	None

## 3xx Response—Redirection Responses

3xx Response	Supported?	Comments
300 Multiple Choices	Yes	None
301 Moved Permanently	Yes	
302 Moved Temporarily	Yes	The Cisco SIP IP phone does not generate this response at this time. Upon receiving this response, the phone sends an INVITE containing the contact information received in the 302 Moved temporarily response.
305 Use Proxy	Yes	The phone does not generate these responses. The gateway contacts the new address in the Contact header field.
380 Alternate Service	Yes	

## 4xx Response—Request Failure Responses

4xx Response	Supported?	Comments
400 Bad Request	Yes	The phone generates a 400 Bad Request response for an erroneous request. For an incoming response, the phone initiates a graceful call disconnect (during which the caller hears a busy or fast busy tone) before clearing the call request.
401 Unauthorized	Yes	This response is received only in this release. If a 401 Unauthorized response is received during registration, the phone accepts the response and sends a new request that contains the user's authentication information in the format of the HTTP digest as modified by RFC 2543.
402 Payment Required	Yes	The phone does not generate the 402 Payment Required response.
403 Forbidden	Yes	This response is received only in this release. If the phone receives a 403 Forbidden response, it notifies the user of the response. This response indicates that the SIP server has the request but will not provide service.
404 Not Found	Yes	The Cisco SIP IP phone generates this response if it is unable to locate the callee. Upon receiving this response, the phone notifies the user.
405 Method Not Allowed	See comments	This response is received only in this release. If the phone receives a 405 Method Not Allowed response, it notifies the user of the response.
406 Not Acceptable	See comments	The SIP phone does not generate a 406 Not Acceptable response. For an incoming response, the gateway initiates a graceful call disconnect (during which the caller hears a busy or fast busy tone) before clearing the call request.
407 Proxy Authentication Required	See comments	This response is received only in this release. The 407 Proxy Authentication Required response indicates that the phone must first authenticate itself with the proxy server. If received by the phone, the phone may repeat the INVITE request with a suitable Proxy-Authorization field. This field should contain the authentication information of the user agent for the next outbound proxy or gateway.



4xx Response	Supported?	Comments
408 Request Timeout	See comments	The SIP phone does not generate a 408 Request Timeout response. For an incoming response, the gateway initiates a graceful call disconnect (during which the caller hears a busy or fast busy tone) before clearing the call request.
409 Conflict	See comments	This response is received only by the phone in this release.  The 409 Conflict response indicates that the INVITE request could not be processed because of a conflict with the current state of the resource. If this response is received, the user is notified.
410 Gone	See comments	This response is received by the phone only in this release.  The 410 Gone response indicates that a resource is no longer available at the server and no forwarding address is known.
411 Length Required	See comments	This response is received by the phone only in this release.  This response indicates that the user refuses to accept the request without a defined content length. If received, the phone resends the INVITE request if it can add a valid Content-Length header field.
413 Request Entity Too Large	See comments	This response is received only by the phone in this release.  If a retry after header field is contained in this response, then the user can attempt the call once again in the retry time provided.
414 Request—URL Too Long	See comments	This response is received only by the phone in this release. The user is notified if this response is received.
415 Unsupported Media	See comments	This response is received only by the phone in this release. The user is notified if this response is received.
420 Bad Extension	See comments	This response is received only by the phone in this release. The user is notified if this response is received.  If the phone does not understand the protocol extension specified in the Require field, the 420 Bad Extension response is generated.

4xx Response	Supported?	Comments
480 Temporarily Unavailable	See comments	This response is received only by the phone in this release. The user is notified if this response is received.  If this response is received, the user is notified that the callee is temporarily unavailable (perhaps not logged on), and any retry information is displayed.
481 Call Leg/Transaction Does Not Exist	See comments	This response is received only by the phone in this release. The user is notified if this response is received.
482 Loop Detected		
483 Too Many Hops		
484 Address Incomplete		
485 Ambiguous	See comments	This response is received only by the phone in this release.  If a new contact is received, the phone might reinitiate the call.
486 Busy Here	Yes	The Cisco SIP IP phone generates this response if the called party is off-hook and the call cannot be presented as a call-waiting call. Upon receiving this response, the phone notifies the user and generates a busy tone.
487 Request Canceled	Yes	This response indicates that the initial request is terminated with a BYE or CANCEL request.
488 Not Acceptable	Yes	The Cisco SIP IP phone receives and generates this response.

## 5xx Response—Server Failure Responses

5xx Response	Comments
500 Internal Server Error	The Cisco SIP IP phone does not generate these 5xx responses. For an incoming response, the SIP IP phone initiates a graceful call disconnect.
501 Not Implemented	
502 Bad Gateway	
503 Service Unavailable	
504 Gateway Timeout	
505 Version Not Supported	

## 6xx Response—Global Responses

6xx Response	Comments
600 Busy Everywhere	The Cisco SIP IP phone does not generate these 6xx responses. For an incoming response, the SIP IP phone initiates a graceful call disconnect.
603 Decline	
604 Does Not Exist Anywhere	
606 Not Acceptable	

## SIP Header Fields

Header Field	Supported?
Accept	Yes
Accept-Encoding	Yes
Accept-Language	Yes
Allow	Yes
Also	Yes
Authorization	Yes
Call-ID	Yes
Contact	Yes
Content-Encoding	Yes
Content-Length	Yes
Content-Type	Yes
Cseq	Yes
Date	Yes
Encryption	No
Expires	Yes
From	Yes
Hide	No
Max-Forwards	Yes
Organization	No
Priority	No
Proxy-Authenticate	Yes

Header Field	Supported?
Proxy-Authorization	Yes
Proxy-Require	Yes
Record-Route	Yes
Referred-By	Yes
Referred-To	Yes
Replaces	Yes
Requested-By	Yes
Require	Yes
Response-Key	No
Retry-After	Yes
Route	Yes
Server	Yes
Subject	No
Timestamp	Yes
To	Yes
Unsupported	Yes
User-Agent	Yes
Via	Yes
Warning	Yes
WWW-Authenticate	Yes

## SIP Session Description Protocol (SDP) Usage

SDP Headers	Supported?
v—Protocol version	Yes
o—Owner or creator and session identifier	Yes
s—Session name	Yes
t—Time description	Yes
c—Connection information	Yes
m—Media name and transport address	Yes

SDP Headers	Supported?
a—Media attribute lines	Yes

## Transport Layer Protocols

Protocol	Supported?
Unicast UDP	Yes
Multicast UDP	No
TCP	No

## SIP Security

### Authentication

<b>Basic Authentication</b>	<b>No</b>
Digest Authentication	Yes
Proxy Authentication	No
PGP	No

### SIP DNS Records Usage

DNS Resource Record Type	Supported?
Type A	Yes
Type SRV	Yes

## SIP DTMF Digit Transport

Transport Type	Supported?
RFC 2833	Yes
In-band tones	Yes





## SIP Call Flows

---

This chapter includes the following sections:

- Call Flow Scenarios for Successful Calls, page B-1
- Call Flow Scenarios for Failed Calls, page B-46

SIP uses the following request methods:

- INVITE—Indicates that a user or service is being invited to participate in a call session.
- ACK—Confirms that the client has received a final response to an INVITE request.
- BYE—Terminates a call and can be sent by either the caller or the callee.
- CANCEL—Cancels any pending searches but does not terminate a call that has already been accepted.
- OPTIONS—Queries the capabilities of servers.
- REGISTER—Registers the address listed in the To header field with a SIP server.
- REFER—Indicates that the user (recipient) should contact a third party for use in transferring parties.
- NOTIFY—Notifies the user of the status of a transfer using REFER. Also used for remote reset.

The following types of responses are used by SIP and generated by the Cisco SIP gateway:

- SIP 1xx—Informational Responses
- SIP 2xx—Successful Responses
- SIP 3xx—Redirection Responses
- SIP 4xx—Client Failure Responses
- SIP 5xx—Server Failure Responses
- SIP 6xx—Global Failure Responses

## Call Flow Scenarios for Successful Calls

This section describes call flows for the following scenarios, which illustrate successful calls:

- Gateway-to-Cisco SIP IP Phone—Successful Call Setup and Disconnect, page B-2
- Gateway-to-Cisco SIP IP Phone—Successful Call Setup and Call Hold, page B-4
- Cisco SIP IP Phone-to-Cisco SIP IP Phone Simple Call Hold, page B-6

- Cisco SIP IP Phone-to-Cisco SIP IP Phone Call Hold with Consultation, page B-9
- Cisco SIP IP Phone-to-Cisco SIP IP Phone Call Waiting, page B-13
- Cisco SIP IP Phone-to-Cisco SIP IP Phone Call Transfer Without Consultation, page B-17
- Cisco SIP IP Phone-to-Cisco SIP IP Phone Call Transfer Without Consultation Using Failover to Bye/Also, page B-21
- Cisco SIP IP Phone-to-Cisco SIP IP Phone Call Transfer with Consultation, page B-25
- Cisco SIP IP Phone-to-Cisco SIP IP Phone Call Transfer with Consultation Using Failover to Bye/Also, page B-30
- Cisco SIP IP Phone-to-Cisco SIP IP Phone Network Call Forwarding (Unconditional), page B-35
- Cisco SIP IP Phone-to-Cisco SIP IP Phone Network Call Forwarding (Busy), page B-37
- Cisco SIP IP Phone-to-Cisco SIP IP Phone Network Call Forwarding (No Answer), page B-39
- Cisco SIP IP Phone-to Cisco SIP IP Phone Three-Way Calling, page B-42

## Gateway-to Cisco SIP IP Phone—Successful Call Setup and Disconnect

Figure B-1 illustrates a successful gateway-to-Cisco SIP IP phone call setup and disconnect. In this scenario, the two end users are User A and User B. User A is located at PBX A. PBX A is connected to Gateway 1 (SIP Gateway) via a T1/E1. User B is located at a Cisco SIP IP phone. Gateway 1 is connected to the Cisco SIP IP phone over an IP network.

The call flow is as follows:

1. User A calls User B.
2. User B answers the call.
3. User B hangs up.



Figure B-1 Gateway-to-Cisco SIP IP Phone—Successful Setup and Disconnect

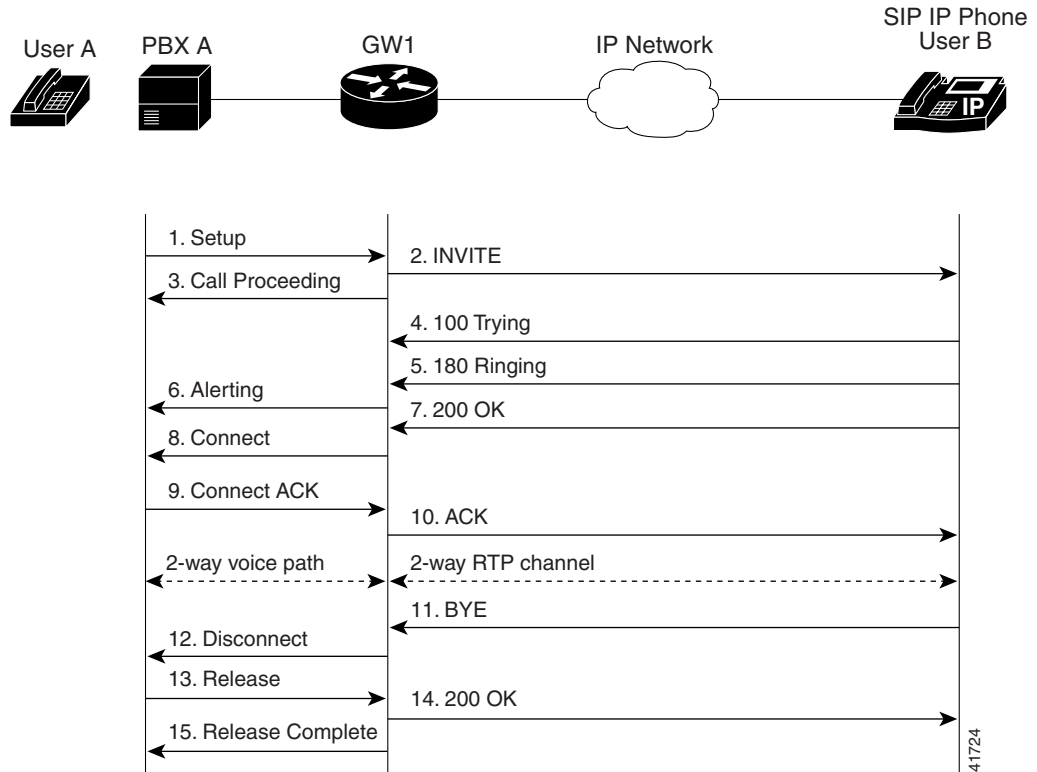

Step	Action	Description
1.	Setup—PBX A to Gateway 1	Call Setup is initiated between PBX A and Gateway 1. The Call Setup includes the standard transactions that take place as User A attempts to call User B.
2.	INVITE—Gateway 1 to Cisco SIP IP phone	Gateway 1 maps the SIP URL phone number to a dial peer. The dial peer includes the IP address and the port number of the SIP-enabled entity to contact. Gateway 1 sends a SIP INVITE request to the address it receives as the dial peer, which, in this scenario, is the Cisco SIP IP phone.  In the INVITE request: <ul style="list-style-type: none"> <li>• The IP address of the Cisco SIP IP phone is inserted in the Request-URI field.</li> <li>• PBX A is identified as the call session initiator in the From field.</li> <li>• A unique numeric identifier is assigned to the call and is inserted in the Call-ID field.</li> <li>• The transaction number within a single call leg is identified in the CSeq field.</li> <li>• The media capability User A is ready to receive is specified.</li> <li>• The port on which the Gateway is prepared to receive the RTP data is specified.</li> </ul>
3.	Call Proceeding—Gateway 1 to PBX A	Gateway 1 sends a Call Proceeding message to PBX A to acknowledge the Call Setup request.

Step	Action	Description
4.	100 Trying—Cisco SIP IP phone to Gateway 1	The Cisco SIP IP phone sends a SIP 100 Trying response to Gateway 1. The 100 Trying response indicates that the INVITE request has been received by the Cisco SIP IP phone.
5.	180 Ringing—Cisco SIP IP phone to Gateway 1	The Cisco SIP IP phone sends a SIP 180 Ringing response to Gateway 1. The 180 Ringing response indicates that the user is being alerted.
6.	Alerting—Gateway 1 to PBX A	Gateway 1 sends an Alert message to User A. The Alert message indicates that Gateway 1 has received a 180 Ringing response from the Cisco SIP IP phone. User A hears the ringback tone that indicates that User B is being alerted.
7.	200 OK—Cisco SIP IP phone to Gateway 1	The Cisco SIP IP phone sends a SIP 200 OK response to Gateway 1. The 200 OK response notifies Gateway 1 that the connection has been made.
8.	Connect—Gateway 1 to PBX A	Gateway 1 sends a Connect message to PBX A. The Connect message notifies PBX A that the connection has been made.
9.	Connect ACK—PBX A to Gateway 1	PBX A acknowledges Gateway 1's Connect message.
10.	ACK—Gateway 1 to Cisco SIP IP phone	Gateway 1 sends a SIP ACK to the Cisco SIP IP phone. The ACK confirms that Gateway 1 has received the 200 OK response. The call session is now active.
11.	BYE—Cisco SIP IP phone to Gateway 1	User B terminates the call session at his Cisco SIP IP phone and the phone sends a SIP BYE request to Gateway 1. The BYE request indicates that User B wants to release the call.
12.	Disconnect—Gateway 1 to PBX A	Gateway 1 sends a Disconnect message to PBX A.
13.	Release—PBX A to Gateway 1	PBX A sends a Release message to Gateway 1.
14.	200 OK—Gateway 1 to Cisco SIP IP phone	Gateway 1 sends a SIP 200 OK response to the Cisco SIP IP phone. The 200 OK response notifies the phone that Gateway 1 has received the BYE request.
15.	Release Complete—Gateway 1 to PBX A	Gateway 1 sends a Release Complete message to PBX A and the call session is terminated.

## Gateway-to-Cisco SIP IP Phone—Successful Call Setup and Call Hold

Figure B-2 illustrates a successful gateway-to-Cisco SIP IP phone call setup and call hold. In this scenario, the two end users are User A and User B. User A is located at PBX A. PBX A is connected to Gateway 1 (SIP Gateway) via a T1/E1. User B is located at a Cisco SIP IP phone. Gateway 1 is connected to the Cisco SIP IP phone over an IP network.

The call flow is as follows:

1. User A calls User B.
2. User B answers the call.
3. User B puts User A on hold.
4. User B takes User A off hold.

Figure B-2 Gateway-to-Cisco SIP IP Phone Call—Successful Call Setup and Call Hold

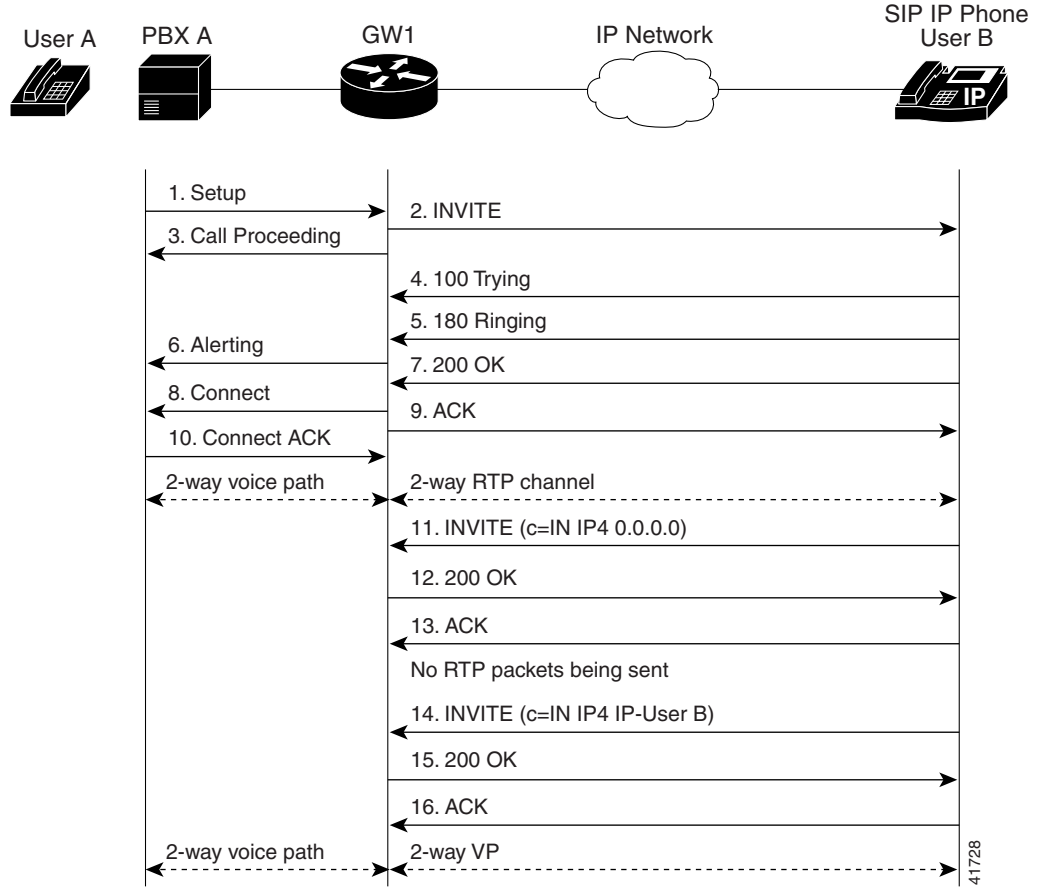

Step	Action	Description
1.	Setup—PBX A to Gateway 1	Call setup is initiated between PBX A and Gateway 1. The call setup includes the standard transactions that take place as User A attempts to call User B.
2.	INVITE—Gateway 1 to Cisco SIP IP phone	<p>Gateway 1 maps the SIP URL phone number to a dial peer. The dial peer includes the IP address and the port number of the SIP enabled entity to contact. Gateway 1 sends a SIP INVITE request to the address it receives as the dial peer, which, in this scenario, is the Cisco SIP IP phone.</p> <p>In the INVITE request:</p> <ul style="list-style-type: none"> <li>The IP address of the Cisco SIP IP phone is inserted in the Request-URI field.</li> <li>PBX A is identified as the call session initiator in the From field.</li> <li>A unique numeric identifier is assigned to the call and is inserted in the Call-ID field.</li> <li>The transaction number within a single call leg is identified in the CSeq field.</li> <li>The media capability User A is ready to receive is specified.</li> <li>The port on which the gateway is prepared to receive the RTP data is specified.</li> </ul>

Step	Action	Description
3.	Call Proceeding—Gateway 1 to PBX A	Gateway 1 sends a Call Proceeding message to PBX A to acknowledge the Call Setup request.
4.	100 Trying—Cisco SIP IP phone to Gateway 1	The Cisco SIP IP phone sends a SIP 100 Trying response to Gateway 1. The 100 Trying response indicates that the INVITE request has been received by the Cisco SIP IP phone.
5.	180 Ringing—Cisco SIP IP phone to Gateway 1	The Cisco SIP IP phone sends a SIP 180 Ringing response to Gateway 1. The 180 Ringing response indicates that the user is being alerted.
6.	Alerting—Gateway 1 to PBX A	Gateway 1 sends an Alert message to User A. The Alert message indicates that Gateway 1 has received a 180 Ringing response from the Cisco SIP IP phone. User A hears the ringback tone that indicates that User B is being alerted.
7.	200 OK—Cisco SIP IP phone to Gateway 1	The Cisco SIP IP phone sends a SIP 200 OK response to Gateway 1. The 200 OK response notifies Gateway 1 that the connection has been made.
8.	Connect—Gateway 1 to PBX A	Gateway 1 sends a Connect message to PBX A. The Connect message notifies PBX A that the connection has been made.
9.	ACK—Gateway 1 to Cisco SIP IP phone	Gateway 1 sends a SIP ACK to the Cisco SIP IP phone. The ACK confirms that User A has received the 200 OK response. The call session is now active.
10.	Connect ACK—PBX A to Gateway 1	PBX A acknowledges Gateway 1's Connect message.
11.	INVITE—Cisco SIP IP phone to Gateway 1	User B puts User A on hold. The Cisco SIP IP phone sends a SIP INVITE request to Gateway 1.
12.	200 OK—Gateway 1 to Cisco SIP IP phone	Gateway 1 sends a SIP 200 OK response to the Cisco SIP IP phone. The 200 OK response notifies the Cisco SIP IP phone that the INVITE was successfully processed.
13.	ACK—Cisco SIP IP phone to Gateway 1	The Cisco SIP IP phone sends a SIP ACK to Gateway 1. The ACK confirms that the Cisco SIP IP phone has received the 200 OK response. The call session is now temporarily inactive. No RTP packets are being sent.
14.	INVITE—Cisco SIP IP phone to Gateway 1	User B takes User A off hold. The Cisco SIP IP phone sends a SIP INVITE request to Gateway 1.
15.	200 OK—Gateway 1 to Cisco SIP IP phone	Gateway 1 sends a SIP 200 OK response to the Cisco SIP IP phone. The 200 OK response notifies the Cisco SIP IP phone that the INVITE was successfully processed.
16.	ACK—Cisco SIP IP phone to Gateway 1	The Cisco SIP IP phone sends a SIP ACK to Gateway 1. The ACK confirms that the Cisco SIP IP phone has received the 200 OK response. The call session is now active.

## Cisco SIP IP Phone-to-Cisco SIP IP Phone Simple Call Hold

Figure B-3 illustrates a successful call between Cisco SIP IP phones in which one of the participants places the other on hold and then returns to the call. In this call flow scenario, the two end users are User A and User B. User A and User B are both using Cisco SIP IP phones, which are connected via an IP network.

The call flow scenario is as follows:

1. User A calls User B.
2. User B answers the call.

3. User B places User A on hold.
4. User B takes User A off hold.
5. The call continues.

**Figure B-3 Cisco SIP IP Phone-to-Cisco SIP IP Phone Simple Call Hold**

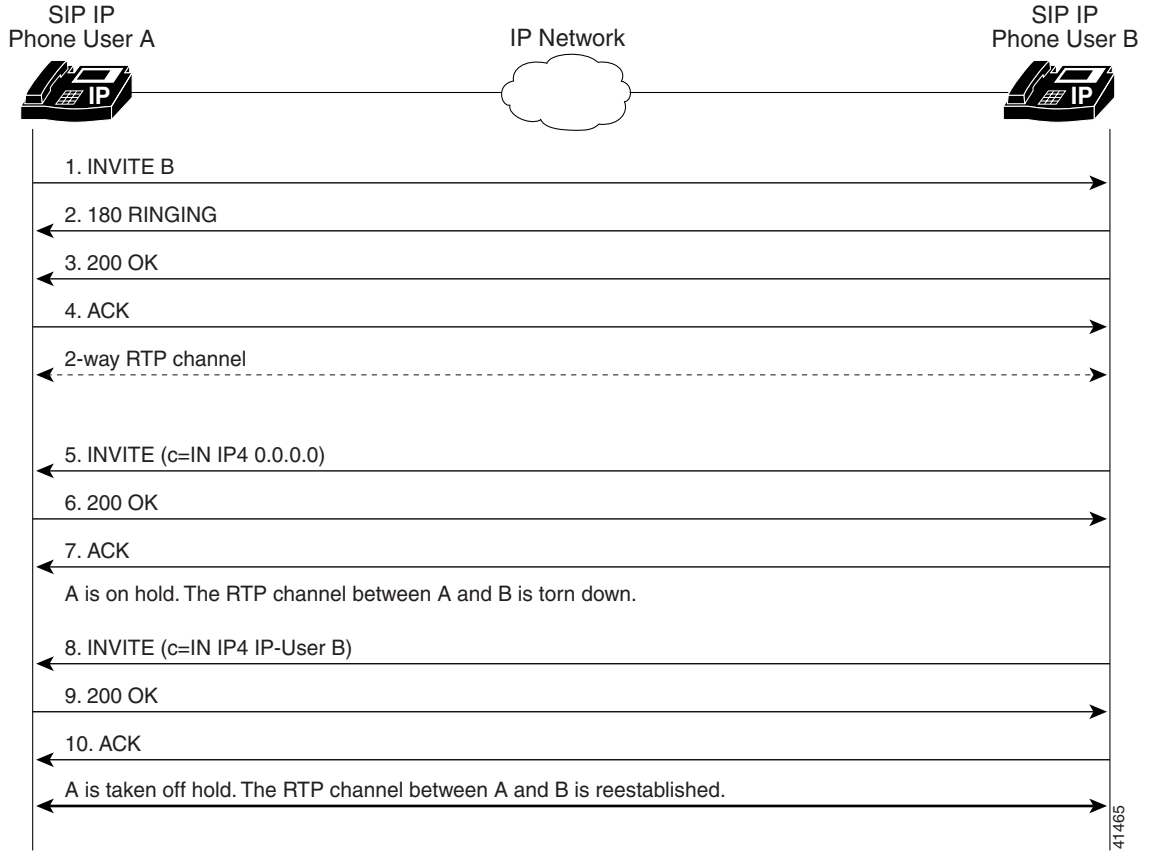

Step	Action	Description
1.	INVITE—Cisco SIP IP phone A to Cisco SIP IP phone B	<p>Cisco SIP IP phone A sends a SIP INVITE request to Cisco SIP IP phone B. The INVITE request is an invitation to User B to participate in a call session.</p> <p>In the INVITE request:</p> <ul style="list-style-type: none"> <li>The phone number of User B is inserted in the Request-URI field in the form of a SIP URL. The SIP URL identifies the address of User B and takes a form similar to an e-mail address (<i>user@host</i>, where <i>user</i> is the telephone number and <i>host</i> is either a domain name or a numeric network address). For example, the Request-URI field in the INVITE request to User B appears as “INVITE sip:555-0002@companyb.com; user=phone.” The “user=phone” parameter distinguishes that the Request-URI address is a telephone number rather than a username.</li> <li>Cisco SIP IP phone A is identified as the call session initiator in the From field.</li> <li>A unique numeric identifier is assigned to the call and is inserted in the Call-ID field.</li> <li>The transaction number within a single call leg is identified in the CSeq field.</li> <li>The media capability User A is ready to receive is specified.</li> </ul>
2.	180 Ringing—Cisco SIP IP phone B to Cisco SIP IP phone A	Cisco SIP IP phone B sends a SIP 180 Ringing response to Cisco SIP IP phone A.
3.	200 OK—Cisco SIP IP phone B to Cisco SIP IP phone A	<p>Cisco SIP IP phone B sends a SIP 200 OK response to Cisco SIP IP phone A. The 200 OK response notifies Cisco SIP IP phone A that the connection has been made.</p> <p>If Cisco SIP IP phone B supports the media capability advertised in the INVITE message sent by Cisco SIP IP phone A, it advertises the intersection of its own and Cisco SIP IP phone A’s media capability in the 200 OK response. If Cisco SIP IP phone B does not support the media capability advertised by Cisco SIP IP phone A, it sends back a 400 Bad Request response with a 304 Warning header field.</p>
4.	ACK—Cisco SIP IP phone A to Cisco SIP IP phone B	<p>Cisco SIP IP phone A sends a SIP ACK to Cisco SIP IP phone B. The ACK confirms that Cisco SIP IP phone A has received the 200 OK response from Cisco SIP IP phone B.</p> <p>The ACK might contain a message body with the final session description to be used by Cisco SIP IP phone B. If the message body of the ACK is empty, Cisco SIP IP phone B uses the session description in the INVITE request.</p>
A two-way RTP channel is established between Cisco SIP IP phone A and Cisco SIP IP phone B.		
5.	INVITE—Cisco SIP IP phone B to Cisco SIP IP phone A	<p>Cisco SIP IP phone B sends a mid-call INVITE to Cisco SIP IP phone A with new Session Description Protocol (SDP) session parameters (IP address), which are used to place the call on hold.</p> <pre>Call_ID=1 SDP: c=IN IP4 0.0.0.0</pre> <p>The c= SDP field of the SIP INVITE contains an 0.0.0.0. This places the call in hold.</p>

Step	Action	Description
6.	200 OK—Cisco SIP IP phone A to Cisco SIP IP phone B	Cisco SIP IP phone A sends a SIP 200 OK response to Cisco SIP IP phone B.
7.	ACK—Cisco SIP IP phone B to Cisco SIP IP phone A	Cisco SIP IP phone B sends a SIP ACK to Cisco SIP IP phone A. The ACK confirms that Cisco SIP IP phone B has received the 200 OK response from Cisco SIP IP phone A.
The RTP channel between Cisco SIP IP phone A and Cisco SIP IP phone B is torn down.		
8.	INVITE—Cisco SIP IP phone B to Cisco SIP IP phone A	<p>Cisco SIP IP phone B sends a mid-call INVITE to Cisco SIP IP phone A with the same call ID as the previous INVITE and new SDP session parameters (IP address), which are used to reestablish the call.</p> <pre>Call_ID=1 SDP: c=IN IP4 181.23.250.2</pre> <p>To reestablish the call between phone A and phone B, the IP address of phone B is inserted into the c= SDP field.</p>
9.	200 OK—Cisco SIP IP phone A to Cisco SIP IP phone B	Cisco SIP IP phone A sends a SIP 200 OK response to Cisco SIP IP phone B.
10.	ACK—Cisco SIP IP phone B to Cisco SIP IP phone A	Cisco SIP IP phone B sends a SIP ACK to Cisco SIP IP phone A. The ACK confirms that Cisco SIP IP phone B has received the 200 OK response from Cisco SIP IP phone A.

A two-way RTP channel is reestablished between IP phone A and IP phone B.

## Cisco SIP IP Phone-to-Cisco SIP IP Phone Call Hold with Consultation

Figure B-4 illustrates a successful call between Cisco SIP IP phones in which one of the participants places the other on hold, calls a third party (consultation), and then returns to the original call. In this call flow scenario, the end users are User A, User B, and User C. They are all using Cisco SIP IP phones, which are connected via an IP network.

The call flow scenario is as follows:

1. User A calls User B.
2. User B answers the call.
3. User B places User A on hold.
4. User B calls User C.
5. User B disconnects from User C.
6. User B takes User A off hold.
7. The original call continues.

Figure B-4 Cisco SIP IP Phone-to-Cisco SIP IP Phone Call Hold with Consultation

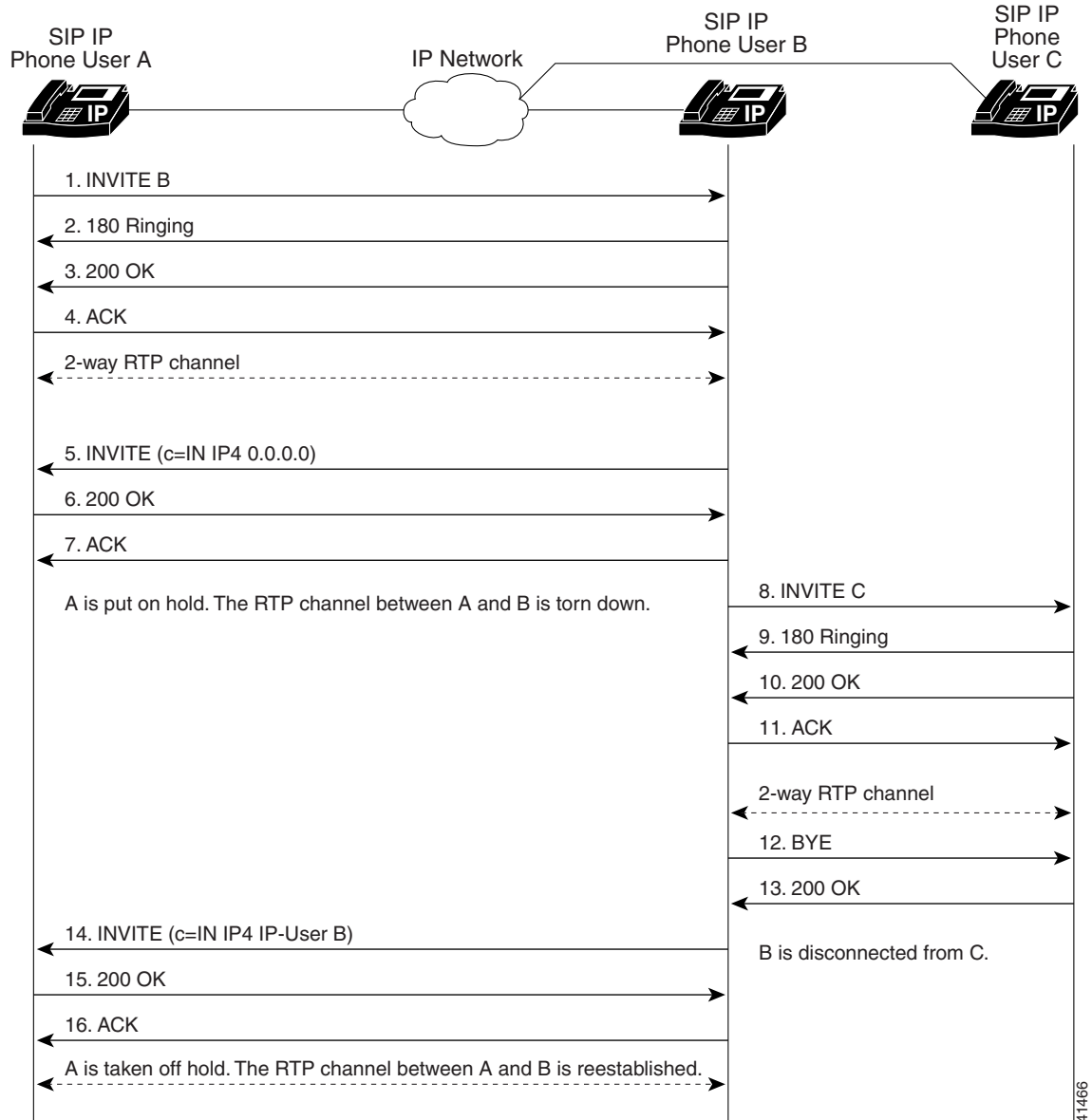



Step	Action	Description
1.	INVITE—Cisco SIP IP phone A to Cisco SIP IP phone B	<p>Cisco SIP IP phone A sends a SIP INVITE request to Cisco SIP IP phone B. The INVITE request is an invitation to User B to participate in a call session.</p> <p>In the INVITE request:</p> <ul style="list-style-type: none"> <li>• The phone number of User B is inserted in the Request-URI field in the form of a SIP URL. The SIP URL identifies the address of User B and takes a form similar to an e-mail address (<i>user@host</i>, where <i>user</i> is the telephone number and <i>host</i> is either a domain name or a numeric network address). For example, the Request-URI field in the INVITE request to User B appears as “INVITE sip:555-0002@companyb.com; user=phone.” The “user=phone” parameter distinguishes that the Request-URI address is a telephone number rather than a username.</li> <li>• Cisco SIP IP phone A is identified as the call session initiator in the From field.</li> <li>• A unique numeric identifier is assigned to the call and is inserted in the Call-ID field.</li> <li>• The transaction number within a single call leg is identified in the CSeq field.</li> <li>• The media capability User A is ready to receive is specified.</li> </ul>
2.	180 Ringing—Cisco SIP IP phone B to Cisco SIP IP phone A	Cisco SIP IP phone B sends a SIP 180 Ringing response to Cisco SIP IP phone A.
3.	200 OK—Cisco SIP IP phone B to Cisco SIP IP phone A	<p>Cisco SIP IP phone B sends a SIP 200 OK response to Cisco SIP IP phone A. The 200 OK response notifies Cisco SIP IP phone A that the connection has been made.</p> <p>If Cisco SIP IP phone B supports the media capability advertised in the INVITE message sent by Cisco SIP IP phone A, it advertises the intersection of its own and Cisco SIP IP phone A’s media capability in the 200 OK response. If Cisco SIP IP phone B does not support the media capability advertised by Cisco SIP IP phone A, it sends back a 400 Bad Request response with a 304 Warning header field.</p>
4.	ACK—Cisco SIP IP phone A to Cisco SIP IP phone B	<p>Cisco SIP IP phone A sends a SIP ACK to Cisco SIP IP phone B. The ACK confirms that Cisco SIP IP phone A has received the 200 OK response from Cisco SIP IP phone B.</p> <p>The ACK might contain a message body with the final session description to be used by Cisco SIP IP phone B. If the message body of the ACK is empty, Cisco SIP IP phone B uses the session description in the INVITE request.</p>
A two-way RTP channel is established between Cisco SIP IP phone A and Cisco SIP IP phone B.		
5.	INVITE—Cisco SIP IP phone B to Cisco SIP IP phone A	<p>Cisco SIP IP phone B sends a mid-call INVITE to Cisco SIP IP phone A with new SDP session parameters (IP address), which are used to place the call on hold.</p> <pre>Call_ID=1 SDP: c=IN IP4 0.0.0.0</pre> <p>The c= SDP field of the SIP INVITE contains 0.0.0.0. This places the call in hold.</p>

Step	Action	Description
6.	200 OK—Cisco SIP IP phone A to Cisco SIP IP phone B	Cisco SIP IP phone A sends a SIP 200 OK response to Cisco SIP IP phone B.
7.	ACK—Cisco SIP IP phone B to Cisco SIP IP phone A	Cisco SIP IP phone B sends a SIP ACK to Cisco SIP IP phone A. The ACK confirms that Cisco SIP IP phone B has received the 200 OK response from Cisco SIP IP phone A.

The RTP channel between Cisco SIP IP phone A and Cisco SIP IP phone B is torn down.

8.	INVITE—Cisco SIP IP phone B to Cisco SIP IP phone C	Cisco SIP IP phone B sends a SIP INVITE request to Cisco SIP IP phone C. The INVITE request is an invitation to User C to participate in a call session.
9.	180 Ringing—Cisco SIP IP phone C to Cisco SIP IP phone B	Cisco SIP IP phone C sends a SIP 180 Ringing response to Cisco SIP IP phone B.
10.	200 OK—Cisco SIP IP phone C to Cisco SIP IP phone B	<p>Cisco SIP IP phone C sends a SIP 200 OK response to Cisco SIP IP phone B. The 200 OK response notifies Cisco SIP IP phone B that the connection has been made.</p> <p>If Cisco SIP IP phone B supports the media capability advertised in the INVITE message sent by Cisco SIP IP phone A, it advertises the intersection of its own and Cisco SIP IP phone A's media capability in the 200 OK response. If Cisco SIP IP phone B does not support the media capability advertised by Cisco SIP IP phone A, it sends back a 400 Bad Request response with a 304 Warning header field.</p>
11.	ACK—Cisco SIP IP phone B to Cisco SIP IP phone C	<p>Cisco SIP IP phone B sends a SIP ACK to Cisco SIP IP phone C. The ACK confirms that Cisco SIP IP phone B has received the 200 OK response from Cisco SIP IP phone C.</p> <p>The ACK might contain a message body with the final session description to be used by Cisco SIP IP phone C. If the message body of the ACK is empty, Cisco SIP IP phone C uses the session description in the INVITE request.</p>

A two-way RTP channel is established between Cisco SIP IP phone B and Cisco SIP IP phone C.

12.	BYE—Cisco SIP IP phone B to Cisco SIP IP phone C	The call continues and then User B hangs up. Cisco SIP IP phone B sends a SIP BYE request to Cisco SIP IP phone C. The BYE request indicates that User B wants to release the call.
13.	200 OK—Cisco SIP IP phone C to Cisco SIP IP phone B	Cisco SIP IP phone C sends a SIP 200 OK message to Cisco SIP IP phone B. The 200 OK response notifies Cisco SIP IP phone B that the BYE request has been received. The call session between User A and User B is now terminated.

The RTP channel between Cisco SIP IP phone B and Cisco SIP IP phone C is torn down.

14.	INVITE—Cisco SIP IP phone B to Cisco SIP IP phone A	<p>Cisco SIP IP phone B sends a mid-call INVITE to Cisco SIP IP phone A with the same call ID as the previous INVITE and new SDP session parameters (IP address), which are used to reestablish the call.</p> <pre>Call_ID=1 SDP: c=IN IP4 181.23.250.2</pre> <p>To reestablish the call between phone A and phone B, the IP address of phone B is inserted into the c= SDP field.</p>
15.	200 OK—Cisco SIP IP phone A to Cisco SIP IP phone B	Cisco SIP IP phone A sends a SIP 200 OK response to Cisco SIP IP phone B.

Step	Action	Description
16.	ACK—Cisco SIP IP phone B to Cisco SIP IP phone A	Cisco SIP IP phone B sends a SIP ACK to Cisco SIP IP phone A. The ACK confirms that Cisco SIP IP phone B has received the 200 OK response from Cisco SIP IP phone A.

A two-way RTP channel is reestablished between Cisco SIP IP phone A and Cisco SIP IP phone B.

## Cisco SIP IP Phone-to-Cisco SIP IP Phone Call Waiting

Figure B-5 illustrates a successful call between Cisco SIP IP phones in which two parties are in a call, one of the participants receives a call from a third party, and then returns to the original call. In this call flow scenario, the end users are User A, User B, and User C. They are all using Cisco SIP IP phones, which are connected via an IP network.

The call flow scenario is as follows:

1. User A calls User B.
2. User B answers the call.
3. User C calls User B.
4. User B accepts the call from User C.
5. User B switches back to User A.
6. User B hangs up, ending the call with User A.
7. User B is notified of the remaining call with User C.
8. User B answers the notification and continues the call with User C.

Figure B-5 Cisco SIP IP Phone-to-Cisco SIP IP Phone Call Waiting

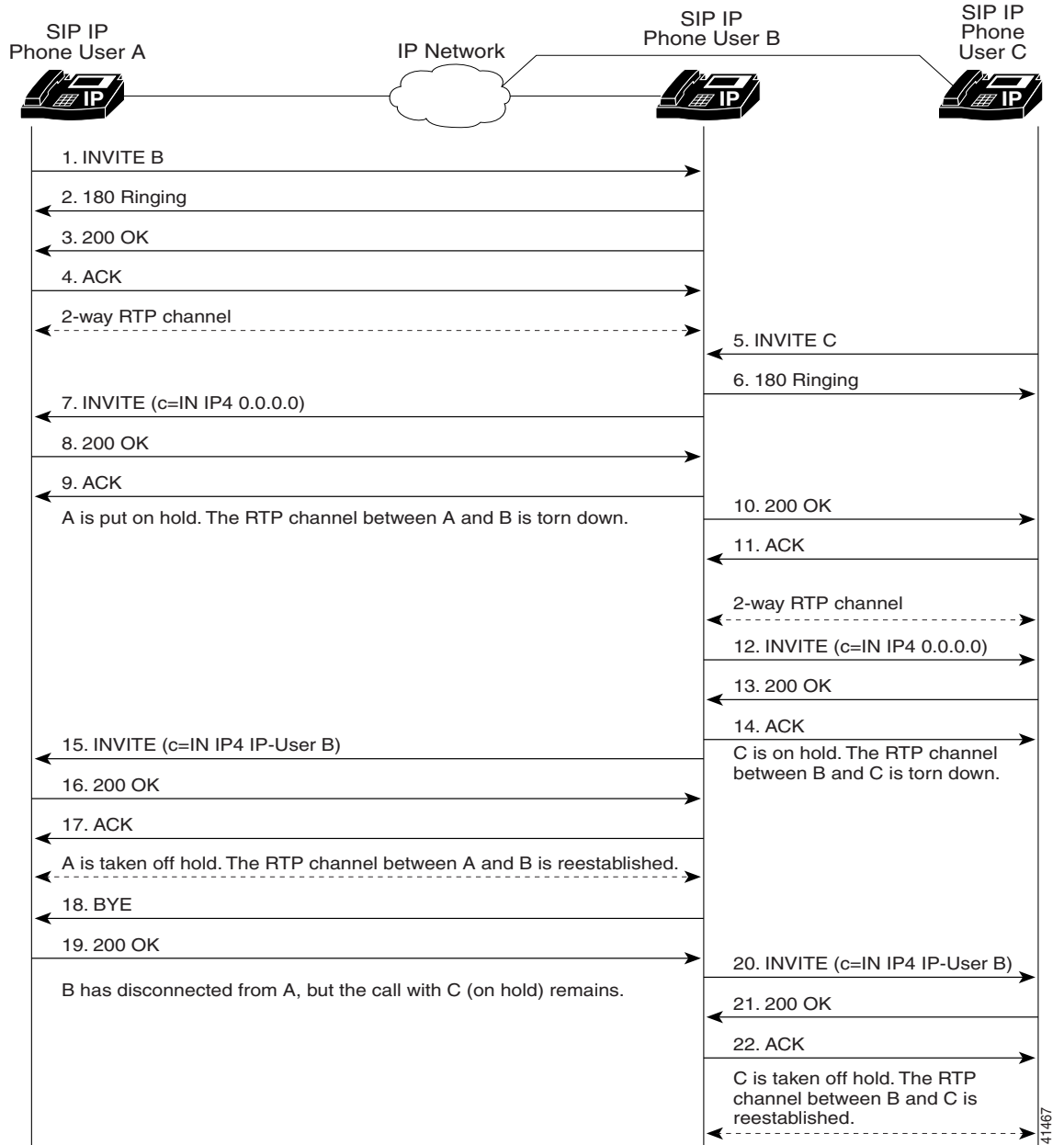

411467

Step	Action	Description
1.	INVITE—Cisco SIP IP phone A to Cisco SIP IP phone B	<p>Cisco SIP IP phone A sends a SIP INVITE request to Cisco SIP IP phone B. The INVITE request is an invitation to User B to participate in a call session.</p> <p>In the INVITE request:</p> <ul style="list-style-type: none"> <li>• The phone number of User B is inserted in the Request-URI field in the form of a SIP URL. The SIP URL identifies the address of User B and takes a form similar to an e-mail address (<i>user@host</i>, where <i>user</i> is the telephone number and <i>host</i> is either a domain name or a numeric network address). For example, the Request-URI field in the INVITE request to User B appears as “INVITE sip:555-0002@companyb.com; user=phone.” The “user=phone” parameter distinguishes that the Request-URI address is a telephone number rather than a username.</li> <li>• Cisco SIP IP phone A is identified as the call session initiator in the From field.</li> <li>• A unique numeric identifier is assigned to the call and is inserted in the Call-ID field.</li> <li>• The transaction number within a single call leg is identified in the CSeq field.</li> <li>• The media capability User A is ready to receive is specified.</li> </ul>
2.	180 Ringing—Cisco SIP IP phone B to Cisco SIP IP phone A	Cisco SIP IP phone B sends a SIP 180 Ringing response to Cisco SIP IP phone A.
3.	200 OK—Cisco SIP IP phone B to Cisco SIP IP phone A	<p>Cisco SIP IP phone B sends a SIP 200 OK response to Cisco SIP IP phone A. The 200 OK response notifies Cisco SIP IP phone A that the connection has been made.</p> <p>If Cisco SIP IP phone B supports the media capability advertised in the INVITE message sent by Cisco SIP IP phone A, it advertises the intersection of its own and Cisco SIP IP phone A’s media capability in the 200 OK response. If Cisco SIP IP phone B does not support the media capability advertised by Cisco SIP IP phone A, it sends back a 400 Bad Request response with a 304 Warning header field.</p>
4.	ACK—Cisco SIP IP phone A to Cisco SIP IP phone B	<p>Cisco SIP IP phone A sends a SIP ACK to Cisco SIP IP phone B. The ACK confirms that Cisco SIP IP phone A has received the 200 OK response from Cisco SIP IP phone B.</p> <p>The ACK might contain a message body with the final session description to be used by Cisco SIP IP phone B. If the message body of the ACK is empty, Cisco SIP IP phone B uses the session description in the INVITE request.</p>
A two-way RTP channel is established between Cisco SIP IP phone A and Cisco SIP IP phone B.		
5.	INVITE—Cisco SIP IP phone C to Cisco SIP IP phone B	Cisco SIP IP phone C sends a SIP INVITE request to Cisco SIP IP phone B. The INVITE request is an invitation to User B to participate in a call session.
6.	180 Ringing—Cisco SIP IP phone B to Cisco SIP IP phone C	Cisco SIP IP phone B sends a SIP 180 Ringing response to Cisco SIP IP phone C.

Step	Action	Description
7.	INVITE—Cisco SIP IP phone B to Cisco SIP IP phone A	<p>Cisco SIP IP phone B sends a mid-call INVITE to Cisco SIP IP phone A with new SDP session parameters (IP address), which are used to place the call on hold.</p> <pre>Call_ID=1 SDP: c=IN IP4 0.0.0.0</pre> <p>The c= SDP field of the SIP INVITE contains 0.0.0.0. This places the call in hold.</p>
8.	200 OK—Cisco SIP IP phone A to Cisco SIP IP phone B	Cisco SIP IP phone A sends a SIP 200 OK response to Cisco SIP IP phone B.
9.	ACK—Cisco SIP IP phone B to Cisco SIP IP phone A	Cisco SIP IP phone B sends a SIP ACK to Cisco SIP IP phone A. The ACK confirms that Cisco SIP IP phone B has received the 200 OK response from Cisco SIP IP phone A.

The RTP channel between Cisco SIP IP phone A and Cisco SIP IP phone B is torn down.

10.	200 OK—Cisco SIP IP phone B to Cisco SIP IP phone C	Cisco SIP IP phone B sends a SIP 200 OK response to Cisco SIP IP phone C. The 200 OK response notifies Cisco SIP IP phone C that the connection has been made.
11.	ACK—Cisco SIP IP phone C to Cisco SIP IP phone B	<p>Cisco SIP IP phone C sends a SIP ACK to Cisco SIP IP phone B. The ACK confirms that Cisco SIP IP phone C has received the 200 OK response from Cisco SIP IP phone B.</p> <p>The ACK might contain a message body with the final session description to be used by Cisco SIP IP phone B. If the message body of the ACK is empty, Cisco SIP IP phone B uses the session description in the INVITE request.</p>

A two-way RTP channel is established between Cisco SIP IP phone B and Cisco SIP IP phone C.

12.	INVITE—Cisco SIP IP phone B to Cisco SIP IP phone C	<p>Cisco SIP IP phone B sends a mid-call INVITE to Cisco SIP IP phone C with new SDP session parameters (IP address), which are used to place the call on hold.</p> <pre>Call_ID=2 SDP: c=IN IP4 0.0.0.0</pre> <p>To establish the call between phone B and phone C, the IP address of phone B is inserted into the c= SDP field.</p>
13.	200 OK—Cisco SIP IP phone C to Cisco SIP IP phone B	Cisco SIP IP phone C sends a SIP 200 OK response to Cisco SIP IP phone B.
14.	ACK—Cisco SIP IP phone B to Cisco SIP IP phone C	Cisco SIP IP phone B sends a SIP ACK to Cisco SIP IP phone C. The ACK confirms that Cisco SIP IP phone B has received the 200 OK response from Cisco SIP IP phone C.

The RTP channel between Cisco SIP IP phone B and Cisco SIP IP phone C is torn down.

15.	INVITE—Cisco SIP IP phone B to Cisco SIP IP phone A	<p>Cisco SIP IP phone B sends a mid-call INVITE to Cisco SIP IP phone A with the same call ID as the previous INVITE (sent to Cisco SIP IP phone A) and new SDP session parameters (IP address), which are used to reestablish the call.</p> <pre>Call_ID=1 SDP: c=IN IP4 181.23.250.2</pre>
16.	200 OK—Cisco SIP IP phone A to Cisco SIP IP phone B	Cisco SIP IP phone A sends a SIP 200 OK response to Cisco SIP IP phone B.

Step	Action	Description
17.	ACK—Cisco SIP IP phone B to Cisco SIP IP phone A	Cisco SIP IP phone B sends a SIP ACK to Cisco SIP IP phone A. The ACK confirms that Cisco SIP IP phone B has received the 200 OK response from Cisco SIP IP phone A.
A two-way RTP channel is reestablished between Cisco SIP IP phone A and Cisco SIP IP phone B.		
18.	BYE—Cisco SIP IP phone B to Cisco SIP IP phone A	The call continues and then User B hangs up. Cisco SIP IP phone B sends a SIP BYE request to Cisco SIP IP phone A. The BYE request indicates that User B wants to release the call.
19.	200 OK—Cisco SIP IP phone A to Cisco SIP IP phone B	Cisco SIP IP phone A sends a SIP 200 OK message to Cisco SIP IP phone B. The 200 OK response notifies Cisco SIP IP phone B that the BYE request has been received. The call session between User A and User B is now terminated.
The RTP channel between Cisco SIP IP phone A and Cisco SIP IP phone B is torn down.		
20.	INVITE—Cisco SIP IP phone B to Cisco SIP IP phone C	Cisco SIP IP phone B sends a mid-call INVITE to Cisco SIP IP phone C with the same call ID as the previous INVITE (sent to Cisco SIP IP phone C) and new SDP session parameters (IP address), which are used to reestablish the call.  Call_ID=2 SDP: c=IN IP4 181.23.250.2
21.	200 OK—Cisco SIP IP phone C to Cisco SIP IP phone B	Cisco SIP IP phone C sends a SIP 200 OK response to Cisco SIP IP phone B.
22.	ACK—Cisco SIP IP phone B to Cisco SIP IP phone C	Cisco SIP IP phone B sends a SIP ACK to Cisco SIP IP phone C. The ACK confirms that Cisco SIP IP phone B has received the 200 OK response from Cisco SIP IP phone A.
A two-way RTP channel is reestablished between Cisco SIP IP phone B and Cisco SIP IP phone C.		

## Cisco SIP IP Phone-to-Cisco SIP IP Phone Call Transfer Without Consultation

Figure B-6 illustrates a successful call between Cisco SIP IP phones in which two parties are in a call and then one of the participants transfers the call to a third party without first contacting the third party. This is called a blind or unattended transfer. In this call flow scenario, the end users are User A, User B, and User C. They are all using Cisco SIP IP phones, which are connected via an IP network.

The call flow scenario is as follows:

1. User A calls User B.
2. User B answers the call.
3. User B transfers the call to User C.

Figure B-6 Cisco SIP IP Phone-to-Cisco SIP IP Phone Call Transfer without Consultation

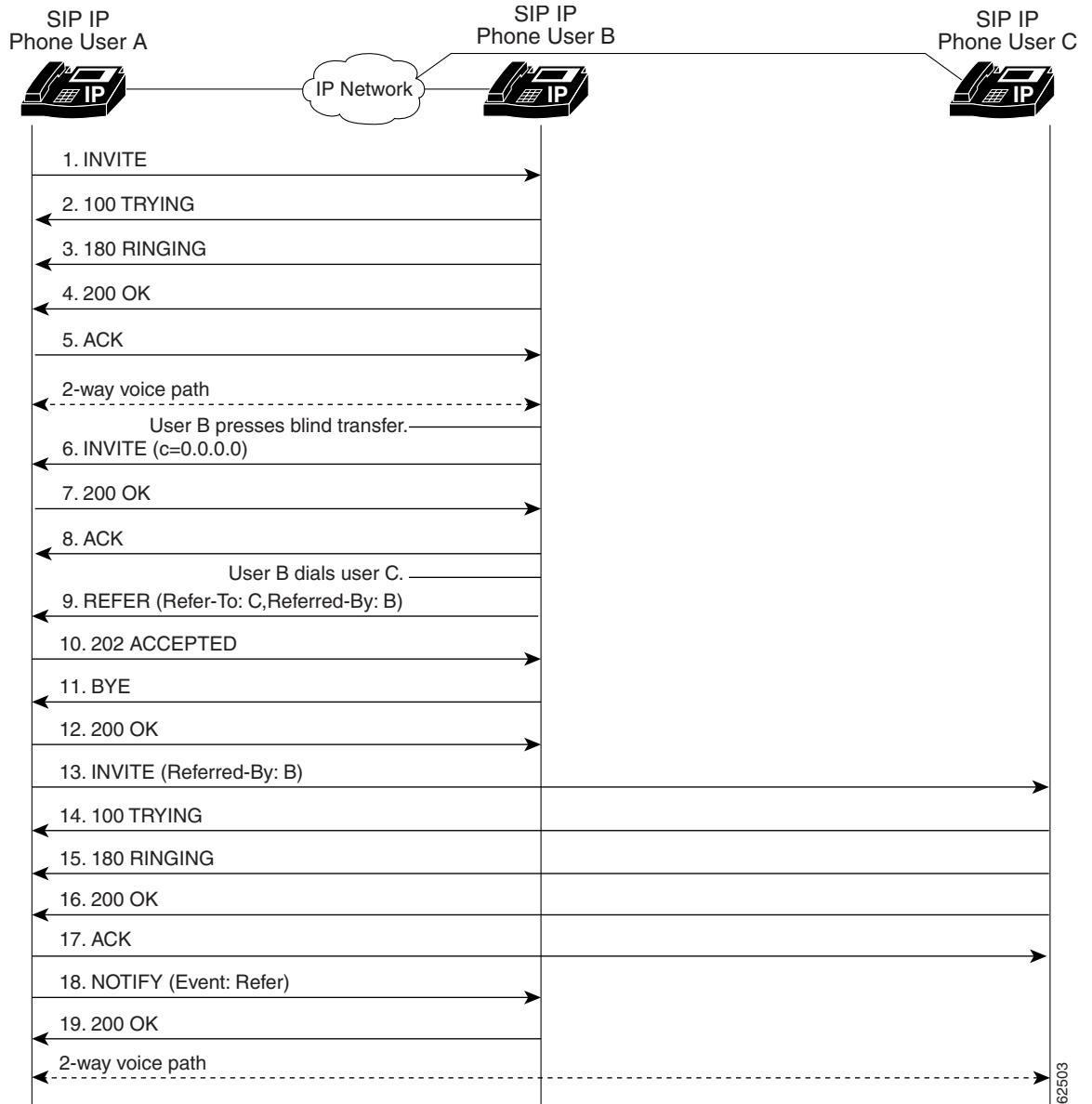

62503



Step	Action	Description
1.	INVITE—Cisco SIP IP phone A to Cisco SIP IP phone B	<p>Cisco SIP IP phone A sends a SIP INVITE request to Cisco SIP IP phone B. The INVITE request is an invitation to User B to participate in a call session.</p> <p>In the INVITE request:</p> <ul style="list-style-type: none"> <li>The phone number of User B is inserted in the Request-URI field in the form of a SIP URL. The SIP URL identifies the address of User B and takes a form similar to an e-mail address (<i>user@host</i>, where <i>user</i> is the telephone number and <i>host</i> is either a domain name or a numeric network address). For example, the Request-URI field in the INVITE request to User B appears as “INVITE sip:555-0002@companyb.com; user=phone.” The “user=phone” parameter distinguishes that the Request-URI address is a telephone number rather than a username.</li> <li>Cisco SIP IP phone A is identified as the call session initiator in the From field.</li> <li>A unique numeric identifier is assigned to the call and is inserted in the Call-ID field.</li> <li>The transaction number within a single call leg is identified in the CSeq field.</li> <li>The media capability User A is ready to receive is specified.</li> </ul>
2.	100 Trying—Cisco SIP IP phone B to Cisco SIP IP phone A	The Cisco SIP IP phone B sends a SIP 100 Trying response to Cisco SIP IP phone A. The 100 Trying response indicates that the INVITE request has been received by Cisco SIP IP phone B.
3.	180 Ringing—Cisco SIP IP phone B to Cisco SIP IP phone A	Cisco SIP IP phone B sends a SIP 180 Ringing response to Cisco SIP IP phone A.
4.	200 OK—Cisco SIP IP phone B to Cisco SIP IP phone A	<p>Cisco SIP IP phone B sends a SIP 200 OK response to Cisco SIP IP phone A. The 200 OK response notifies Cisco SIP IP phone A that the connection has been made.</p> <p>If Cisco SIP IP phone B supports the media capability advertised in the INVITE message sent by Cisco SIP IP phone A, it advertises the intersection of its own and Cisco SIP IP phone A’s media capability in the 200 OK response. If Cisco SIP IP phone B does not support the media capability advertised by Cisco SIP IP phone A, it sends back a 400 Bad Request response with a 304 Warning header field.</p>
5.	ACK—Cisco SIP IP phone A to Cisco SIP IP phone B	<p>Cisco SIP IP phone A sends a SIP ACK to Cisco SIP IP phone B. The ACK confirms that Cisco SIP IP phone A has received the 200 OK response from Cisco SIP IP phone B.</p> <p>The ACK might contain a message body with the final session description to be used by Cisco SIP IP phone B. If the message body of the ACK is empty, Cisco SIP IP phone B uses the session description in the INVITE request.</p>

A two-way RTP channel is established between Cisco SIP IP phone A and Cisco SIP IP phone B. User B then selects the option to blind transfer the call to User C.

Step	Action	Description
6.	INVITE—Cisco SIP IP phone B to Cisco SIP IP phone A	<p>Cisco SIP IP phone B sends a mid-call INVITE to Cisco SIP IP phone A with new SDP session parameters (IP address), which are used to place the call on hold.</p> <pre>Call_ID=1 SDP: c=IN IP4 0.0.0.0</pre> <p>The c= SDP field of the SIP INVITE contains an 0.0.0.0. This places the call in hold.</p>
7.	200 OK—Cisco SIP IP phone A to Cisco SIP IP phone B	Cisco SIP IP phone A sends a SIP 200 OK response to Cisco SIP IP phone B.
8.	ACK—Cisco SIP IP phone B to Cisco SIP IP phone A	Cisco SIP IP phone B sends a SIP ACK to Cisco SIP IP phone A. The ACK confirms that Cisco SIP IP phone B has received the 200 OK response from Cisco SIP IP phone A.
User B dials User C.		
9.	REFER—Cisco SIP IP phone B to Cisco SIP IP phone A	<p>Cisco SIP IP phone B sends a REFER message to Cisco SIP IP phone A. The REFER message contains the following information:</p> <ul style="list-style-type: none"> <li>• Refer-To: C</li> <li>• Referred-By: B</li> </ul> <p>The REFER message indicates that Cisco SIP IP phone A should send an INVITE request to Cisco SIP IP phone C.</p>
10.	202 ACCEPTED—Cisco SIP IP phone A to Cisco SIP IP phone B	Cisco SIP IP phone A sends a SIP 202 ACCEPTED message to Cisco SIP IP phone B. The 202 ACCEPTED confirms that the REFER message has been received.
11.	BYE—Cisco SIP IP phone B to Cisco SIP IP phone A	Cisco SIP IP phone B sends a BYE message to Cisco SIP IP phone A. This message indicates that Cisco SIP IP phone B will be disconnecting from the call.
12.	200 OK—Cisco SIP IP phone A to Cisco SIP IP phone B	Cisco SIP IP phone A sends a SIP 200 OK response to Cisco SIP IP phone B. The 200 OK response notifies Cisco SIP IP phone B that the BYE message was received.
13.	INVITE—Cisco SIP IP phone A to Cisco SIP IP phone C	<p>Because of the REFER message from Cisco SIP IP phone B, Cisco SIP IP phone A sends a SIP INVITE request to Cisco SIP IP phone C. The INVITE request is an invitation to User C to participate in a call session. The INVITE request contains the following information:</p> <ul style="list-style-type: none"> <li>• Referred-By: B</li> </ul> <p>This message indicates that the INVITE was referred by Cisco SIP IP phone B.</p>
14.	100 Trying—Cisco SIP IP phone C to Cisco SIP IP phone A	The Cisco SIP IP phone C sends a SIP 100 Trying response to Cisco SIP IP phone A. The 100 Trying response indicates that the INVITE request has been received by Cisco SIP IP phone C.
15.	180 Ringing—Cisco SIP IP phone C to Cisco SIP IP phone A	Cisco SIP IP phone C sends a SIP 180 Ringing response to Cisco SIP IP phone A.
16.	200 OK—Cisco SIP IP phone C to Cisco SIP IP phone A	Cisco SIP IP phone C sends a SIP 200 OK response to Cisco SIP IP phone A. The 200 OK response notifies Cisco SIP IP phone A that the connection has been made.
17.	ACK—Cisco SIP IP phone A to Cisco SIP IP phone C	Cisco SIP IP phone A sends a SIP ACK to Cisco SIP IP phone C. The ACK confirms that Cisco SIP IP phone A has received the 200 OK response from Cisco SIP IP phone C.

Step	Action	Description
18.	NOTIFY—Cisco SIP IP phone A to Cisco SIP IP phone B	Cisco SIP IP phone A sends a NOTIFY message to Cisco SIP IP phone B. The NOTIFY message notifies Cisco SIP IP phone C of the REFER event.
19.	200 OK—Cisco SIP IP phone B to Cisco SIP IP phone A	Cisco SIP IP phone B sends a SIP 200 OK response to Cisco SIP IP phone A. The 200 OK response notifies Cisco SIP IP phone A that the NOTIFY message was received.

A two-way RTP channel is established between Cisco SIP IP phone A and Cisco SIP IP phone C.

## Cisco SIP IP Phone-to-Cisco SIP IP Phone Call Transfer Without Consultation Using Failover to Bye/Also

Figure B-6 illustrates a successful call between Cisco SIP IP phones in which two parties are in a call and then one of the participants transfers the call to a third party without first contacting the third party. This is called a blind or unattended transfer. In this call flow scenario, the end users are User A, User B, and User C. They are all using Cisco SIP IP phones, which are connected via an IP network.

The call flow scenario is as follows:

1. User A calls User B.
2. User B answers the call.
3. User B transfers the call to User C.

**Figure B-7 Cisco SIP IP Phone-to-Cisco SIP IP Phone Call Transfer without Consultation Using Bye/Also**

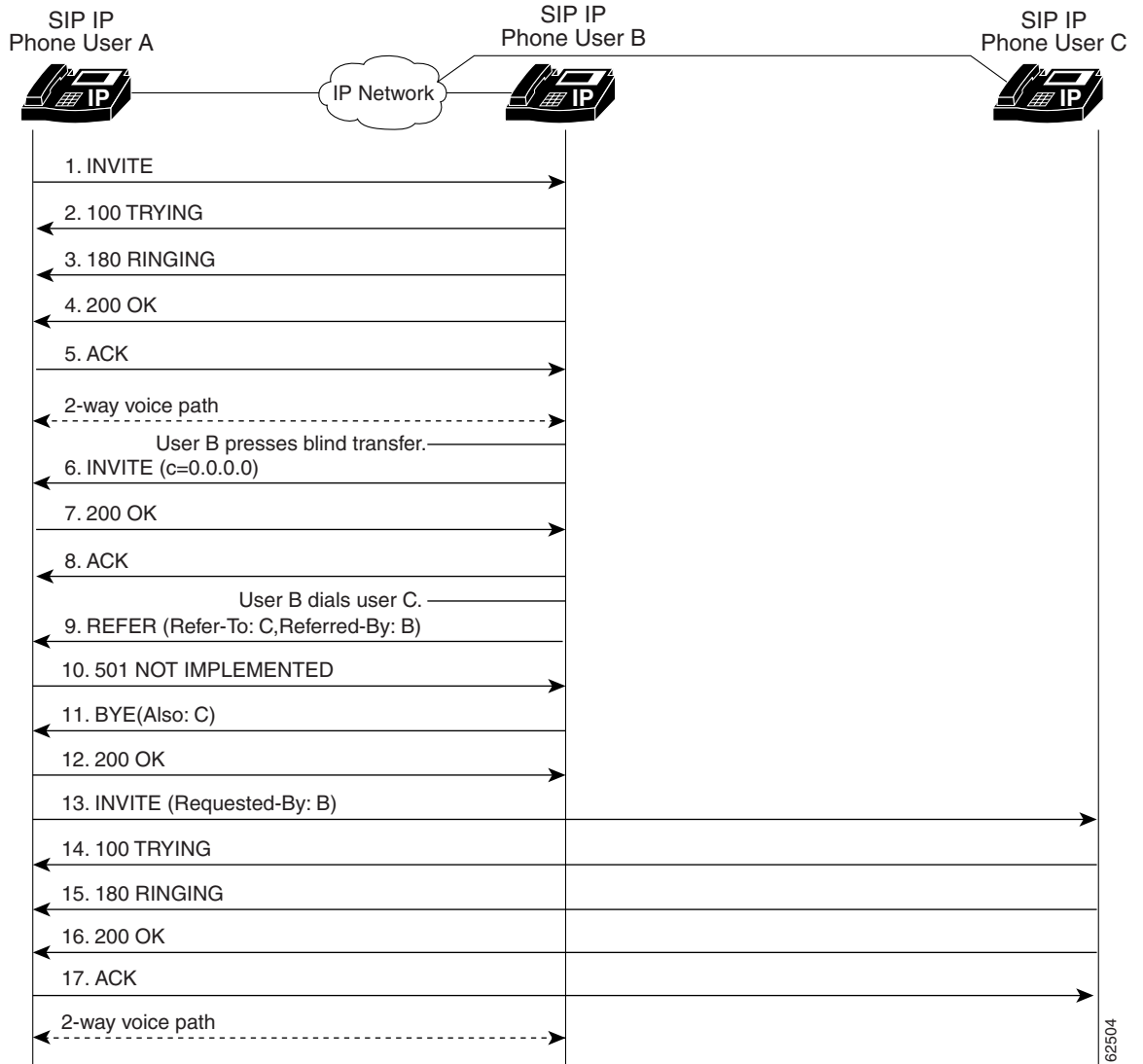

Step	Action	Description
1.	INVITE—Cisco SIP IP phone A to Cisco SIP IP phone B	<p>Cisco SIP IP phone A sends a SIP INVITE request to Cisco SIP IP phone B. The INVITE request is an invitation to User B to participate in a call session.</p> <p>In the INVITE request:</p> <ul style="list-style-type: none"> <li>• The phone number of User B is inserted in the Request-URI field in the form of a SIP URL. The SIP URL identifies the address of User B and takes a form similar to an e-mail address (<i>user@host</i>, where <i>user</i> is the telephone number and <i>host</i> is either a domain name or a numeric network address). For example, the Request-URI field in the INVITE request to User B appears as “INVITE sip:555-0002@companyb.com; user=phone.” The “user=phone” parameter distinguishes that the Request-URI address is a telephone number rather than a username.</li> <li>• Cisco SIP IP phone A is identified as the call session initiator in the From field.</li> <li>• A unique numeric identifier is assigned to the call and is inserted in the Call-ID field.</li> <li>• The transaction number within a single call leg is identified in the CSeq field.</li> <li>• The media capability User A is ready to receive is specified.</li> </ul>
2.	100 Trying—Cisco SIP IP phone B to Cisco SIP IP phone A	The Cisco SIP IP phone B sends a SIP 100 Trying response to Cisco SIP IP phone A. The 100 Trying response indicates that the INVITE request has been received by Cisco SIP IP phone B.
3.	180 Ringing—Cisco SIP IP phone B to Cisco SIP IP phone A	Cisco SIP IP phone B sends a SIP 180 Ringing response to Cisco SIP IP phone A.
4.	200 OK—Cisco SIP IP phone B to Cisco SIP IP phone A	<p>Cisco SIP IP phone B sends a SIP 200 OK response to Cisco SIP IP phone A. The 200 OK response notifies Cisco SIP IP phone A that the connection has been made.</p> <p>If Cisco SIP IP phone B supports the media capability advertised in the INVITE message sent by Cisco SIP IP phone A, it advertises the intersection of its own and Cisco SIP IP phone A’s media capability in the 200 OK response. If Cisco SIP IP phone B does not support the media capability advertised by Cisco SIP IP phone A, it sends back a 400 Bad Request response with a 304 Warning header field.</p>
5.	ACK—Cisco SIP IP phone A to Cisco SIP IP phone B	<p>Cisco SIP IP phone A sends a SIP ACK to Cisco SIP IP phone B. The ACK confirms that Cisco SIP IP phone A has received the 200 OK response from Cisco SIP IP phone B.</p> <p>The ACK might contain a message body with the final session description to be used by Cisco SIP IP phone B. If the message body of the ACK is empty, Cisco SIP IP phone B uses the session description in the INVITE request.</p>

A two-way RTP channel is established between Cisco SIP IP phone A and Cisco SIP IP phone B. User B then selects the option to blind transfer the call to User C.

Step	Action	Description
6.	INVITE—Cisco SIP IP phone B to Cisco SIP IP phone A	<p>Cisco SIP IP phone B sends a mid-call INVITE to Cisco SIP IP phone A with new SDP session parameters (IP address), which are used to place the call on hold.</p> <pre>Call_ID=1 SDP: c=IN IP4 0.0.0.0</pre> <p>The c= SDP field of the SIP INVITE contains an 0.0.0.0. This places the call in hold.</p>
7.	200 OK—Cisco SIP IP phone A to Cisco SIP IP phone B	Cisco SIP IP phone A sends a SIP 200 OK response to Cisco SIP IP phone B.
8.	ACK—Cisco SIP IP phone B to Cisco SIP IP phone A	Cisco SIP IP phone B sends a SIP ACK to Cisco SIP IP phone A. The ACK confirms that Cisco SIP IP phone B has received the 200 OK response from Cisco SIP IP phone A.

User B dials User C.

9.	REFER—Cisco SIP IP phone B to Cisco SIP IP phone A	<p>Cisco SIP IP phone B sends a REFER message to Cisco SIP IP phone A. The REFER message contains the following information:</p> <ul style="list-style-type: none"> <li>Refer-To: C</li> <li>Referred-By: B</li> </ul> <p>The REFER message indicates that Cisco SIP IP phone A should send an INVITE request to Cisco SIP IP phone C.</p>
10.	501 Not Implemented—Cisco SIP IP Phone A to Cisco SIP IP phone B	Cisco SIP IP phone A sends a 501 Not Implemented message to Cisco SIP IP phone B. This message indicates that the REFER message is not supported and that Cisco SIP IP phone B should failover to Bye/Also.
11.	BYE—Cisco SIP IP phone B to Cisco SIP IP phone A	<p>Cisco SIP IP phone B sends a BYE message to Cisco SIP IP phone A. The BYE message includes the following information:</p> <ul style="list-style-type: none"> <li>Also: C</li> </ul> <p>This message indicates that the 501 Not Implemented message was received in response to a REFER message.</p>
12.	200 OK—Cisco SIP IP phone A to Cisco SIP IP phone B	Cisco SIP IP phone A sends a SIP 200 OK response to Cisco SIP IP phone B. The 200 OK response notifies Cisco SIP IP phone B that the BYE message was received.
13.	INVITE—Cisco SIP IP phone A to Cisco SIP IP phone C	<p>Cisco SIP IP phone A sends a SIP INVITE request to Cisco SIP IP phone C. The INVITE request is an invitation to User C to participate in a call session. The INVITE request contains the following information:</p> <ul style="list-style-type: none"> <li>Requested-By: B</li> </ul> <p>This message indicates that the INVITE was requested by Cisco SIP IP phone B.</p>
14.	100 Trying—Cisco SIP IP phone C to Cisco SIP IP phone A	The Cisco SIP IP phone C sends a SIP 100 Trying response to Cisco SIP IP phone A. The 100 Trying response indicates that the INVITE request has been received by Cisco SIP IP phone C.
15.	180 Ringing—Cisco SIP IP phone C to Cisco SIP IP phone A	Cisco SIP IP phone C sends a SIP 180 Ringing response to Cisco SIP IP phone A.
16.	200 OK—Cisco SIP IP phone C to Cisco SIP IP phone A	Cisco SIP IP phone C sends a SIP 200 OK response to Cisco SIP IP phone A. The 200 OK response notifies Cisco SIP IP phone A that the connection has been made.

Step	Action	Description
17.	ACK—Cisco SIP IP phone A to Cisco SIP IP phone C	Cisco SIP IP phone A sends a SIP ACK to Cisco SIP IP phone C. The ACK confirms that Cisco SIP IP phone A has received the 200 OK response from Cisco SIP IP phone C.

A two-way RTP channel is established between Cisco SIP IP phone A and Cisco SIP IP phone C.

## Cisco SIP IP Phone-to-Cisco SIP IP Phone Call Transfer with Consultation

Figure B-8 illustrates a successful call between Cisco SIP IP phones in which two parties are in a call, one of the participants contacts a third party, and then that participant transfers the call to the third party. This is called an attended transfer. In this call flow scenario, the end users are User A, User B, and User C. They are all using Cisco SIP IP phones, which are connected via an IP network.

The call flow scenario is as follows:

1. User A calls User B.
2. User B answers the call.
3. User B calls User C, and User C consents to take the call.
4. User B transfers the call to User C.
5. User B disconnects with User C.
6. User C and User A connect to each other.

Figure B-8 Cisco SIP IP Phone-to-Cisco SIP IP Phone Call Transfer with Consultation

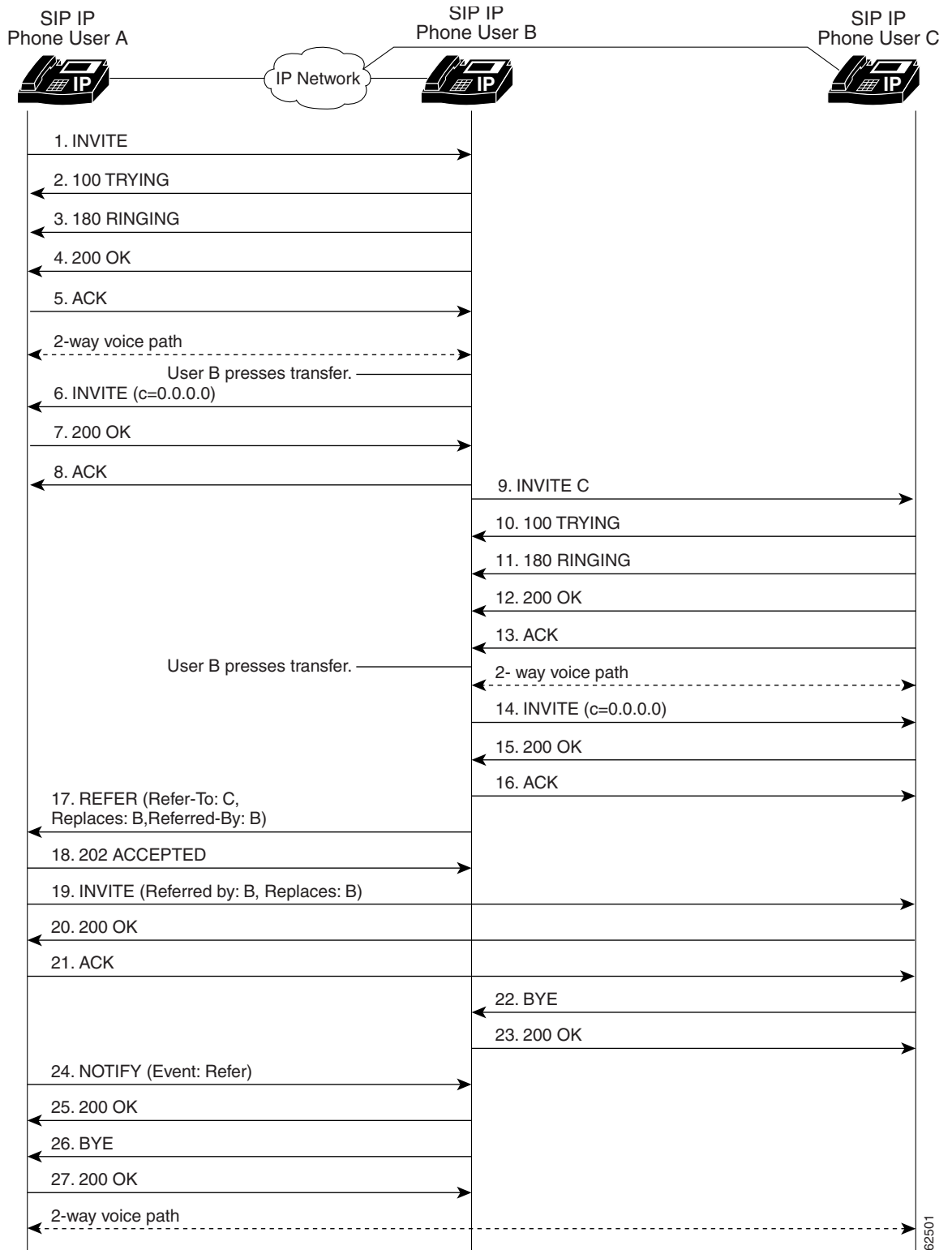



Step	Action	Description
1.	INVITE—Cisco SIP IP phone A to Cisco SIP IP phone B	<p>Cisco SIP IP phone A sends a SIP INVITE request to Cisco SIP IP phone B. The INVITE request is an invitation to User B to participate in a call session.</p> <p>In the INVITE request:</p> <ul style="list-style-type: none"> <li>The phone number of User B is inserted in the Request-URI field in the form of a SIP URL. The SIP URL identifies the address of User B and takes a form similar to an e-mail address (<i>user@host</i>, where <i>user</i> is the telephone number and <i>host</i> is either a domain name or a numeric network address). For example, the Request-URI field in the INVITE request to User B appears as “INVITE sip:555-0002@companyb.com; user=phone.” The “user=phone” parameter distinguishes that the Request-URI address is a telephone number rather than a username.</li> <li>Cisco SIP IP phone A is identified as the call session initiator in the From field.</li> <li>A unique numeric identifier is assigned to the call and is inserted in the Call-ID field.</li> <li>The transaction number within a single call leg is identified in the CSeq field.</li> <li>The media capability User A is ready to receive is specified.</li> </ul>
2.	100 Trying—Cisco SIP IP phone B to Cisco SIP IP phone A	The Cisco SIP IP phone B sends a SIP 100 Trying response to Cisco SIP IP phone A. The 100 Trying response indicates that the INVITE request has been received by Cisco SIP IP phone B.
3.	180 Ringing—Cisco SIP IP phone B to Cisco SIP IP phone A	Cisco SIP IP phone B sends a SIP 180 Ringing response to Cisco SIP IP phone A.
4.	200 OK—Cisco SIP IP phone B to Cisco SIP IP phone A	<p>Cisco SIP IP phone B sends a SIP 200 OK response to Cisco SIP IP phone A. The 200 OK response notifies Cisco SIP IP phone A that the connection has been made.</p> <p>If Cisco SIP IP phone B supports the media capability advertised in the INVITE message sent by Cisco SIP IP phone A, it advertises the intersection of its own and Cisco SIP IP phone A’s media capability in the 200 OK response. If Cisco SIP IP phone B does not support the media capability advertised by Cisco SIP IP phone A, it sends back a 400 Bad Request response with a 304 Warning header field.</p>
5.	ACK—Cisco SIP IP phone A to Cisco SIP IP phone B	<p>Cisco SIP IP phone A sends a SIP ACK to Cisco SIP IP phone B. The ACK confirms that Cisco SIP IP phone A has received the 200 OK response from Cisco SIP IP phone B.</p> <p>The ACK might contain a message body with the final session description to be used by Cisco SIP IP phone B. If the message body of the ACK is empty, Cisco SIP IP phone B uses the session description in the INVITE request.</p>
<p>A two-way RTP channel is established between Cisco SIP IP phone A and Cisco SIP IP phone B. User B then selects the option to transfer the call to User C.</p>		
6.	INVITE—Cisco SIP IP phone B to Cisco SIP IP phone A	<p>Cisco SIP IP phone B sends a mid-call INVITE to Cisco SIP IP phone A with new SDP session parameters (IP address), which are used to place the call on hold.</p> <pre>Call_ID=1 SDP: c=IN IP4 0.0.0.0</pre>

Step	Action	Description
7.	200 OK—Cisco SIP IP phone A to Cisco SIP IP phone B	Cisco SIP IP phone A sends a SIP 200 OK response to Cisco SIP IP phone B.
8.	ACK—Cisco SIP IP phone B to Cisco SIP IP phone A	Cisco SIP IP phone B sends a SIP ACK to Cisco SIP IP phone A. The ACK confirms that Cisco SIP IP phone B has received the 200 OK response from Cisco SIP IP phone A.
User B dials User C.		
9.	INVITE—Cisco SIP IP phone B to Cisco SIP IP phone C	Cisco SIP IP phone B sends a SIP INVITE request to Cisco SIP IP phone C. The INVITE request is an invitation to User C to participate in a call session.
10.	100 Trying—Cisco SIP IP phone C to Cisco SIP IP phone B	The Cisco SIP IP phone C sends a SIP 100 Trying response to Cisco SIP IP phone B. The 100 Trying response indicates that the INVITE request has been received by Cisco SIP IP phone C.
11.	180 Ringing—Cisco SIP IP phone C to Cisco SIP IP phone B	Cisco SIP IP phone C sends a SIP 180 Ringing response to Cisco SIP IP phone B.
12.	200 OK—Cisco SIP IP phone C to Cisco SIP IP phone B	Cisco SIP IP phone C sends a SIP 200 OK response to Cisco SIP IP phone B. The 200 OK response notifies Cisco SIP IP phone B that the connection has been made.  If Cisco SIP IP phone B supports the media capability advertised in the INVITE message sent by Cisco SIP IP phone A, it advertises the intersection of its own and Cisco SIP IP phone A's media capability in the 200 OK response. If Cisco SIP IP phone B does not support the media capability advertised by Cisco SIP IP phone A, it sends back a 400 Bad Request response with a 304 Warning header field.
13.	ACK—Cisco SIP IP phone B to Cisco SIP IP phone C	Cisco SIP IP phone B sends a SIP ACK to Cisco SIP IP phone C. The ACK confirms that Cisco SIP IP phone B has received the 200 OK response from Cisco SIP IP phone C.  The ACK might contain a message body with the final session description to be used by Cisco SIP IP phone C. If the message body of the ACK is empty, Cisco SIP IP phone C uses the session description in the INVITE request.
A two-way RTP channel is established between Cisco SIP IP phone B and Cisco SIP IP phone C. User B then selects the option to transfer the call to User C.		
14.	INVITE—Cisco SIP IP phone B to Cisco SIP IP phone A	Cisco SIP IP phone B sends a mid-call INVITE to Cisco SIP IP phone A with new SDP session parameters (IP address), which are used to place the call on hold.  <code>Call_ID=1</code> <code>SDP: c=IN IP4 0.0.0.0</code>  The c= SDP field of the SIP INVITE contains an 0.0.0.0. This places the call in hold.
15.	200 OK—Cisco SIP IP phone A to Cisco SIP IP phone B	Cisco SIP IP phone A sends a SIP 200 OK response to Cisco SIP IP phone B.
16.	ACK—Cisco SIP IP phone B to Cisco SIP IP phone C	Cisco SIP IP phone B sends a SIP ACK to Cisco SIP IP phone C. The ACK confirms that Cisco SIP IP phone B has received the 200 OK response from Cisco SIP IP phone C.

Step	Action	Description
17.	REFER—Cisco SIP IP phone B to Cisco SIP IP phone A	<p>Cisco SIP IP phone B sends a REFER message to Cisco SIP IP phone A. The REFER message contains the following information:</p> <ul style="list-style-type: none"> <li>• Refer-To: C</li> <li>• Replaces: B</li> <li>• Referred-By: B</li> </ul> <p>The REFER message indicates that the user (recipient) should contact a third party for use in transferring parties.</p>
18.	202 ACCEPTED—Cisco SIP IP phone A to Cisco SIP IP phone B	Cisco SIP IP phone A sends a SIP 202 ACCEPTED message to Cisco SIP IP phone B. The 202 ACCEPTED confirms that the REFER message has been received.
19.	INVITE—Cisco SIP IP phone A to Cisco SIP IP phone C	<p>Cisco SIP IP phone A sends a SIP INVITE request to Cisco SIP IP phone C. The INVITE request contains the following information:</p> <ul style="list-style-type: none"> <li>• Referred-By: B</li> <li>• Replaces: B</li> </ul>
20.	200 OK—Cisco SIP IP phone C to Cisco SIP IP phone A	Cisco SIP IP phone C sends a SIP 200 OK message to Cisco SIP IP phone A. The 200 OK response notifies Cisco SIP IP phone A that the INVITE request has been received.
21.	ACK—Cisco SIP IP phone A to Cisco SIP IP phone C	Cisco SIP IP phone A sends a SIP ACK to Cisco SIP IP phone C. The ACK confirms that Cisco SIP IP phone A has received the 200 OK response from Cisco SIP IP phone C.
22.	BYE—Cisco SIP IP phone C to Cisco SIP IP phone B	Cisco SIP IP phone C sends a SIP BYE request to Cisco SIP IP phone B.
23.	200 OK—Cisco SIP IP phone B to Cisco SIP IP phone C	Cisco SIP IP phone B sends a SIP 200 OK message to Cisco SIP IP phone C. The 200 OK response notifies Cisco SIP IP phone C that the BYE request has been received.
24.	NOTIFY—Cisco SIP IP phone A to Cisco SIP IP phone B	Cisco SIP IP phone A sends a NOTIFY message to Cisco SIP IP phone B. The NOTIFY message notifies Cisco SIP IP phone B of the REFER event.
25.	200 OK—Cisco SIP IP phone B to Cisco SIP IP phone A	Cisco SIP IP phone B sends a SIP 200 OK message to Cisco SIP IP phone A. The 200 OK response notifies Cisco SIP IP phone A that the NOTIFY request has been received.
26.	BYE—Cisco SIP IP phone B to Cisco SIP IP phone A	Cisco SIP IP phone B sends a SIP BYE request to Cisco SIP IP phone A.
27.	200 OK—Cisco SIP IP phone A to Cisco SIP IP phone B	Cisco SIP IP phone A sends a SIP 200 OK message to Cisco SIP IP phone B. The 200 OK response notifies Cisco SIP IP phone A that the BYE request has been received.

A two-way RTP channel is established between Cisco SIP IP phone A and Cisco SIP IP phone C.

## Cisco SIP IP Phone-to-Cisco SIP IP Phone Call Transfer with Consultation Using Failover to Bye/Also

Figure B-9 illustrates a successful call between Cisco SIP IP phones in which two parties are in a call, one of the participants contacts a third party, and then that participant transfers the call to the third party. This is called an attended transfer. In this call flow scenario, the end users are User A, User B, and User C. They are all using Cisco SIP IP phones, which are connected via an IP network.

The call flow scenario is as follows:

1. User A calls User B.
2. User B answers the call.
3. User B calls User C, and User C consents to take the call.
4. User B transfers the call to User C.
5. User B disconnects with User C.
6. User C and User A connect to each other.

**Figure B-9 Cisco SIP IP Phone-to-Cisco SIP IP Phone Call Transfer with Consultation Using Failover to Bye/Also**

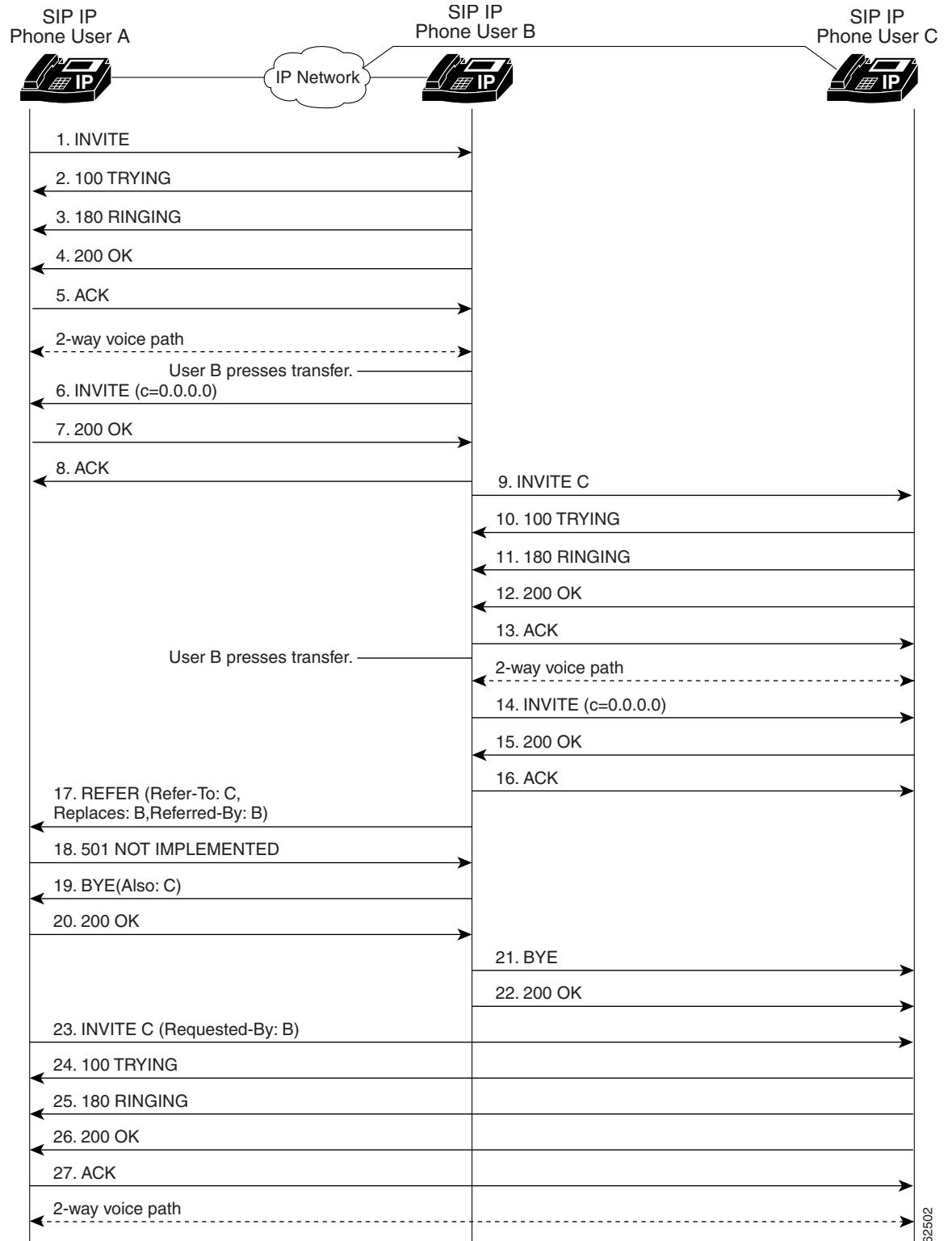

62502

Step	Action	Description
1.	INVITE—Cisco SIP IP phone A to Cisco SIP IP phone B	<p>Cisco SIP IP phone A sends a SIP INVITE request to Cisco SIP IP phone B. The INVITE request is an invitation to User B to participate in a call session.</p> <p>In the INVITE request:</p> <ul style="list-style-type: none"> <li>The phone number of User B is inserted in the Request-URI field in the form of a SIP URL. The SIP URL identifies the address of User B and takes a form similar to an e-mail address (<i>user@host</i>, where <i>user</i> is the telephone number and <i>host</i> is either a domain name or a numeric network address). For example, the Request-URI field in the INVITE request to User B appears as “INVITE sip:555-0002@companyb.com; user=phone.” The “user=phone” parameter distinguishes that the Request-URI address is a telephone number rather than a username.</li> <li>Cisco SIP IP phone A is identified as the call session initiator in the From field.</li> <li>A unique numeric identifier is assigned to the call and is inserted in the Call-ID field.</li> <li>The transaction number within a single call leg is identified in the CSeq field.</li> <li>The media capability User A is ready to receive is specified.</li> </ul>
2.	100 Trying—Cisco SIP IP phone B to Cisco SIP IP phone A	The Cisco SIP IP phone B sends a SIP 100 Trying response to Cisco SIP IP phone A. The 100 Trying response indicates that the INVITE request has been received by Cisco SIP IP phone B.
3.	180 Ringing—Cisco SIP IP phone B to Cisco SIP IP phone A	Cisco SIP IP phone B sends a SIP 180 Ringing response to Cisco SIP IP phone A.
4.	200 OK—Cisco SIP IP phone B to Cisco SIP IP phone A	<p>Cisco SIP IP phone B sends a SIP 200 OK response to Cisco SIP IP phone A. The 200 OK response notifies Cisco SIP IP phone A that the connection has been made.</p> <p>If Cisco SIP IP phone B supports the media capability advertised in the INVITE message sent by Cisco SIP IP phone A, it advertises the intersection of its own and Cisco SIP IP phone A’s media capability in the 200 OK response. If Cisco SIP IP phone B does not support the media capability advertised by Cisco SIP IP phone A, it sends back a 400 Bad Request response with a 304 Warning header field.</p>
5.	ACK—Cisco SIP IP phone A to Cisco SIP IP phone B	<p>Cisco SIP IP phone A sends a SIP ACK to Cisco SIP IP phone B. The ACK confirms that Cisco SIP IP phone A has received the 200 OK response from Cisco SIP IP phone B.</p> <p>The ACK might contain a message body with the final session description to be used by Cisco SIP IP phone B. If the message body of the ACK is empty, Cisco SIP IP phone B uses the session description in the INVITE request.</p>
A two-way RTP channel is established between Cisco SIP IP phone A and Cisco SIP IP phone B. User B then selects the option to transfer the call to User C.		
6.	INVITE—Cisco SIP IP phone B to Cisco SIP IP phone A	<p>Cisco SIP IP phone B sends a mid-call INVITE to Cisco SIP IP phone A with new SDP session parameters (IP address), which are used to place the call on hold.</p> <pre>Call_ID=1 SDP: c=IN IP4 0.0.0.0</pre>

Step	Action	Description
7.	200 OK—Cisco SIP IP phone A to Cisco SIP IP phone B	Cisco SIP IP phone A sends a SIP 200 OK response to Cisco SIP IP phone B.
8.	ACK—Cisco SIP IP phone B to Cisco SIP IP phone A	Cisco SIP IP phone B sends a SIP ACK to Cisco SIP IP phone A. The ACK confirms that Cisco SIP IP phone B has received the 200 OK response from Cisco SIP IP phone A.
User B dials User C.		
9.	INVITE—Cisco SIP IP phone B to Cisco SIP IP phone C	Cisco SIP IP phone B sends a SIP INVITE request to Cisco SIP IP phone C. The INVITE request is an invitation to User C to participate in a call session.
10.	100 Trying—Cisco SIP IP phone C to Cisco SIP IP phone B	The Cisco SIP IP phone C sends a SIP 100 Trying response to Cisco SIP IP phone B. The 100 Trying response indicates that the INVITE request has been received by the Cisco SIP IP phone.
11.	180 Ringing—Cisco SIP IP phone C to Cisco SIP IP phone B	Cisco SIP IP phone C sends a SIP 180 Ringing response to Cisco SIP IP phone B.
12.	200 OK—Cisco SIP IP phone C to Cisco SIP IP phone B	Cisco SIP IP phone C sends a SIP 200 OK response to Cisco SIP IP phone B. The 200 OK response notifies Cisco SIP IP phone B that the connection has been made.  If Cisco SIP IP phone B supports the media capability advertised in the INVITE message sent by Cisco SIP IP phone A, it advertises the intersection of its own and Cisco SIP IP phone A's media capability in the 200 OK response. If Cisco SIP IP phone B does not support the media capability advertised by Cisco SIP IP phone A, it sends back a 400 Bad Request response with a 304 Warning header field.
13.	ACK—Cisco SIP IP phone B to Cisco SIP IP phone C	Cisco SIP IP phone B sends a SIP ACK to Cisco SIP IP phone C. The ACK confirms that Cisco SIP IP phone B has received the 200 OK response from Cisco SIP IP phone C.  The ACK might contain a message body with the final session description to be used by Cisco SIP IP phone C. If the message body of the ACK is empty, Cisco SIP IP phone C uses the session description in the INVITE request.
A two-way RTP channel is established between Cisco SIP IP phone B and Cisco SIP IP phone C. User B then selects the option to transfer the call to User C.		
14.	INVITE—Cisco SIP IP phone B to Cisco SIP IP phone A	Cisco SIP IP phone B sends a mid-call INVITE to Cisco SIP IP phone A with new SDP session parameters (IP address), which are used to place the call on hold.  <code>call_ID=1</code> <code>SDP: c=IN IP4 0.0.0.0</code>  The c= SDP field of the SIP INVITE contains an 0.0.0.0. This places the call in hold.
15.	200 OK—Cisco SIP IP phone A to Cisco SIP IP phone B	Cisco SIP IP phone A sends a SIP 200 OK response to Cisco SIP IP phone B.
16.	ACK—Cisco SIP IP phone B to Cisco SIP IP phone C	Cisco SIP IP phone B sends a SIP ACK to Cisco SIP IP phone C. The ACK confirms that Cisco SIP IP phone B has received the 200 OK response from Cisco SIP IP phone C.

Step	Action	Description
17.	REFER—Cisco SIP IP phone B to Cisco SIP IP phone A	<p>Cisco SIP IP phone B sends a REFER message to Cisco SIP IP phone A. The REFER message contains the following information:</p> <ul style="list-style-type: none"> <li>• Refer-To: C</li> <li>• Replaces: B</li> <li>• Referred-By: B</li> </ul> <p>The REFER message indicates that the user (recipient) should contact a third party for use in transferring parties.</p>
18.	501 Not Implemented—Cisco SIP IP Phone A to Cisco SIP IP Phone B	<p>Cisco SIP IP phone A sends a 501 Not Implemented message to Cisco SIP IP phone B. This message indicates that the REFER message is not supported and that Cisco SIP IP phone B should failover to Bye/Also.</p>
19.	BYE—Cisco SIP IP phone B to Cisco SIP IP phone A	<p>Cisco SIP IP phone B sends a BYE message to Cisco SIP IP phone A. The BYE message includes the following information:</p> <ul style="list-style-type: none"> <li>• Also: C</li> </ul> <p>This message indicates that the 501 Not Implemented message was received in response to a REFER message.</p>
20.	200 OK—Cisco SIP IP phone A to Cisco SIP IP phone B	<p>Cisco SIP IP phone A sends a SIP 200 OK message to Cisco SIP IP phone B. The 200 OK response notifies Cisco SIP IP phone B that the BYE request has been received.</p>
21.	BYE—Cisco SIP IP phone B to Cisco SIP IP phone C	<p>Cisco SIP IP phone B sends a SIP BYE request to Cisco SIP IP phone C.</p>
22.	200 OK—Cisco SIP IP phone C to Cisco SIP IP phone B	<p>Cisco SIP IP phone C sends a SIP 200 OK message to Cisco SIP IP phone B. The 200 OK response notifies Cisco SIP IP phone B that the BYE request has been received.</p>
23.	INVITE—Cisco SIP IP phone A to Cisco SIP IP phone C	<p>Cisco SIP IP phone A sends a SIP INVITE request to Cisco SIP IP phone C. The INVITE request contains the following information:</p> <ul style="list-style-type: none"> <li>• Requested-By: B</li> </ul> <p>This message indicates that the INVITE was requested by Cisco SIP IP phone B.</p>
24.	100 Trying—Cisco SIP IP phone C to Cisco SIP IP phone A	<p>The Cisco SIP IP phone C sends a SIP 100 Trying response to Cisco SIP IP phone A. The 100 Trying response indicates that the INVITE request has been received by Cisco SIP IP phone C.</p>
25.	180 Ringing—Cisco SIP IP phone C to Cisco SIP IP phone A	<p>Cisco SIP IP phone C sends a SIP 180 Ringing response to Cisco SIP IP phone A.</p>
26.	200 OK—Cisco SIP IP phone C to Cisco SIP IP phone A	<p>Cisco SIP IP phone C sends a SIP 200 OK response to Cisco SIP IP phone A. The 200 OK response notifies Cisco SIP IP phone A that the connection has been made.</p>
27.	ACK—Cisco SIP IP phone A to Cisco SIP IP phone C	<p>Cisco SIP IP phone A sends a SIP ACK to Cisco SIP IP phone C. The ACK confirms that Cisco SIP IP phone A has received the 200 OK response from Cisco SIP IP phone C.</p>

A two-way RTP channel is established between Cisco SIP IP phone A and Cisco SIP IP phone C.



## Cisco SIP IP Phone-to-Cisco SIP IP Phone Network Call Forwarding (Unconditional)

Figure B-10 illustrates successful call forwarding between Cisco SIP IP phones in which User B has requested unconditional call forwarding from the network. When User A calls User B, the call is immediately transferred to Cisco SIP IP phone C. In this call flow scenario, the end users are User A, User B, and User C. They are all using Cisco SIP IP phones, which are connected via an IP network.

The call flow scenario is as follows:

1. User B requests that the network forward all calls to Cisco SIP IP phone C.
2. User A calls User B.
3. The network transfers the call to Cisco SIP IP phone C.

**Figure B-10 Cisco SIP IP Phone-to-Cisco SIP IP Phone Network Call Forwarding (Unconditional)**

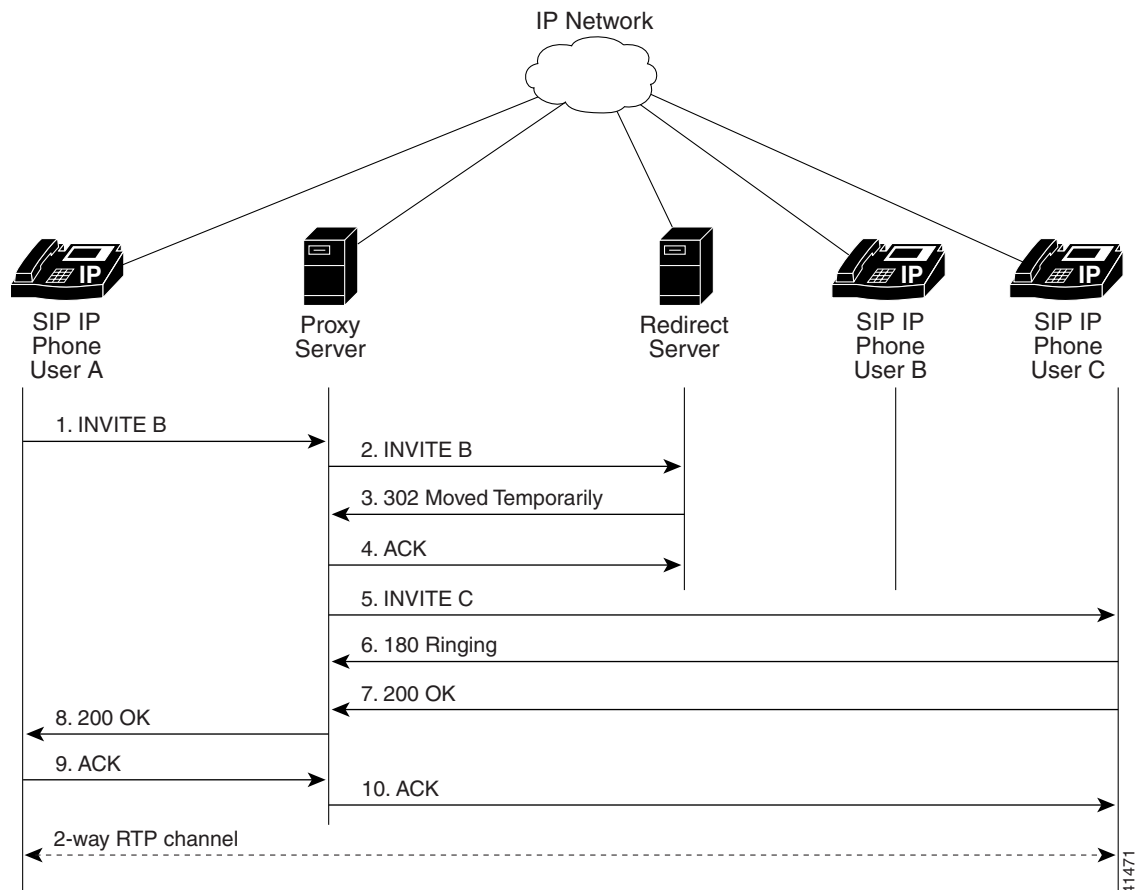

Step	Action	Description
1.	INVITE—Cisco SIP IP phone A to SIP proxy server	<p>Cisco SIP IP phone A sends a SIP INVITE request to the SIP proxy server. The INVITE request is an invitation to User B to participate in a call session.</p> <p>In the INVITE request:</p> <ul style="list-style-type: none"> <li>• The phone number of User B is inserted in the Request-URI field in the form of a SIP URL. The SIP URL identifies the address of User B and takes a form similar to an e-mail address (<i>user@host</i>, where <i>user</i> is the telephone number and <i>host</i> is either a domain name or a numeric network address). For example, the Request-URI field in the INVITE request to User B appears as “INVITE sip:555-0002@companyb.com; user=phone.” The “user=phone” parameter distinguishes that the Request-URI address is a telephone number rather than a username.</li> <li>• Cisco SIP IP phone A is identified as the call session initiator in the From field.</li> <li>• A unique numeric identifier is assigned to the call and is inserted in the Call-ID field.</li> <li>• The transaction number within a single call leg is identified in the CSeq field.</li> <li>• The media capability User A is ready to receive is specified.</li> </ul>
2.	INVITE—SIP proxy server to SIP redirect server	SIP proxy server sends the SIP INVITE request to the SIP redirect server.
3.	302 Moved Temporarily—SIP redirect server to SIP proxy server	SIP redirect server sends a SIP 302 Moved temporarily message to the SIP proxy server. The message indicates that User B is not available at SIP phone B and includes instructions to locate User B at Cisco SIP IP phone C.
4.	INVITE—SIP proxy server to Cisco SIP IP phone C	SIP proxy server sends a SIP INVITE request to Cisco SIP IP phone C. The INVITE request is an invitation to User C to participate in a call session.
5.	180 Ringing—Cisco SIP IP phone C to SIP proxy server	Cisco SIP IP phone C sends a SIP 180 Ringing response to the SIP proxy server.
6.	200 OK—Cisco SIP IP phone C to SIP proxy server	Cisco SIP IP phone C sends a SIP 200 OK response to the SIP proxy server.
7.	200 OK—SIP proxy server to Cisco SIP IP phone A	SIP proxy server forwards the SIP 200 OK response to Cisco SIP IP phone A.
8.	ACK—Cisco SIP IP phone A to SIP proxy server	Cisco SIP IP phone A sends a SIP ACK to the SIP proxy server. The ACK confirms that the SIP proxy server has received the 200 OK response from Cisco SIP IP phone C.
9.	ACK—SIP proxy server to Cisco SIP IP phone C	SIP proxy server forwards the SIP ACK to the Cisco SIP IP phone C. The ACK confirms that Cisco SIP IP phone A has received the 200 OK response from Cisco SIP IP phone C.

## Cisco SIP IP Phone-to-Cisco SIP IP Phone Network Call Forwarding (Busy)

Figure B-11 illustrates successful call forwarding between Cisco SIP IP phones in which User B has requested call forwarding from the network in the event the phone is busy. When User A calls User B, the SIP proxy server tries to place the call to Cisco SIP IP phone B and, if the line is busy, the call is transferred to Cisco SIP IP phone C. In this call flow scenario, the end users are User A, User B, and User C. They are all using Cisco SIP IP phones, which are connected via an IP network.

The call flow scenario is as follows:

1. User B requests that if their phone (Cisco SIP IP phone B) is busy, the network should forward incoming calls to Cisco SIP IP phone C.
2. User A calls User B.
3. User B's phone is busy.
4. The network transfers the call to Cisco SIP IP phone C.

**Figure B-11 Cisco SIP IP Phone-to-Cisco SIP IP Phone Network Call Forwarding (Busy)**

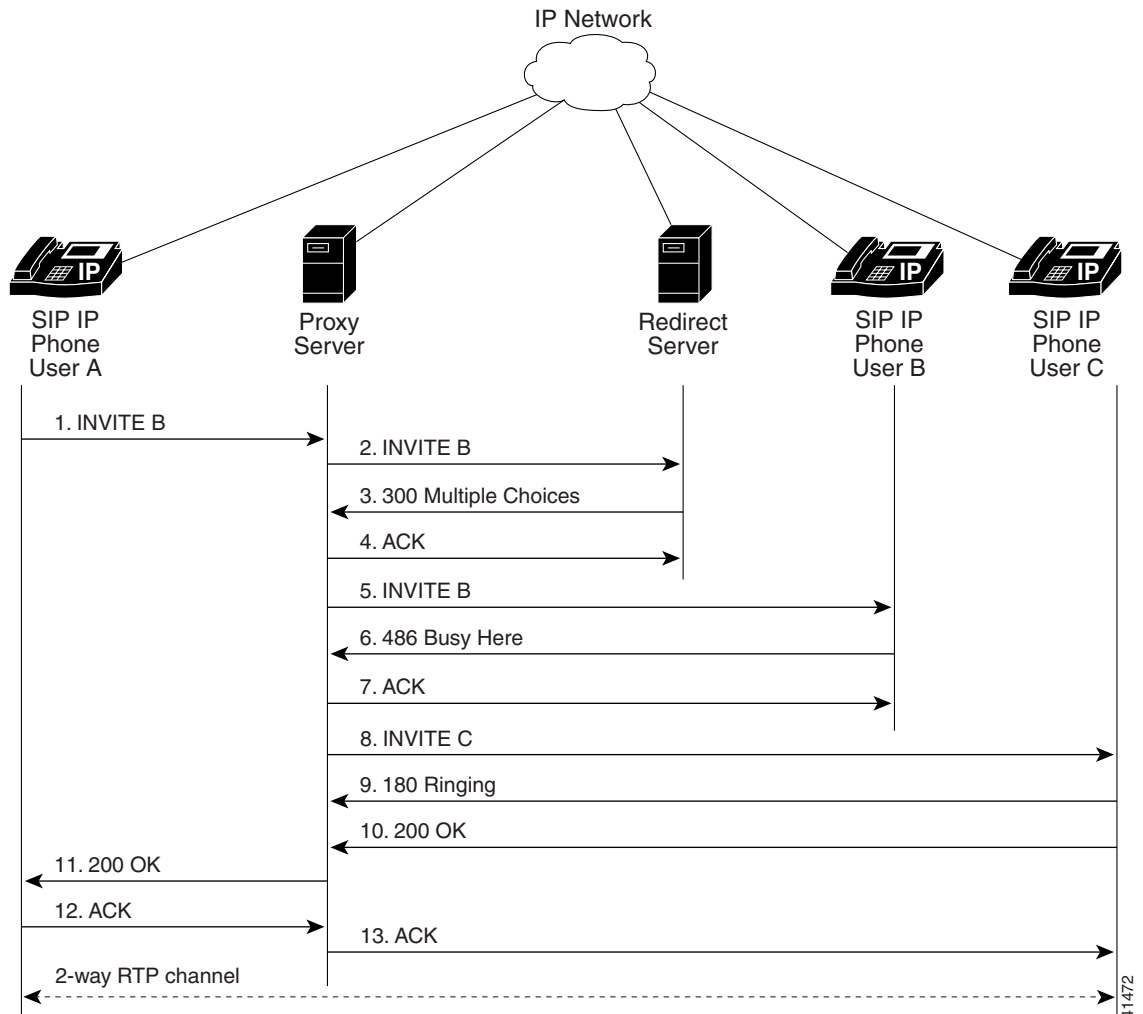

Step	Action	Description
1.	INVITE—Cisco SIP IP phone A to SIP proxy server	<p>Cisco SIP IP phone A sends a SIP INVITE request to the SIP proxy server. The INVITE request is an invitation to User B to participate in a call session.</p> <p>In the INVITE request:</p> <ul style="list-style-type: none"> <li>The phone number of User B is inserted in the Request-URI field in the form of a SIP URL. The SIP URL identifies the address of User B and takes a form similar to an e-mail address (<i>user@host</i>, where <i>user</i> is the telephone number and <i>host</i> is either a domain name or a numeric network address). For example, the Request-URI field in the INVITE request to User B appears as “INVITE sip:555-0002@companyb.com; user=phone.” The “user=phone” parameter distinguishes that the Request-URI address is a telephone number rather than a username.</li> <li>Cisco SIP IP phone A is identified as the call session initiator in the From field.</li> <li>A unique numeric identifier is assigned to the call and is inserted in the Call-ID field.</li> <li>The transaction number within a single call leg is identified in the CSeq field.</li> <li>The media capability User A is ready to receive is specified.</li> </ul>
2.	INVITE—SIP proxy server to SIP redirect server	SIP proxy server sends the SIP INVITE request to the SIP redirect server.
3.	300 Multiple Choices—SIP redirect server to SIP proxy server	SIP redirect server sends a SIP 300 Multiple choices message to the SIP proxy server. The message indicates that User B can be reached either at SIP phone B or Cisco SIP IP phone C.
4.	INVITE—SIP proxy server to Cisco SIP IP phone B	SIP proxy server sends a SIP INVITE request to Cisco SIP IP phone B. The INVITE request is an invitation to User B to participate in a call session.
5.	486 Busy Here—Cisco SIP IP phone B to SIP proxy server	Cisco SIP IP phone B sends a 486 Busy here message to the SIP proxy server. The message indicates that Cisco SIP IP phone B is in use and the user is not willing or able to take additional calls.
6.	ACK—SIP proxy server to Cisco SIP IP phone B	SIP proxy server forwards the SIP ACK to the Cisco SIP IP phone B. The ACK confirms that the SIP proxy server has received the 486 Busy here response from Cisco SIP IP phone B.
7.	INVITE—SIP proxy server to Cisco SIP IP phone C	SIP proxy server sends a SIP INVITE request to Cisco SIP IP phone C. The INVITE request is an invitation to User C to participate in a call session.
8.	180 Ringing—Cisco SIP IP phone C to SIP proxy server	Cisco SIP IP phone C sends a SIP 180 Ringing response to the SIP proxy server
9.	200 OK—Cisco SIP IP phone C to SIP proxy server	Cisco SIP IP phone C sends a SIP 200 OK response to the SIP proxy server.
10.	200 OK—SIP proxy server to Cisco SIP IP phone A	SIP proxy server forwards the SIP 200 OK response to Cisco SIP IP phone A.

Step	Action	Description
11.	ACK—Cisco SIP IP phone A to SIP proxy server	Cisco SIP IP phone A sends a SIP ACK to the SIP proxy server. The ACK confirms that Cisco SIP IP phone A has received the 200 OK response from Cisco SIP IP phone C.
12.	ACK—SIP proxy server to Cisco SIP IP phone C	SIP proxy server forwards the SIP ACK to the Cisco SIP IP phone C. The ACK confirms that Cisco SIP IP phone A has received the 200 OK response from Cisco SIP IP phone C.

## Cisco SIP IP Phone-to-Cisco SIP IP Phone Network Call Forwarding (No Answer)

Figure B-12 illustrates successful call forwarding between Cisco SIP IP phones in which User B has requested call forwarding from the network in the event that there is no answer. When User A calls User B, the proxy server tries to place the call to Cisco SIP IP phone B and, if there is no answer, the call is transferred to Cisco SIP IP phone C. In this call flow scenario, the end users are User A, User B, and User C. They are all using Cisco SIP IP phones, which are connected via an IP network.

The call flow scenario is as follows:

1. User B requests that if the phone (Cisco SIP IP phone B) is not answered within a set amount of time, the network should forward incoming calls to Cisco SIP IP phone C.
2. User A calls User B.
3. User B's phone is not answered.
4. The network transfers the call to Cisco SIP IP phone C.

Figure B-12 Cisco SIP IP Phone-to-Cisco SIP IP Phone Network Call Forwarding (No Answer)

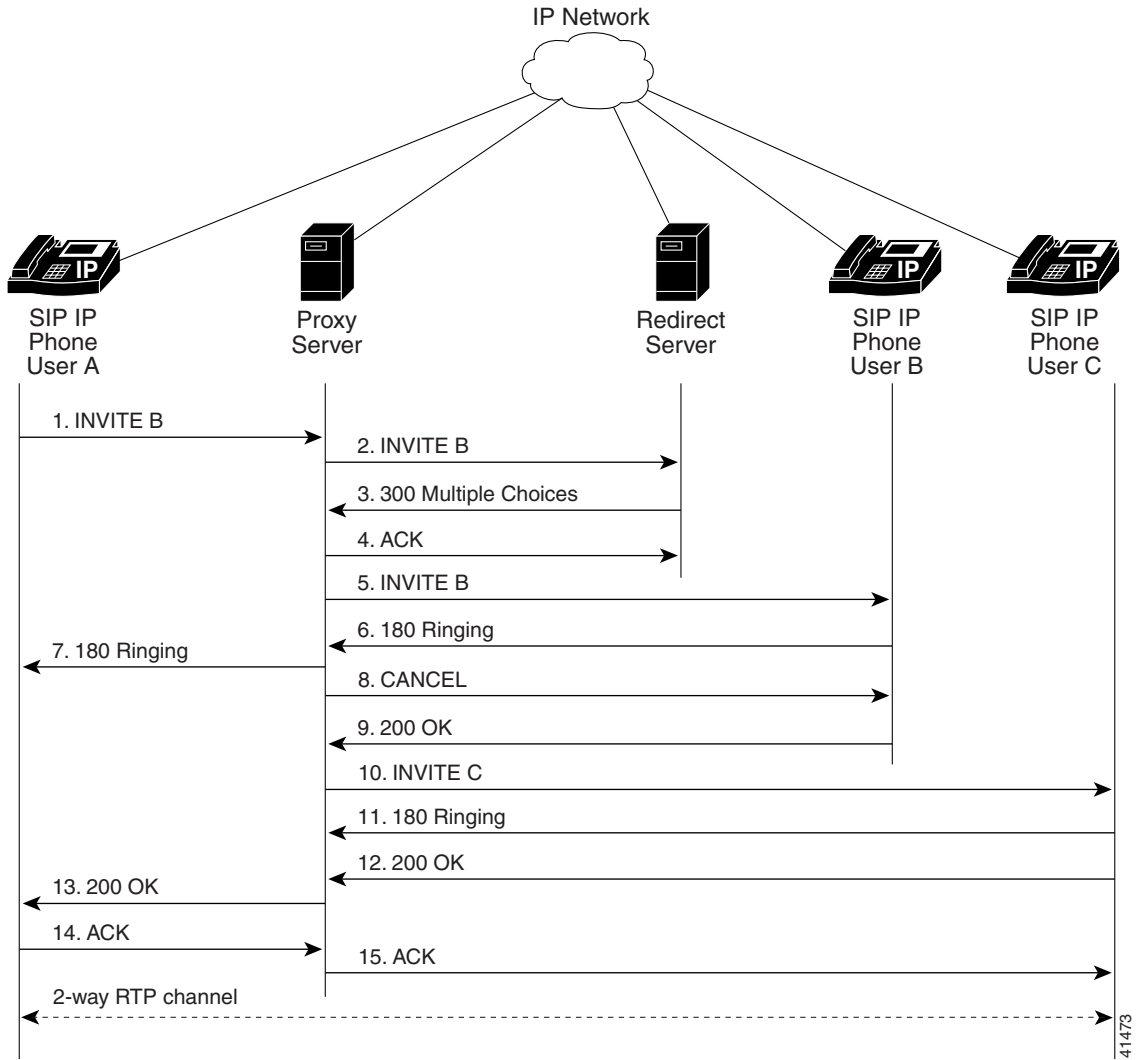

41473

Step	Action	Description
1.	INVITE—Cisco SIP IP phone A to SIP proxy server	<p>Cisco SIP IP phone A sends a SIP INVITE request to the SIP proxy server. The INVITE request is an invitation to User B to participate in a call session.</p> <p>In the INVITE request:</p> <ul style="list-style-type: none"> <li>The phone number of User B is inserted in the Request-URI field in the form of a SIP URL. The SIP URL identifies the address of User B and takes a form similar to an e-mail address (<i>user@host</i>, where <i>user</i> is the telephone number and <i>host</i> is either a domain name or a numeric network address). For example, the Request-URI field in the INVITE request to User B appears as “INVITE sip:555-0002@companyb.com; user=phone.” The “user=phone” parameter distinguishes that the Request-URI address is a telephone number rather than a username.</li> <li>Cisco SIP IP phone A is identified as the call session initiator in the From field.</li> <li>A unique numeric identifier is assigned to the call and is inserted in the Call-ID field.</li> <li>The transaction number within a single call leg is identified in the CSeq field.</li> <li>The media capability User A is ready to receive is specified.</li> </ul>
2.	INVITE—SIP proxy server to SIP redirect server	SIP proxy server sends the SIP INVITE request to the SIP redirect server.
3.	300 Multiple Choices—SIP redirect server to SIP proxy server	SIP redirect server sends a SIP 300 Multiple choices message to the SIP proxy server. The message indicates that User B can be reached either at SIP phone B or Cisco SIP IP phone C.
4.	INVITE—SIP proxy server to Cisco SIP IP phone B	SIP proxy server sends a SIP INVITE request to Cisco SIP IP phone B. The INVITE request is an invitation to User B to participate in a call session.
5.	180 Ringing—Cisco SIP IP phone B to SIP proxy server	Cisco SIP IP phone B sends a SIP 180 Ringing response to the SIP proxy server.
6.	180 Ringing—SIP proxy server to Cisco SIP IP phone A	SIP proxy server sends a SIP 180 Ringing response to Cisco SIP IP phone A.
The timeout expires before the phone is answered.		
7.	CANCEL (Ring Timeout)—SIP proxy server to Cisco SIP IP phone B	SIP proxy server sends a CANCEL request to Cisco SIP IP phone B to cancel the invitation.
8.	200 OK—Cisco SIP IP phone B to SIP proxy server	Cisco SIP IP phone B sends a SIP 200 OK response to the SIP proxy server. The response confirms receipt of the cancellation request.
9.	INVITE—SIP proxy server to Cisco SIP IP phone C	SIP proxy server sends a SIP INVITE request to Cisco SIP IP phone C. The INVITE request is an invitation to User C to participate in a call session.
10.	180 Ringing—Cisco SIP IP phone C to SIP proxy server	Cisco SIP IP phone C sends a SIP 180 Ringing response to the SIP proxy server.
11.	200 OK—Cisco SIP IP phone C to SIP proxy server	Cisco SIP IP phone C sends a SIP 200 OK response to the SIP proxy server.
12.	200 OK—SIP proxy server to Cisco SIP IP phone A	SIP proxy server forwards the SIP 200 OK response to Cisco SIP IP phone A.

Step	Action	Description
13.	ACK—Cisco SIP IP phone A to SIP proxy server	Cisco SIP IP phone A sends a SIP ACK to the SIP proxy server. The ACK confirms that Cisco SIP IP phone A has received the 200 OK response from Cisco SIP IP phone C.
14.	ACK—SIP proxy server to Cisco SIP IP phone C	SIP proxy server forwards the SIP ACK to the Cisco SIP IP phone C. The ACK confirms that Cisco SIP IP phone A has received the 200 OK response from Cisco SIP IP phone C.

## Cisco SIP IP Phone-to Cisco SIP IP Phone Three-Way Calling

Figure B-12 illustrates successful three-way calling between Cisco SIP IP phones in which User B mixes two RTP channels and therefore establishes a conference bridge between User A and User C. In this call flow scenario, the end users are User A, User B, and User C. They are all using Cisco SIP IP phones, which are connected via an IP network.

The call flow scenario is as follows:

1. User A calls User B.
2. User B answers the call.
3. User B puts User A on hold.
4. User B calls User C.
5. User C answers the call.
6. User B takes User A off hold.



Figure B-13 Cisco SIP IP Phone-to Cisco SIP IP Phone 3-Way Calling

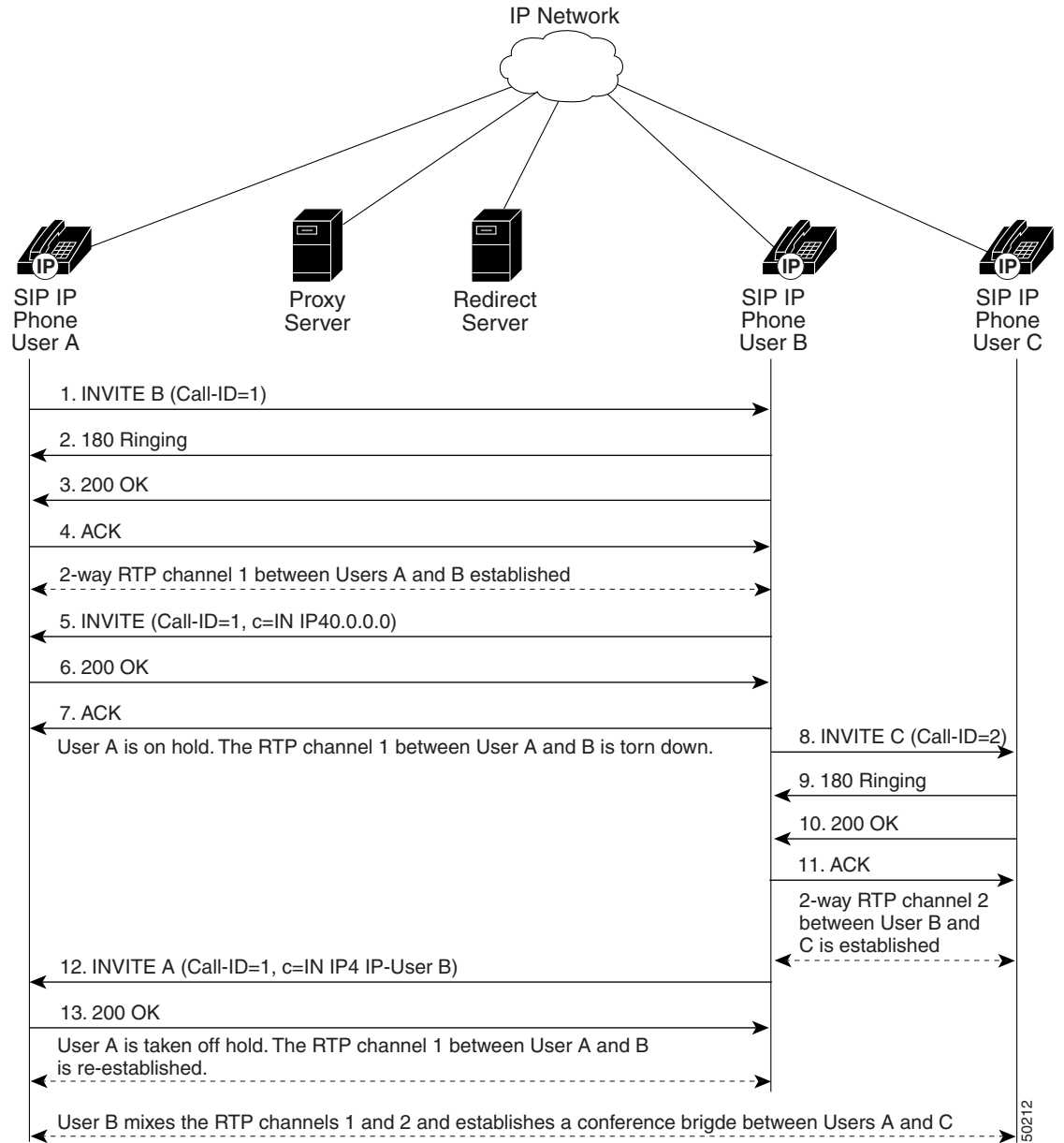

Step	Action	Description
1.	INVITE—Cisco SIP IP phone A to Cisco SIP IP phone B	<p>Cisco SIP IP phone A sends a SIP INVITE request to Cisco SIP IP phone B. The INVITE request is an invitation to User B to participate in a call session.</p> <p>In the INVITE request:</p> <ul style="list-style-type: none"> <li>The phone number of User B is inserted in the Request-URI field in the form of a SIP URL. The SIP URL identifies the address of User B and takes a form similar to an e-mail address (<i>user@host</i>, where <i>user</i> is the telephone number and <i>host</i> is either a domain name or a numeric network address). For example, the Request-URI field in the INVITE request to User B appears as “INVITE sip:555-0002@companyb.com; user=phone.” The “user=phone” parameter distinguishes that the Request-URI address is a telephone number rather than a username.</li> <li>Cisco SIP IP phone A is identified as the call session initiator in the From field.</li> <li>A unique numeric identifier is assigned to the call and is inserted in the Call-ID field.</li> <li>The transaction number within a single call leg is identified in the CSeq field.</li> <li>The media capability User A is ready to receive is specified.</li> </ul>
2.	180 Ringing—Cisco SIP IP phone B to Cisco SIP IP phone A	Cisco SIP IP phone B sends a SIP 180 Ringing response to Cisco SIP IP phone A.
3.	200 OK—Cisco SIP IP phone B to Cisco SIP IP phone A	<p>Cisco SIP IP phone B sends a SIP 200 OK response to Cisco SIP IP phone A. The 200 OK response notifies Cisco SIP IP phone A that the connection has been made.</p> <p>If Cisco SIP IP phone B supports the media capability advertised in the INVITE message sent by Cisco SIP IP phone A, it advertises the intersection of its own and Cisco SIP IP phone A’s media capability in the 200 OK response. If Cisco SIP IP phone B does not support the media capability advertised by Cisco SIP IP phone A, it sends back a 400 Bad Request response with a 304 Warning header field.</p>
4.	ACK—Cisco SIP IP phone A to Cisco SIP IP phone B	<p>Cisco SIP IP phone A sends a SIP ACK to Cisco SIP IP phone B. The ACK confirms that Cisco SIP IP phone A has received the 200 OK response from Cisco SIP IP phone B.</p> <p>The ACK might contain a message body with the final session description to be used by Cisco SIP IP phone B. If the message body of the ACK is empty, Cisco SIP IP phone B uses the session description in the INVITE request.</p>
A two-way RTP channel is established between Cisco SIP IP phone A and Cisco SIP IP phone B.		
5.	INVITE—Cisco SIP IP phone B to Cisco SIP IP phone A	<p>Cisco SIP IP phone B sends a mid-call INVITE to Cisco SIP IP phone A with new SDP session parameters (IP address), which are used to place the call on hold.</p> <pre>Call_ID=1 SDP: c=IN IP4 0.0.0.0</pre> <p>The c= SDP field of the SIP INVITE contains an 0.0.0.0. This places the call in hold.</p>
6.	200 OK—Cisco SIP IP phone A to Cisco SIP IP phone B	Cisco SIP IP phone A sends a SIP 200 OK response to Cisco SIP IP phone B.

Step	Action	Description
7.	ACK—Cisco SIP IP phone B to Cisco SIP IP phone A	Cisco SIP IP phone B sends a SIP ACK to Cisco SIP IP phone A. The ACK confirms that Cisco SIP IP phone B has received the 200 OK response from Cisco SIP IP phone A.
The RTP channel between Cisco SIP IP phone A and Cisco SIP IP phone B is torn down. User A is put on hold.		
8.	INVITE—Cisco SIP IP phone B to Cisco SIP IP phone C	<p>Cisco SIP IP phone B sends a SIP INVITE request to Cisco SIP IP phone C. The INVITE request is an invitation to User B to participate in a call session.</p> <p>In the INVITE request:</p> <ul style="list-style-type: none"> <li>• The phone number of User B is inserted in the Request-URI field in the form of a SIP URL. The SIP URL identifies the address of User B and takes a form similar to an e-mail address (<i>user@host</i>, where <i>user</i> is the telephone number and <i>host</i> is either a domain name or a numeric network address). For example, the Request-URI field in the INVITE request to User C appears as “INVITE sip:555-0002@companyb.com; user=phone.” The “user=phone” parameter distinguishes that the Request-URI address is a telephone number rather than a username.</li> <li>• Cisco SIP IP phone B is identified as the call session initiator in the From field.</li> <li>• A unique numeric identifier is assigned to the call and is inserted in the Call-ID field.</li> <li>• The transaction number within a single call leg is identified in the CSeq field.</li> <li>• The media capability User B is ready to receive is specified.</li> </ul>
9.	180 Ringing—Cisco SIP IP phone C to Cisco SIP IP phone B	Cisco SIP IP phone C sends a SIP 180 Ringing response to Cisco SIP IP phone B.
10.	200 OK—Cisco SIP IP phone C to Cisco SIP IP phone B	<p>Cisco SIP IP phone C sends a SIP 200 OK response to Cisco SIP IP phone B. The 200 OK response notifies Cisco SIP IP phone B that the connection has been made.</p> <p>If Cisco SIP IP phone C supports the media capability advertised in the INVITE message sent by Cisco SIP IP phone B, it advertises the intersection of its own and Cisco SIP IP phone B’s media capability in the 200 OK response. If Cisco SIP IP phone C does not support the media capability advertised by Cisco SIP IP phone B, it sends back a 400 Bad Request response with a 304 Warning header field.</p>
11.	ACK—Cisco SIP IP phone B to Cisco SIP IP phone C	<p>Cisco SIP IP phone B sends a SIP ACK to Cisco SIP IP phone C. The ACK confirms that Cisco SIP IP phone B has received the 200 OK response from Cisco SIP IP phone C.</p> <p>The ACK might contain a message body with the final session description to be used by Cisco SIP IP phone C. If the message body of the ACK is empty, Cisco SIP IP phone C uses the session description in the INVITE request.</p>

A two-way RTP channel is established between SIP IP phone B and SIP IP phone C.

Step	Action	Description
12.	INVITE—Cisco SIP IP phone B to Cisco SIP IP phone A	<p>Cisco SIP IP phone B sends a mid-call INVITE to Cisco SIP IP phone A with the same call ID as the previous INVITE and new SDP session parameters (IP address), which are used to reestablish the call.</p> <pre>Call_ID=1 SDP: c=IN IP4 181.23.250.2</pre> <p>To reestablish the call between phone A and phone B, the IP address of phone B is inserted into the c= SDP field.</p>
13.	200 OK—Cisco SIP IP phone A to Cisco SIP IP phone B	Cisco SIP IP phone A sends a SIP 200 OK response to Cisco SIP IP phone B.
14.	ACK—Cisco SIP IP phone B to Cisco SIP IP phone A	Cisco SIP IP phone B sends a SIP ACK to Cisco SIP IP phone A. The ACK confirms that Cisco SIP IP phone B has received the 200 OK response from Cisco SIP IP phone A.

SIP IP phone B acts as a bridge mixing the RTP channel between User A and User B with the channel between User B and User C; establishing a conference bridge between User A and User C.

## Call Flow Scenarios for Failed Calls

This section describes call flows for the following scenarios, which illustrate unsuccessful calls:

- Gateway-to-Cisco SIP IP Phone—Called User Is Busy, page B-46
- Gateway-to-Cisco SIP IP Phone—Called User Does Not Answer, page B-48
- Gateway-to-Cisco SIP IP Phone—Client, Server, or Global Error, page B-50
- Cisco SIP IP Phone-to-Cisco SIP IP Phone—Called User Is Busy, page B-52
- Cisco SIP IP Phone-to-Cisco SIP IP Phone—Called User Does Not Answer, page B-53
- Cisco SIP IP Phone-to-Cisco SIP IP Phone—Authentication Error, page B-54

### Gateway-to-Cisco SIP IP Phone—Called User Is Busy

Figure B-14 illustrates an unsuccessful call in which User A initiates a call to User B, but User B is on the phone and is unable or unwilling to take another call.

Figure B-14 Gateway-to-Cisco SIP IP Phone—Called User is Busy

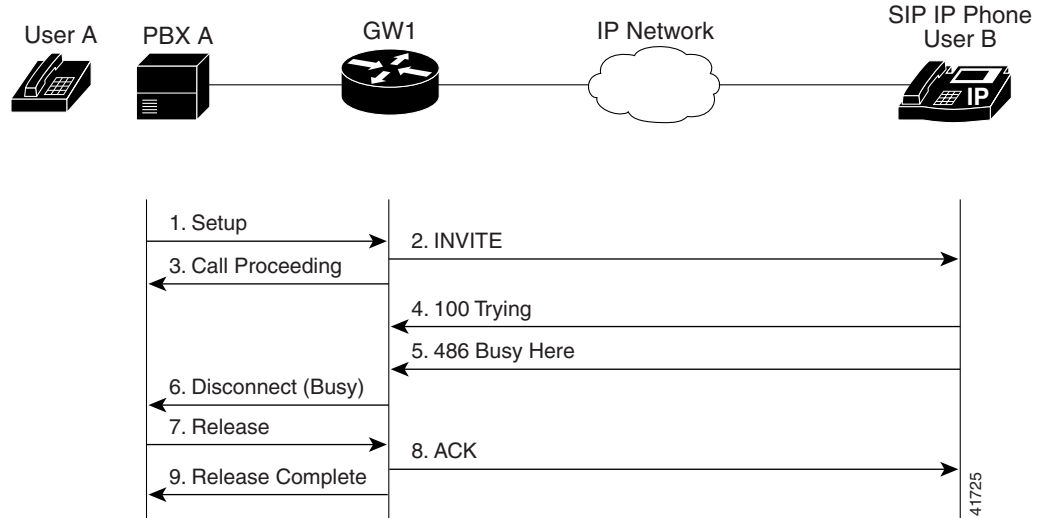

Step	Action	Description
1.	Setup—PBX A to Gateway 1	Call Setup is initiated between PBX A and Gateway 1. The Call Setup includes the standard transactions that take place as User A attempts to call User B.
2.	INVITE—Gateway 1 to Cisco SIP IP phone	Gateway 1 maps the SIP URL phone number to a dial peer. The dial peer includes the IP address and the port number of the SIP enabled entity to contact. Gateway 1 sends a SIP INVITE request to the address it receives as the dial peer which, in this scenario, is the Cisco SIP IP phone. In the INVITE request: <ul style="list-style-type: none"> <li>• The IP address of the Cisco SIP IP phone is inserted in the Request-URI field.</li> <li>• PBX A is identified as the call session initiator in the From field.</li> <li>• A unique numeric identifier is assigned to the call and is inserted in the Call-ID field.</li> <li>• The transaction number within a single call leg is identified in the CSeq field.</li> <li>• The media capability User A is ready to receive is specified.</li> <li>• The port on which the gateway is prepared to receive the RTP data is specified.</li> </ul>
3.	Call Proceeding—Gateway 1 to PBX A	Gateway 1 sends a Call Proceeding message to PBX A to acknowledge the Call Setup request.
4.	100 Trying—Cisco SIP IP phone to Gateway 1	The Cisco SIP IP phone sends a SIP 100 Trying response to Gateway 1. The 100 Trying response indicates that the INVITE request has been received by the Cisco SIP IP phone.
5.	486 Busy Here—Cisco SIP IP phone to Gateway 1	The Cisco SIP IP phone sends a SIP 486 Busy Here response to Gateway 1. The 486 Busy Here response is a client error response that indicates that User B was successfully contacted but that User B was not willing or was unable to take the call.

Step	Action	Description
6.	Disconnect (Busy)—Gateway 1 to PBX A	Gateway 1 sends a Disconnect message to PBX A.
7.	Release—PBX A to Gateway 1	PBX A sends a Release message to Gateway 1.
8.	ACK—Gateway 1 to Cisco SIP IP phone	Gateway 1 sends a SIP ACK to the Cisco SIP IP phone. The ACK confirms that User A has received the 486 Busy Here response. The call session attempt is now being terminated.
9.	Release Complete—Gateway 1 to PBX A	Gateway 1 sends a Release Complete message to PBX A and the call session attempt is terminated.

## Gateway-to-Cisco SIP IP Phone—Called User Does Not Answer

Figure B-15 illustrates the call flow in which User A initiates a call to User B but User B does not answer.

**Figure B-15 Gateway-to-Cisco SIP IP Phone—Called User Does Not Answer**

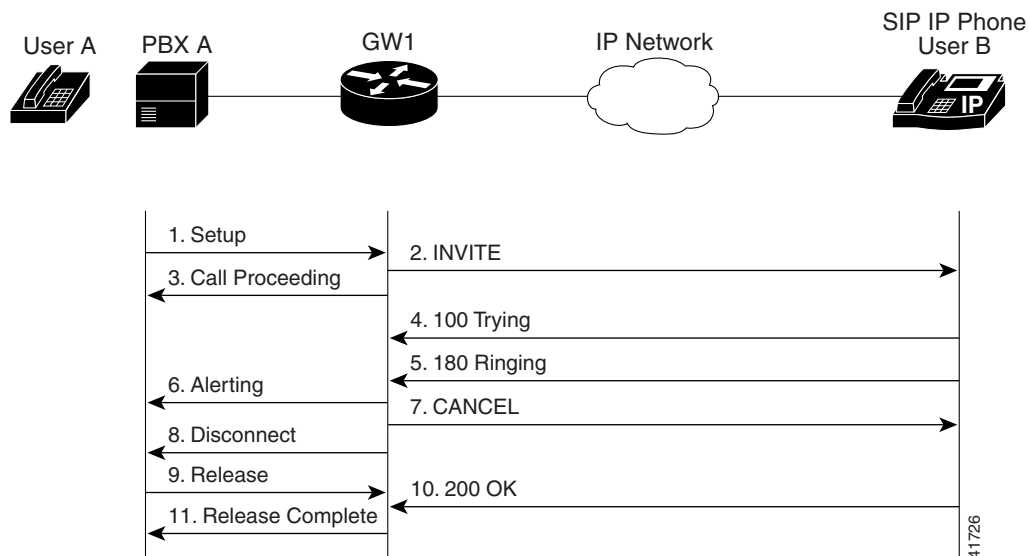

Step	Action	Description
1.	Setup—PBX A to Gateway 1	Call Setup is initiated between PBX A and Gateway 1. The Call Setup includes the standard transactions that take place as User A attempts to call User B.
2.	INVITE—Gateway 1 to Cisco SIP IP phone	<p>Gateway 1 maps the SIP URL phone number to a dial peer. The dial peer includes the IP address and the port number of the SIP enabled entity to contact. Gateway 1 sends a SIP INVITE request to the address it receives as the dial peer which, in this scenario, is the Cisco SIP IP phone.</p> <p>In the INVITE request:</p> <ul style="list-style-type: none"> <li>• The IP address of the Cisco SIP IP phone is inserted in the Request-URI field.</li> <li>• PBX A is identified as the call session initiator in the From field.</li> <li>• A unique numeric identifier is assigned to the call and is inserted in the Call-ID field.</li> <li>• The transaction number within a single call leg is identified in the CSeq field.</li> <li>• The media capability User A is ready to receive is specified.</li> <li>• The port on which the Gateway is prepared to receive the RTP data is specified.</li> </ul>
3.	Call Proceeding—Gateway 1 to PBX A	Gateway 1 sends a Call Proceeding message to PBX A to acknowledge the Call Setup request.
4.	100 Trying—Cisco SIP IP phone to Gateway 1	The Cisco SIP IP phone sends a SIP 100 Trying response to Gateway 1. The 100 Trying response indicates that the INVITE request has been received by the Cisco SIP IP phone.
5.	180 Ringing—Cisco SIP IP phone to Gateway 1	The Cisco SIP IP phone sends a SIP 180 Ringing response to Gateway 1. The 180 Ringing response indicates that the user is being alerted.
6.	Alerting—Gateway 1 to PBX A	Gateway 1 sends an Alert message to PBX A.
7.	CANCEL (Ring Timeout)—Gateway 1 to Cisco SIP IP phone	Because Gateway 1 did not return an appropriate response within the time allocated in the INVITE request, Gateway 1 sends a SIP CANCEL request to Gateway 2. A CANCEL request cancels a pending request with the same Call-ID, To, From, and CSeq header field values.
8.	Disconnect—Gateway 1 to PBX A	Gateway 1 sends a Disconnect message to PBX A.
9.	Release Complete—Gateway 1 to PBX A	Gateway 1 sends a Release Complete message to PBX A and the call session attempt is terminated.
10.	200 OK—Cisco SIP IP phone to Gateway 1	The Cisco SIP IP phone sends a SIP 200 OK response to Gateway 1. The 200 OK response confirms that User A has received the 486 Busy Here response. The call session attempt is now being terminated.
11.	Release Complete—Gateway 1 to PBX A	Gateway 1 sends a Release Complete message to PBX A and the call session is terminated.

## Gateway-to-Cisco SIP IP Phone—Client, Server, or Global Error

Figure B-16 illustrates an unsuccessful call in which User A initiates a call to User B and receives a class 4xx, 5xx, or 6xx response.

**Figure B-16 Gateway-to-Cisco SIP IP Phone—Client, Server, or Global Error**

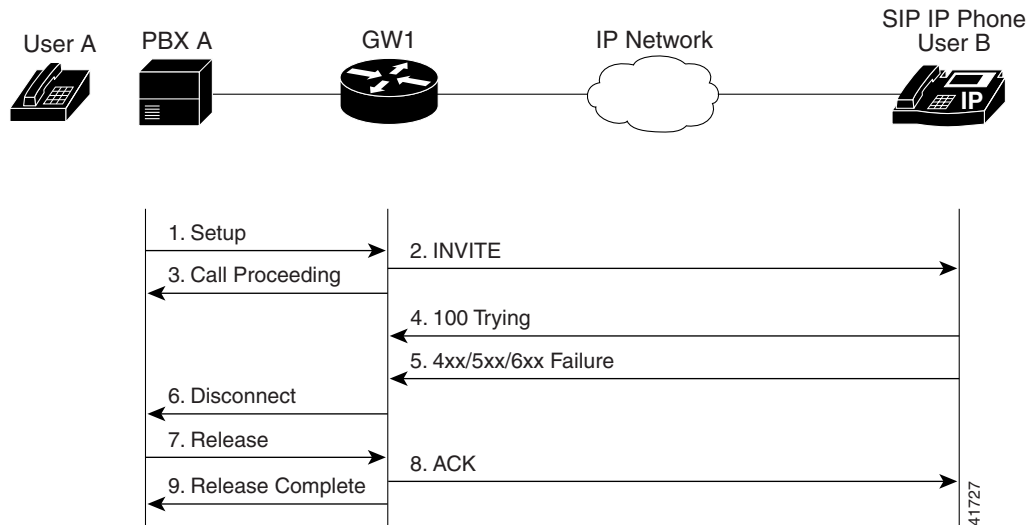

Step	Action	Description
1.	Setup—PBX A to Gateway 1	Call Setup is initiated between PBX A and Gateway 1. The Call Setup includes the standard transactions that take place as User A attempts to call User B.
2.	INVITE—Gateway 1 to Cisco SIP IP phone	<p>Gateway 1 maps the SIP URL phone number to a dial peer. The dial peer includes the IP address and the port number of the SIP enabled entity to contact. Gateway 1 sends a SIP INVITE request to the address it receives as the dial peer which, in this scenario, is the Cisco SIP IP phone.</p> <p>In the INVITE request:</p> <ul style="list-style-type: none"> <li>• The IP address of the Cisco SIP IP phone is inserted in the Request-URI field.</li> <li>• PBX A is identified as the call session initiator in the From field.</li> <li>• A unique numeric identifier is assigned to the call and is inserted in the Call-ID field.</li> <li>• The transaction number within a single call leg is identified in the CSeq field.</li> <li>• The media capability User A is ready to receive is specified.</li> <li>• The port on which the gateway is prepared to receive the RTP data is specified.</li> </ul>



Step	Action	Description
3.	Call Proceeding—Gateway 1 to PBX A	Gateway 1 sends a Call Proceeding message to PBX A to acknowledge the Call Setup request.
4.	100 Trying—Cisco SIP IP phone to Gateway 1	The Cisco SIP IP phone sends a SIP 100 Trying response to Gateway 1. The 100 Trying response indicates that the INVITE request has been received by the Cisco SIP IP phone.
5.	4xx/5xx/6xx Failure—Cisco SIP IP phone to Gateway 1	<p>The Cisco SIP IP phone sends a class 4xx, 5xx, or class 6xx failure response to Gateway 1. Depending on which class the failure response is, the call actions differ.</p> <p>If the Cisco SIP IP phone sends a class 4xx failure response (a definite failure response that is a client error), the request will not be retried without modification.</p> <p>If the Cisco SIP IP phone sends a class 5xx failure response (an indefinite failure that is a server error), the request is not terminated but rather other possible locations are tried.</p> <p>If the Cisco SIP IP phone sends a class 6xx failure response (a global error), the search for User B is terminated because the 6xx response indicates that a server has definite information about User B, but not for the particular instance indicated in the Request-URI field. Therefore, all further searches for this user will fail.</p>
6.	Disconnect—Gateway 1 to PBX A	Gateway 1 sends a Release message to PBX A.
7.	Release—PBX A to Gateway 1	PBX A sends a Release message to Gateway 1.
8.	ACK—Gateway 1 to Cisco SIP IP phone	Gateway 1 sends a SIP ACK to the Cisco SIP IP phone. The ACK confirms that User A has received the 486 Busy Here response. The call session attempt is now being terminated.
9.	Release Complete—Gateway 1 to PBX A	Gateway 1 sends a Release Complete message to PBX A and the call session attempt is terminated.

## Cisco SIP IP Phone-to-Cisco SIP IP Phone—Called User Is Busy

Figure B-17 illustrates an unsuccessful call in which User A initiates a call to User B but User B is on the phone and is unable or unwilling to take another call.

**Figure B-17 Cisco SIP IP Phone-to-Cisco SIP IP Phone—Called User Is Busy**

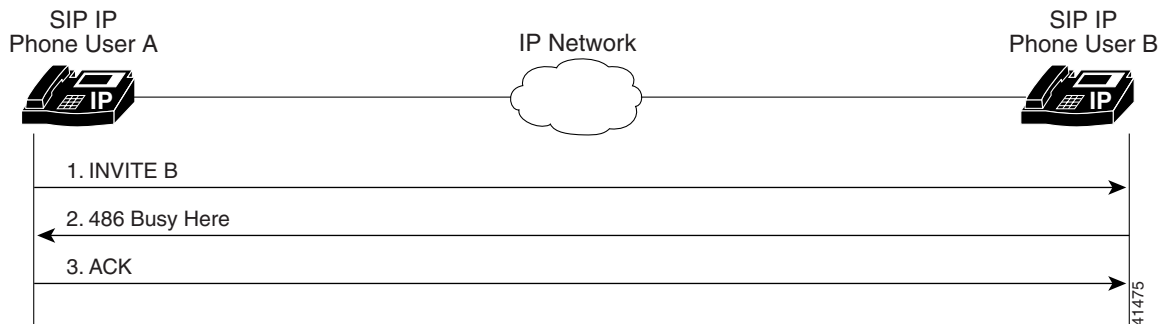

Step	Action	Description
1.	INVITE—Cisco SIP IP phone A to Cisco SIP IP phone B	<p>Cisco SIP IP phone A sends a SIP INVITE request to Cisco SIP IP phone B. The INVITE request is an invitation to User B to participate in a call session.</p> <p>In the INVITE request:</p> <ul style="list-style-type: none"> <li>The phone number of User B is inserted in the Request-URI field in the form of a SIP URL. The SIP URL identifies the address of User B and takes a form similar to an e-mail address (<i>user@host</i>, where <i>user</i> is the telephone number and <i>host</i> is either a domain name or a numeric network address). For example, the Request-URI field in the INVITE request to User B appears as “INVITE sip:555-0002@companyb.com; user=phone.” The “user=phone” parameter distinguishes that the Request-URI address is a telephone number rather than a username.</li> <li>Cisco SIP IP phone A is identified as the call session initiator in the From field.</li> <li>A unique numeric identifier is assigned to the call and is inserted in the Call-ID field.</li> <li>The transaction number within a single call leg is identified in the CSeq field.</li> <li>The media capability User A is ready to receive is specified.</li> </ul>
2.	486 Busy Here—Cisco SIP IP phone B to Cisco SIP IP phone A	<p>Cisco SIP IP phone B sends a 486 Busy here message to the Cisco SIP IP phone A. The message indicates that Cisco SIP IP phone B is in use and the user is not willing or able to take additional calls.</p>
3.	ACK—Cisco SIP IP phone A to Cisco SIP IP phone B	<p>Cisco SIP IP phone A sends a SIP ACK to the Cisco SIP IP phone B. The ACK confirms that Cisco SIP IP phone A has received the 486 Busy Here response from Cisco SIP IP phone B.</p>

## Cisco SIP IP Phone-to-Cisco SIP IP Phone—Called User Does Not Answer

Figure B-18 illustrates an unsuccessful call in which User A initiates a call to User B but User B does not answer.

**Figure B-18 Cisco SIP IP Phone-to-Cisco SIP IP Phone—Called User Does Not Answer**

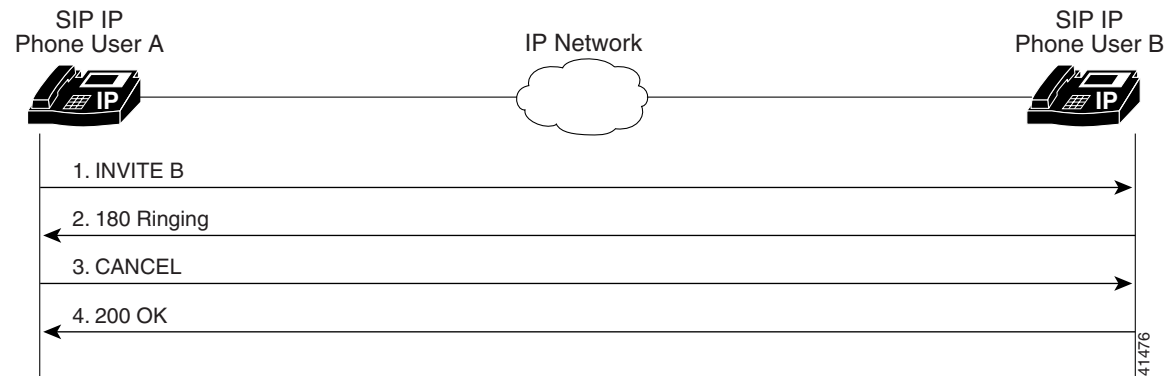

Step	Action	Description
1.	INVITE—Cisco SIP IP phone A to Cisco SIP IP phone B	<p>Cisco SIP IP phone A sends a SIP INVITE request to Cisco SIP IP phone B. The INVITE request is an invitation to User B to participate in a call session.</p> <p>In the INVITE request:</p> <ul style="list-style-type: none"> <li>The phone number of User B is inserted in the Request-URI field in the form of a SIP URL. The SIP URL identifies the address of User B and takes a form similar to an e-mail address (<i>user@host</i>, where <i>user</i> is the telephone number and <i>host</i> is either a domain name or a numeric network address). For example, the Request-URI field in the INVITE request to User B appears as “INVITE sip:555-0002@companyb.com; user=phone.” The “user=phone” parameter distinguishes that the Request-URI address is a telephone number rather than a username.</li> <li>Cisco SIP IP phone A is identified as the call session initiator in the From field.</li> <li>A unique numeric identifier is assigned to the call and is inserted in the Call-ID field.</li> <li>The transaction number within a single call leg is identified in the CSeq field.</li> <li>The media capability User A is ready to receive is specified.</li> </ul>
2.	180 Ringing—Cisco SIP IP phone B to Cisco SIP IP phone A	Cisco SIP IP phone B sends a SIP 180 Ringing response to Cisco SIP IP phone A.
3.	CANCEL (Ring Timeout)—Cisco SIP IP phone A to Cisco SIP IP phone B	Cisco SIP IP phone A sends a CANCEL request to Cisco SIP IP phone B to cancel the invitation.
4.	200 OK—Cisco SIP IP phone B to Cisco SIP IP phone A	Cisco SIP IP phone B sends a SIP 200 OK response to Cisco SIP IP phone A. The response confirms receipt of the cancellation request.

## Cisco SIP IP Phone-to-Cisco SIP IP Phone—Authentication Error

Figure B-19 illustrates an unsuccessful call in which User A initiates a call to User B but is prompted for authentication credentials by the proxy server. User A's SIP IP phone then reinitiates the call with an SIP INVITE request that includes its authentication credentials.

**Figure B-19 Cisco SIP IP Phone-to-Cisco SIP IP Phone—Authentication Error**

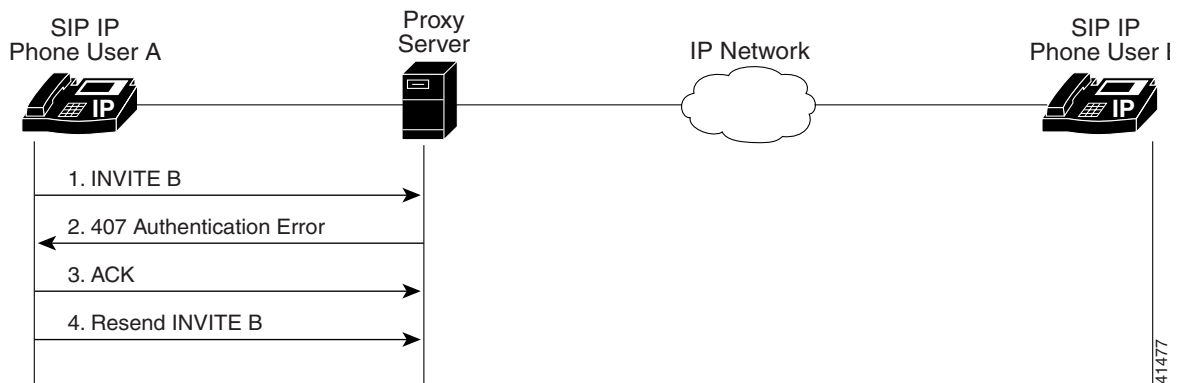

41477

Step	Action	Description
1.	INVITE—Cisco SIP IP phone A to SIP proxy server	<p>Cisco SIP IP phone A sends a SIP INVITE request to the SIP proxy server. The INVITE request is an invitation to User B to participate in a call session.</p> <p>In the INVITE request:</p> <ul style="list-style-type: none"> <li>The phone number of User B is inserted in the Request-URI field in the form of a SIP URL. The SIP URL identifies the address of User B and takes a form similar to an e-mail address (<i>user@host</i>, where <i>user</i> is the telephone number and <i>host</i> is either a domain name or a numeric network address). For example, the Request-URI field in the INVITE request to User B appears as “INVITE sip:555-0002@companyb.com; user=phone.” The “user=phone” parameter distinguishes that the Request-URI address is a telephone number rather than a username.</li> <li>Cisco SIP IP phone A is identified as the call session initiator in the From field.</li> <li>A unique numeric identifier is assigned to the call and is inserted in the Call-ID field.</li> <li>The transaction number within a single call leg is identified in the CSeq field.</li> <li>The media capability User A is ready to receive is specified.</li> </ul>
2.	407 Authentication Error—SIP proxy server to Cisco SIP IP phone A	SIP proxy server sends a SIP 407 Authentication Error response to Cisco SIP IP phone A.
3.	ACK—Cisco SIP IP phone A to SIP proxy server	Cisco SIP IP phone A sends a SIP ACK to the SIP proxy server acknowledging the 407 error message.
4.	Resend INVITE—Cisco SIP IP phone A to SIP proxy server	Cisco SIP IP phone A resends a SIP INVITE to the SIP proxy server with authentication credentials.

# Call from a Cisco SIP IP Phone to a Gateway Acting as a Backup Proxy

Figure B-20 illustrates a successful call from a Cisco SIP IP phone to a gateway acting as a backup proxy.

**Figure B-20 A Successful Call from a Cisco SIP IP Phone to a Gateway (Backup Proxy)**

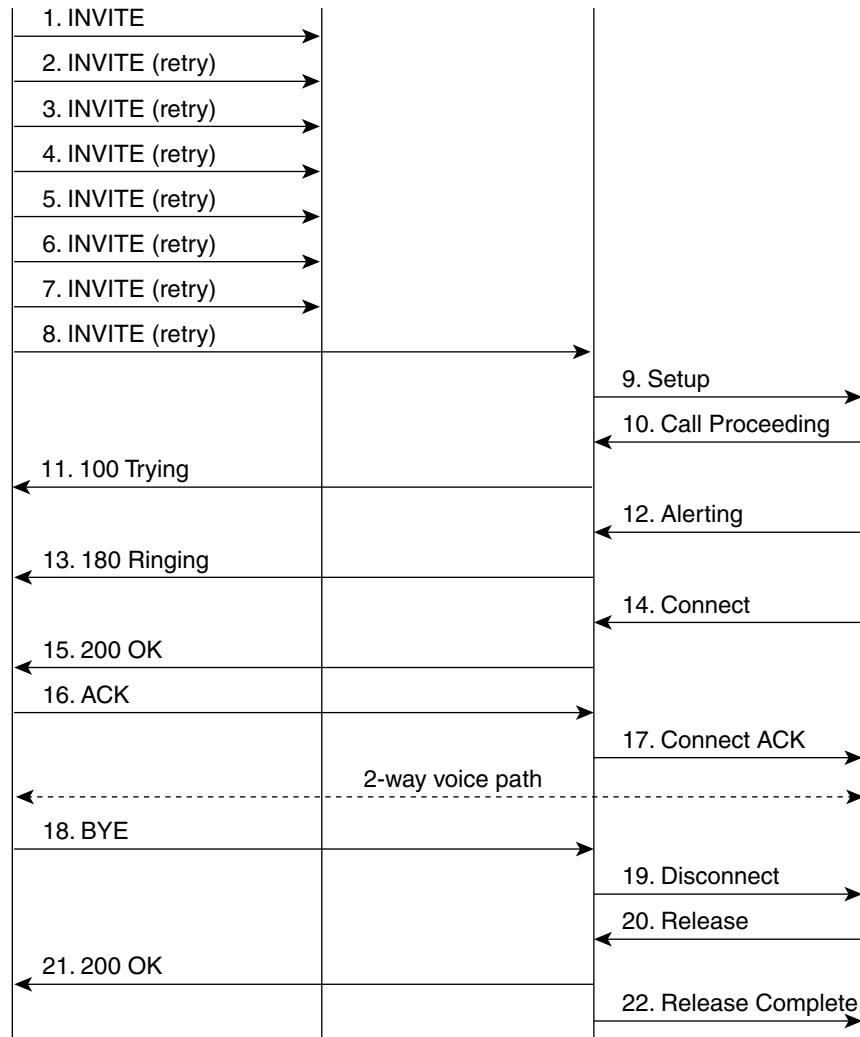
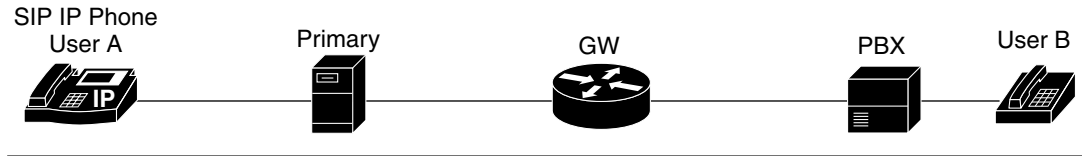

62028

Step	Action	Description
1.	INVITE—Cisco SIP IP phone to primary proxy	Cisco SIP IP phone tries to connect to the proxy by sending out the INVITE message.
2.	INVITE—Cisco SIP IP phone to primary proxy (second try)	Cisco SIP IP phone retries a second time to connect to the proxy by sending out the INVITE message.
3.	INVITE—Cisco SIP IP phone to primary proxy (third try)	Cisco SIP IP phone retries a third time to connect to the proxy by sending out the INVITE message.
4.	INVITE—Cisco SIP IP phone to primary proxy (fourth try)	Cisco SIP IP phone retries a fourth time to connect to the proxy by sending out the INVITE message.
5.	INVITE—Cisco SIP IP phone to primary proxy (fifth try)	Cisco SIP IP phone retries a fifth time to connect to the proxy by sending out the INVITE message.
6.	INVITE—Cisco SIP IP phone to primary proxy (sixth try)	Cisco SIP IP phone retries a sixth time to connect to the proxy by sending out the INVITE message.
7.	INVITE—Cisco SIP IP phone to primary proxy (seventh try)	Cisco SIP IP phone retries a seventh time to connect to the proxy. If the connection is not successful after this trial, “Network Delay, Trying Backup” message displays on the Phone.
8.	INVITE—Cisco SIP IP phone to gateway (backup proxy)	Cisco SIP IP phone tries to connect to the gateway (backup proxy) by sending out the INVITE message.
9.	Setup—Gateway to PBX	Call Setup is initiated between gateway to PBX. The Call Setup includes the standard transactions that take place as User A attempts to call User B.
10.	Call Proceeding—PBX to gateway	PBX sends a Call Proceeding message to gateway to acknowledge the Call Setup request.
11.	100 Trying—Gateway to Cisco SIP IP phone (User A)	Gateway sends a SIP 100 Trying response to User A. The 100 Trying response indicates that the INVITE request has been received by the gateway.
12.	Alerting—PBX to gateway	PBX sends an Alert message to gateway. The Alert message indicates that PBX has received a 100 Trying Ringing response from the gateway.
13.	180 Ringing—Gateway to Cisco SIP IP phone (User A)	The gateway sends a SIP 180 Ringing response to User A. The 180 Ringing response indicates that the gateway is being alerted.
14.	Connect—PBX to gateway	PBX sends a Connect message to gateway. The Connect message notifies the gateway that the connection has been made.
15.	200 OK—Gateway to Cisco SIP IP phone (User A)	Gateway sends a SIP 200 OK response to the User A. The 200 OK response notifies User A that the connection has been made.
16.	ACK—Cisco SIP IP phone (User A) to gateway	User A sends a SIP ACK to the gateway. The ACK confirms that User A has received the 200 OK response. The call session is now active.
17.	Connect ACK—Gateway to PBX	Gateway acknowledges PBX’s Connect message.
18.	BYE—Cisco SIP IP phone (User A) to gateway	User A terminates the call session and sends a SIP BYE request to gateway. The BYE request indicates that User A wants to release the call.
19.	Disconnect—Gateway to PBX	Gateway sends a Disconnect message to PBX.
20.	Release—PBX to gateway	PBX sends a Release message to gateway.

<b>Step</b>	<b>Action</b>	<b>Description</b>
21.	200 OK—Gateway to Cisco SIP IP phone (User A)	Gateway sends a SIP 200 OK response to User A. The 200 OK response notifies User A that the gateway has received the BYE request.
22.	Release Complete—Gateway to PBX	Gateway sends a Release Complete message to PBX and the call session is terminated.

## Call from a Cisco SIP IP Phone to a Cisco SIP IP Phone via a Backup Proxy

Figure B-21 illustrates a successful call from a Cisco SIP IP phone to a Cisco SIP IP phone via a backup proxy.

**Figure B-21 A Successful Call from a Cisco SIP IP Phone to a Cisco SIP IP Phone via a Backup Proxy**

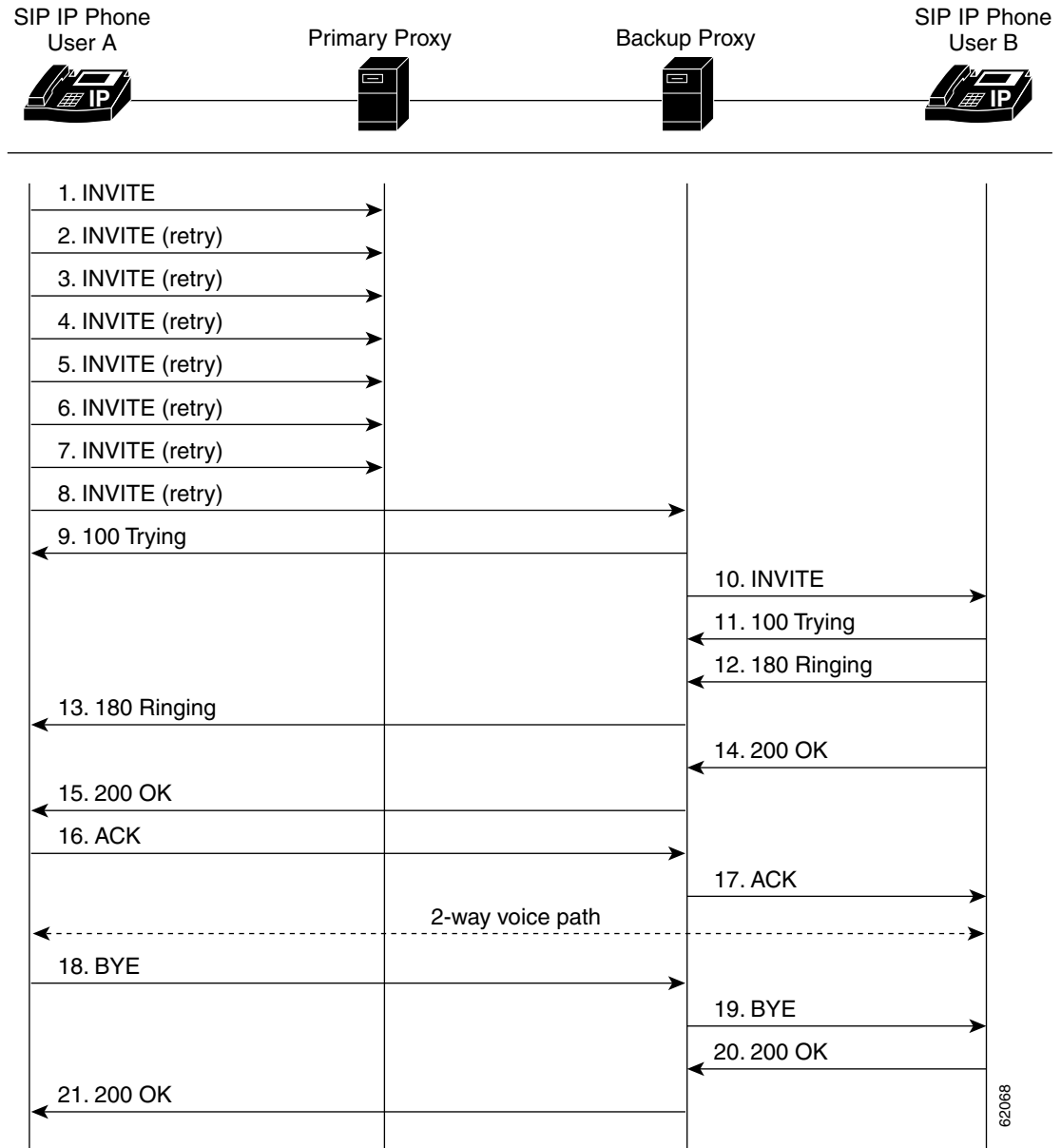



Step	Action	Description
1.	INVITE—Cisco SIP IP Phone (User A) to primary proxy	Cisco SIP IP Phone tries to connect to the primary proxy by sending out the INVITE message.
2.	INVITE—Cisco SIP IP phone (User A) to primary proxy (second try)	Cisco SIP IP phone retries a second time to connect to the primary proxy by sending out the INVITE message.
3.	INVITE—Cisco SIP IP phone (User A) to primary proxy (third try)	Cisco SIP IP phone retries a third time to connect to the primary proxy by sending out the INVITE message.
4.	INVITE—Cisco SIP IP phone (User A) to primary proxy (fourth try)	Cisco SIP IP phone retries a fourth time to connect to the primary proxy by sending out the INVITE message.
5.	INVITE—Cisco SIP IP phone (User A) to primary proxy (fifth try)	Cisco SIP IP phone retries a fifth time to connect to the primary proxy by sending out the INVITE message.
6.	INVITE—Cisco SIP IP phone (User A) to primary proxy (sixth try)	Cisco SIP IP phone retries a sixth time to connect to the primary proxy by sending out the INVITE message.
7.	INVITE—Cisco SIP IP phone (User A) to primary proxy (seventh try)	Cisco SIP IP phone retries a seventh time to connect to the primary proxy. If the connection is not successful after this trial, the “Network Delay, Trying Backup” message displays on the Phone.
8.	INVITE—Cisco SIP IP phone (User A) to backup proxy	Cisco SIP IP phone tries to connect to the backup proxy by sending out the INVITE message.
9.	100 Trying—Backup proxy to Cisco SIP IP phone (User A)	Backup proxy sends a SIP 100 Trying response to Cisco SIP IP phone. The 100 Trying response indicates that the INVITE request has been received by the backup proxy.
10.	INVITE—Backup proxy to Cisco SIP IP phone (User B)	Backup proxy tries to connect to User B by sending out the INVITE message.
11.	100 Trying—Cisco SIP IP phone (User B) to backup proxy	User B sends a SIP 100 Trying response to backup proxy. The 100 Trying response indicates that the INVITE request has been received by User B.
12.	180 Ringing—Cisco SIP IP phone (User B) to backup proxy	User B sends a SIP 180 Ringing response to the backup proxy. The 180 Ringing response indicates that User B is being alerted.
13.	180 Ringing—Backup proxy to Cisco SIP IP phone (User A)	The backup proxy sends a SIP 180 Ringing response to User A. The 180 Ringing response indicates that the backup proxy is being alerted.
14.	200 OK—Cisco SIP IP phone (User B) to backup proxy	User B sends a SIP 200 OK response to the backup proxy. The 200 OK response notifies the backup proxy that the connection has been made.
15.	200 OK—Backup proxy to Cisco SIP IP phone (User A)	Backup proxy sends a SIP 200 OK response to User A. The 200 OK response notifies User A that the connection has been made.
16.	ACK—Cisco SIP IP phone (User A) to backup proxy	User A acknowledges backup proxy’s Connect message.
17.	ACK—Backup proxy to Cisco SIP IP phone (User B)	Backup proxy acknowledges User B’s Connect message.
18.	BYE—Cisco SIP IP phone (User A) to backup proxy	User A terminates the call session and sends a SIP BYE request to backup proxy. The BYE request indicates that User A wants to release the call.

Step	Action	Description
19.	BYE—Backup proxy to Cisco SIP IP phone (User B)	Backup proxy terminates the call session and sends a SIP BYE request to User B. The BYE request indicates that the backup proxy wants to release the call.
20.	200 OK—Cisco SIP IP phone (User B) to backup proxy	User B sends a SIP 200 OK response to the backup proxy. The 200 OK response notifies the backup proxy that User B has received the BYE request.
21.	200 OK—Backup proxy to Cisco SIP IP phone (User A)	Backup proxy sends a SIP 200 OK response to User A. The 200 OK response notifies User A that the backup proxy has received the BYE request.

## Call from a Cisco SIP IP Phone to a Gateway Acting as an Emergency Proxy

Figure B-22 illustrates a successful call from a Cisco SIP IP phone to a gateway acting as an emergency proxy.

**Figure B-22 A Successful Call from Cisco SIP IP Phone to Gateway (Emergency Proxy)**

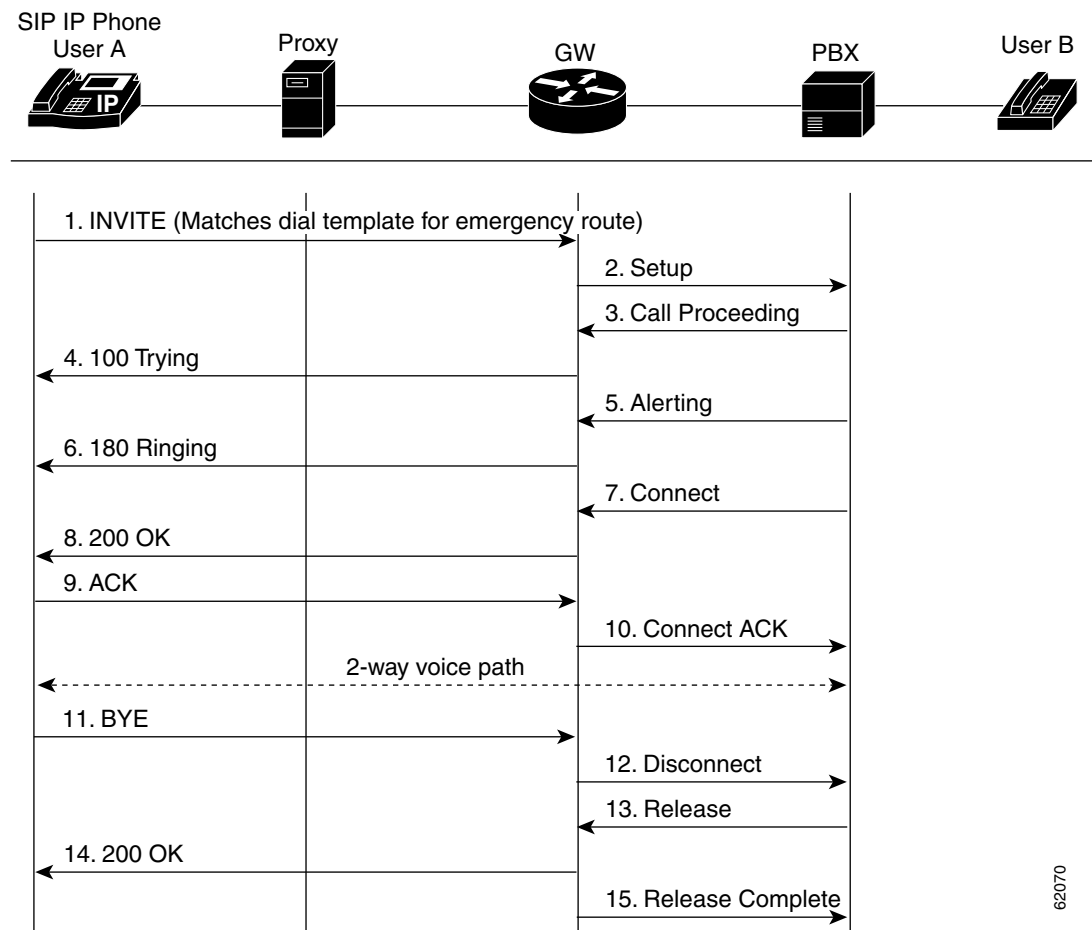

62070

Step	Action	Description
1.	INVITE—Cisco SIP IP phone to gateway (emergency proxy)	Cisco SIP IP phone tries to connect to the gateway (emergency proxy) by sending out the INVITE message. The dial template for the emergency route is matched.
2.	Setup—Gateway to PBX	Call setup is initiated between the gateway and PBX. The call setup includes the standard transactions that take place as User A attempts to call User B.
3.	Call Proceeding—PBX to gateway	PBX sends a Call Proceeding message to gateway to acknowledge the Call Setup request.
4.	100 Trying—Gateway to Cisco SIP IP phone (User A)	Gateway sends a SIP 100 Trying response to User A. The 100 Trying response indicates that the INVITE request has been received by the gateway.
5.	Alerting—PBX to gateway	PBX sends an Alert message to the gateway. The Alert message indicates that the PBX has received a 100 Trying Ringing response from the gateway.
6.	180 Ringing—Gateway to Cisco SIP IP phone (User A)	The gateway sends a SIP 180 Ringing response to User A. The 180 Ringing response indicates that the gateway is being alerted.
7.	Connect—PBX to gateway	PBX sends a Connect message to gateway. The Connect message notifies the gateway that the connection has been made.
8.	200 OK—Gateway to Cisco SIP IP phone (User A)	Gateway sends a SIP 200 OK response to the User A. The 200 OK response notifies User A that the connection has been made.
9.	ACK—Cisco SIP IP phone (User A) to gateway	User A sends a SIP ACK to the gateway. The ACK confirms that User A has received the 200 OK response. The call session is now active.
10.	Connect ACK—Gateway to PBX	Gateway acknowledges PBX's Connect message.
11.	BYE—Cisco SIP IP phone (User A) to gateway	User A terminates the call session and sends a SIP BYE request to gateway. The BYE request indicates that User A wants to release the call.
12.	Disconnect—Gateway to PBX	Gateway sends a Disconnect message to PBX.
13.	Release—PBX to gateway	PBX sends a Release message to the gateway.
14.	200 OK—Gateway to Cisco SIP IP phone (User A)	Gateway sends a SIP 200 OK response to User A. The 200 OK response notifies User A that the gateway has received the BYE request.
15.	Release Complete—Gateway to PBX	Gateway sends a Release Complete message to the PBX and the call session is terminated.

## Call from a Cisco SIP IP Phone to a Cisco SIP IP Phone via Emergency Proxy

Figure B-23 illustrates a successful call from a Cisco SIP IP phone to a Cisco SIP IP phone via emergency proxy. User B is the extension of the dial template with the “Route” attribute as “emergency” in the dialplan.xml file.

Figure B-23 A Successful Call from a Cisco SIP IP Phone to a Cisco SIP IP Phone via Emergency Proxy

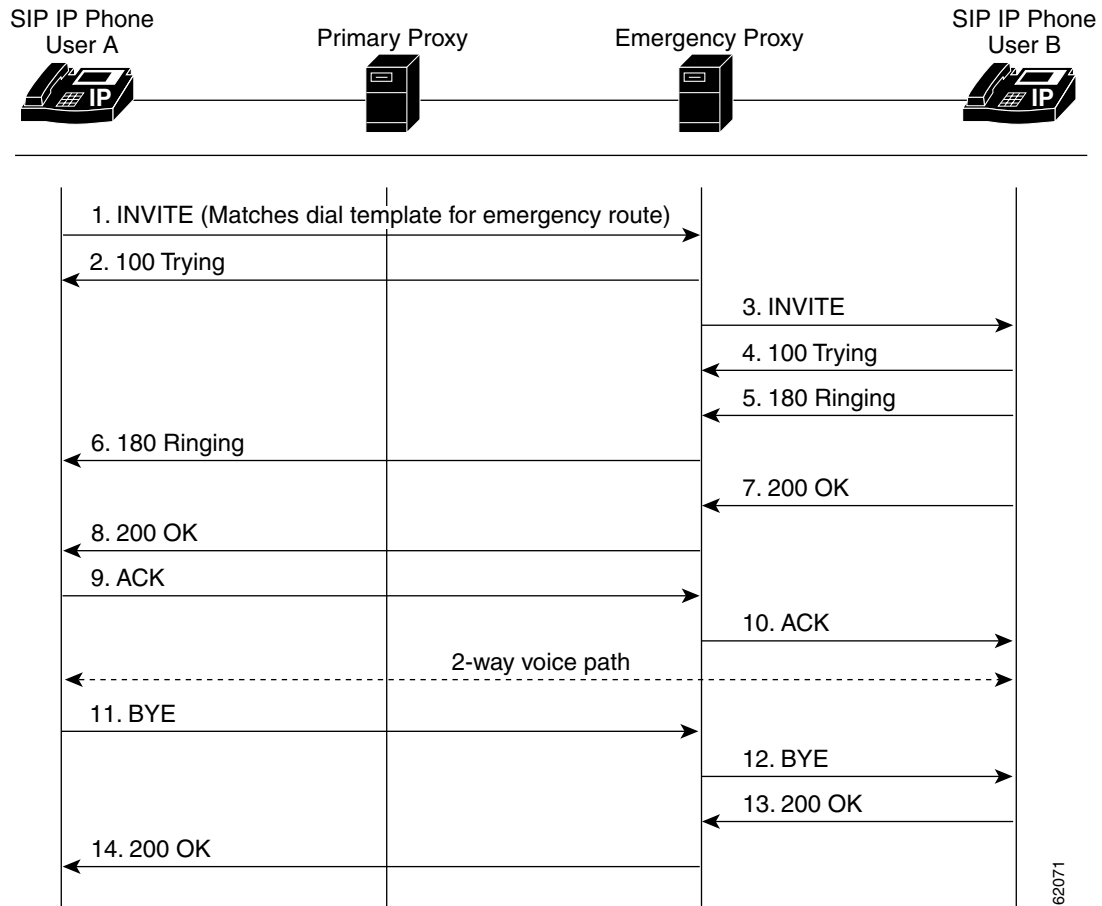

Step	Action	Description
1.	INVITE—Cisco SIP IP phone (User A) to emergency proxy	Cisco SIP IP phone tries to connect to the emergency proxy by sending out the INVITE message. The dial template for the emergency route is matched.
2.	100 Trying—Emergency proxy to Cisco SIP IP phone (User A)	Emergency proxy sends a SIP 100 Trying response to User A. The 100 Trying response indicates that the INVITE request has been received by the emergency proxy.
3.	INVITE—Emergency proxy to Cisco SIP IP phone (User B)	Backup proxy tries to connect to User B by sending out the INVITE message.
4.	100 Trying—Cisco SIP IP phone (User B) to emergency proxy	User B sends a SIP 100 Trying response to the emergency proxy. The 100 Trying response indicates that the INVITE request has been received by User B.
5.	180 Ringing—Cisco SIP IP phone (User B) to emergency proxy	User B sends a SIP 180 Ringing response to the emergency proxy. The 180 Ringing response indicates that User B is being alerted.
6.	180 Ringing—Emergency proxy to Cisco SIP IP phone (User A)	The emergency proxy sends a SIP 180 Ringing response to User A. The 180 Ringing response indicates that the emergency proxy is being alerted.
7.	200 OK—Cisco SIP IP phone (User B) to emergency proxy	User B sends a SIP 200 OK response to the emergency proxy. The 200 OK response notifies the emergency proxy that the connection has been made.

Step	Action	Description
8.	200 OK—Emergency proxy to Cisco SIP IP phone (User A)	Emergency proxy sends a SIP 200 OK response to User A. The 200 OK response notifies User A that the connection has been made.
9.	ACK—Cisco SIP IP phone (User A) to emergency proxy	User A acknowledges the emergency proxy's Connect message.
10.	ACK—Emergency proxy to Cisco SIP IP phone (User B)	Emergency proxy acknowledges User B's Connect message.
11.	BYE—Cisco SIP IP phone (User A) to emergency proxy	User A terminates the call session and sends a SIP BYE request to the emergency proxy. The BYE request indicates that User A wants to release the call.
12.	BYE—Emergency proxy to Cisco SIP IP phone (User B)	Emergency proxy terminates the call session and sends a SIP BYE request to User B. The BYE request indicates that the emergency proxy wants to release the call.
13.	200 OK—Cisco SIP IP phone (User B) to emergency proxy	User B sends a SIP 200 OK response to the emergency proxy. The 200 OK response notifies the emergency proxy that User B has received the BYE request.
14.	200 OK—Emergency proxy to Cisco SIP IP phone (User A)	Emergency proxy sends a SIP 200 OK response to User A. The 200 OK response notifies User A that the emergency proxy has received the BYE request.





## Technical Specifications

---

The following sections describe the technical specifications for the Cisco SIP IP phone:

- Physical and Operating Environment Specifications, page C-1
- Cable Specifications, page C-2
- Regulatory Safety Compliance, page C-2
- Connections Specifications, page C-3

## Physical and Operating Environment Specifications

The following table lists the physical and operating specifications of the Cisco SIP IP phone.

**Table C-1** Cisco SIP IP Phone Operational and Physical Specifications

Specification	Value or Range
Operating temperature	32 to 104 ° F (0 to 40 ° C)
Operating relative humidity	10 to 95% (noncondensing)
Storage temperature	14 ° to 140 ° F (-10 to 60 ° C)
Height	8 in. (20.32 cm)
Width	10.5 in. (26.67 cm)
Depth	6 in. (15.24 cm)
Weight	3.5 lb (1.6 kg)
Power	100-240 VAC, 50-60 Hz, 0.5 A—when using the AC adaptor 48 Vdc, 0.2 A—when using the in-line power over the network cable
Cables	Two (2) pair of Category 3 for 10 Mbps cables Two (2) pair of Category 5 for 100 Mbps cables
Distance Requirements	As supported by the Ethernet Specification, it is assumed that most sets that are deployed in the field will be within 100 m (330 ft.) of a phone closet.

# Cable Specifications

The following cables are required to connect the Cisco SIP IP phone:

- RJ-11 for the handset connection
- RJ-45 jack for the LAN connection (labeled “10/100 SW”).
- RJ-45 jack for a second 10Base-T compliant connection (labeled “10/100 PC”).
- 48-volt power connector. The diameter of the center pin in the phone power jack (Switchcraft 712A) is .1 inches (2.5 mm). The center pin is positive (+) voltage. The miniature power plug required to mate with the power jack on the phone is a Switchcraft 760 or equivalent.

# Regulatory Safety Compliance

The Cisco IP Phone models 7960, 7940, and 7910 meet the following regulatory safety and compliance approvals:

- CE Marking
- Safety
  - UL1950
  - CSA C22.2 No. 950
  - EN 60950
  - IEC 60950
  - AS/NZS 3260
  - TS001
- EMC
  - AS/NZS 3548 Class B
  - VCCI Class B
  - FCC (47CFR) Part 15 Class B
  - EN 55022, Class B
- Telecom
  - IC CS-03
  - FCC (47CFR) Part 68

Figure C-1 contains the FCC Class B Declaration for the Cisco IP Phone 7960, 7940, 7910, and 7910+SW.



Figure C-1 FCC Class B Declaration



**DECLARATION OF CONFORMITY**  
according to ISO/IEC Guide 22

**Cisco Systems Inc.**  
170 West Tasman Drive  
San Jose, CA 95134  
USA

Declare under our sole responsibility that the product(s):

*Cisco IP Phone 7960, 7940, 7910, 7910+SW*

To which this declaration relates, is in conformity with the following standards and/or other normative documents.

**EMC 47 CFR Part 15, Oct. 1997 Class B**

Date of Issue: 21 August, 2000

**Signature:**

A handwritten signature in black ink that reads "Semyon Grozman".

**Semyon Grozman**  
**Regulatory Compliance Manager**  
**Enterprise Line of Business**

Additional information:

*EMC Test Report: ENG-55825*

**DofC 76598**  
**Revision 1**

## Connections Specifications

The Cisco SIP IP phone has two RJ-45 ports that each support 10/100 Mbps half- or full-duplex connections to external devices—the network port and access port. You can use either Category 3 or 5 cabling for 10 Mbps connections, but use Category 5 for 100 Mbps connections. On both the LAN-to-phone port (left RJ-45 port facing the back of the phone) and PC-to-phone port (right port), use full-duplex to avoid collisions. Use the LAN-to-phone port to connect the phone to the network a LAN-to-phone jack. Use the PC-to-phone port to connect a network device, such as a computer, to the phone.

For a diagram identifying the different ports on the back of the Cisco SIP IP phone, see the “Connecting the Phone” section on page 2-11.





## Translated Safety Warnings

---

This appendix repeats in multiple languages the warnings that appear in the “Getting Started with Your Cisco SIP IP Phone” chapter of this guide.

### Installation Warning



**Warning**

---

**Read the installation instructions before you connect the system to its power source.**

---

**Waarschuwing** Raadpleeg de installatie-aanwijzingen voordat u het systeem met de voeding verbindt.

**Varoitus** Lue asennusohjeet ennen järjestelmän yhdistämistä virtälähteeseen.

**Attention** Avant de brancher le système sur la source d'alimentation, consulter les directives d'installation.

**Warnung** Lesen Sie die Installationsanweisungen, bevor Sie das System an die Stromquelle anschließen.

**Avvertenza** Consultare le istruzioni di installazione prima di collegare il sistema all'alimentatore.

**Advarsel** Les installasjonsinstruksjonene før systemet kobles til strømkilden.

**Aviso** Leia as instruções de instalação antes de ligar o sistema à sua fonte de energia.

**¡Advertencia!** Ver las instrucciones de instalación antes de conectar el sistema a la red de alimentación.

**Varning!** Läs installationsanvisningarna innan du kopplar systemet till dess strömförsörjningsenhet.

### Product Disposal Warning



**Warning**

---

**Ultimate disposal of this product should be handled according to all national laws and regulations.**

---

**Waarschuwing** Dit produkt dient volgens alle landelijke wetten en voorschriften te worden afgedankt.

**Varoitus** Tämän tuotteen lopullisesta hävittämisestä tulee huolehtia kaikkia valtakunnallisia lakeja ja säännöksiä noudattaen.

**Attention** La mise au rebut définitive de ce produit doit être effectuée conformément à toutes les lois et réglementations en vigueur.

**Warnung** Dieses Produkt muß den geltenden Gesetzen und Vorschriften entsprechend entsorgt werden.

**Avvertenza** L'eliminazione finale di questo prodotto deve essere eseguita osservando le normative italiane vigenti in materia.

**Advarsel** Endelig disponering av dette produktet må skje i henhold til nasjonale lover og forskrifter.

**Aviso** A descartagem final deste produto deverá ser efectuada de acordo com os regulamentos e a legislação nacional.

**¡Advertencia!** El desecho final de este producto debe realizarse según todas las leyes y regulaciones nacionales.

**Warning!** Slutlig kassering av denna produkt bör skötas i enlighet med landets alla lagar och föreskrifter.

## Lightning Activity Warning



Warning

---

**Do not work on the system or connect or disconnect cables during periods of lightning activity.**

---

**Waarschuwing** Tijdens onweer dat gepaard gaat met bliksem, dient u niet aan het systeem te werken of kabels aan te sluiten of te ontkoppelen.

**Varoitus** Älä työskentele järjestelmän parissa äläkä yhdistä tai irrota kaapeleita ukkosilmalla.

**Attention** Ne pas travailler sur le système ni brancher ou débrancher les câbles pendant un orage du foudre.

**Warnung** Arbeiten Sie nicht am System und schließen Sie keine Kabel an bzw. trennen Sie keine ab, wenn es gewittert.

**Avvertenza** Non lavorare sul sistema o collegare oppure scollegare i cavi durante un temporale con fulmini.

**Advarsel** Utfør aldri arbeid på systemet, eller koble kabler til eller fra systemet når det tordner eller lyner.

**Aviso** Não trabalhe no sistema ou ligue e desligue cabos durante períodos de mau tempo (trovoada).

**¡Advertencia!** No operar el sistema ni conectar o desconectar cables durante el transcurso de descargas eléctricas en la atmósfera.

**Warning!** Vid åska skall du aldrig utföra arbete på systemet eller ansluta eller koppla loss kablar.

## SELV Circuit Warning (other versions available)



Warning

---

**To avoid electric shock, do not connect safety extra-low voltage (SELV) circuits to telephone-network voltage (TNV) circuits. LAN ports contain SELV circuits, and WAN ports contain TNV circuits. Some LAN and WAN ports both use RJ-45 connectors. Use caution when connecting cables.**

---

**Waarschuwing** Om elektrische schokken te vermijden, mogen veiligheidscircuits met extra lage spanning (genaamd SELV = Safety Extra-Low Voltage) niet met telefoonnetwerkspanning (TNV) circuits verbonden worden. LAN (Lokaal netwerk) poorten bevatten SELV circuits en WAN (Regionaal netwerk) poorten bevatten TNV circuits. Sommige LAN en WAN poorten gebruiken allebei RJ-45 connectors. Ga voorzichtig te werk wanneer u kabels verbindt.

**Varoitus** Jotta vältty sähköiskulta, älä kytke pienjännitteisiä SELV-suojapiirejä puhelinverkkojännitettä (TNV) käyttäviin virtapiireihin. LAN-portit sisältävät SELV-piirejä ja WAN-portit puhelinverkkojännitettä käyttäviä piirejä. Osa sekä LAN- että WAN-porteista käyttää RJ-45-liittimiä. Ole varovainen kytkiessäsi kaapeleita.

**Attention** Pour éviter une électrocution, ne raccordez pas les circuits de sécurité basse tension (Safety Extra-Low Voltage ou SELV) à des circuits de tension de réseau téléphonique (Telephone Network Voltage ou TNV). Les ports du réseau local (LAN) contiennent des circuits SELV et les ports du réseau longue distance (WAN) sont munis de circuits TNV. Certains ports LAN et WAN utilisent des connecteurs RJ-45. Raccordez les câbles en prenant toutes les précautions nécessaires.

**Warnung** Zur Vermeidung von Elektroschock die Sicherheits-Kleinspannungs-Stromkreise (SELV-Kreise) nicht an Fernsprechnetzspannungs-Stromkreise (TNV-Kreise) anschließen. LAN-Ports enthalten SELV-Kreise, und WAN-Ports enthalten TNV-Kreise. Einige LAN- und WAN-Ports verwenden auch RJ-45-Steckverbinder. Vorsicht beim Anschließen von Kabeln.

**Avvertenza** Per evitare scosse elettriche, non collegare circuiti di sicurezza a tensione molto bassa (SELV) ai circuiti a tensione di rete telefonica (TNV). Le porte LAN contengono circuiti SELV e le porte WAN contengono circuiti TNV. Alcune porte LAN e WAN fanno uso di connettori RJ-45. Fare attenzione quando si collegano cavi.

**Advarsel** Unngå å koble lavspenningskretser (SELV) til kretser for telenettspenning (TNV), slik at du unngår elektrisk støt. LAN-utganger inneholder SELV-kretser og WAN-utganger inneholder TNV-kretser. Det finnes både LAN-utganger og WAN-utganger som bruker RJ-45-kontakter. Vær forsiktig når du kobler kabler.

**Aviso** Para evitar choques eléctricos, não conecte os circuitos de segurança de baixa tensão (SELV) aos circuitos de tensão de rede telefónica (TNV). As portas LAN contêm circuitos SELV e as portas WAN contêm circuitos TNV. Algumas portas LAN e WAN usam conectores RJ-45. Tenha o devido cuidado ao conectar os cabos.

**¡Advertencia!** Para evitar la sacudida eléctrica, no conectar circuitos de seguridad de voltaje muy bajo (safety extra-low voltage = SELV) con circuitos de voltaje de red telefónica (telephone network voltage = TNV). Los puertos de redes de área local (local area network = LAN) contienen circuitos SELV, y los puertos de redes de área extendida (wide area network = WAN) contienen circuitos TNV. En algunos casos, tanto los puertos LAN como los WAN usan conectores RJ-45. Proceda con precaución al conectar los cables.

**Varning!** För att undvika elektriska stötar, koppla inte säkerhetskretsar med extra låg spänning (SELV-kretsar) till kretsar med telefonnätspänning (TNV-kretsar). LAN-portar innehåller SELV-kretsar och WAN-portar innehåller TNV-kretsar. Vissa LAN- och WAN-portar är försedda med RJ-45-kontakter. Iaktta försiktighet vid anslutning av kablar.

## Circuit Breaker (15A) Warning



### Warning

**This product relies on the building's installation for short-circuit (overcurrent) protection. Ensure that a fuse or circuit breaker no larger than 120 VAC, 15A U.S. (240 VAC, 10A international) is used on the phase conductors (all current-carrying conductors).**

**Waarschuwing** Dit produkt is afhankelijk van de installatie van het gebouw voor kortsluit-(overstroom)beveiliging. Controleer of er een zekering of stroomverbreker van niet meer dan 120 Volt wisselstroom, 15 A voor de V.S. (240 Volt wisselstroom, 10 A internationaal) gebruikt wordt op de fasegeleiders (alle geleiders die stroom voeren).

**Varoitus** Tämä tuote on riippuvainen rakennukseen asennetusta oikosulkusuojauksesta (ylivirtasuojauksesta). Varmista, että vaihevirtajohtimissa (kaikissa virroitetuissa johtimissa) käytetään Yhdysvalloissa alle 120 voltin, 15 ampeerin ja monissa muissa maissa 240 voltin, 10 ampeerin sulaketta tai suojakytkintä.

**Attention** Pour ce qui est de la protection contre les courts-circuits (surtension), ce produit dépend de l'installation électrique du local. Vérifier qu'un fusible ou qu'un disjoncteur de 120 V alt., 15 A U.S. maximum (240 V alt., 10 A international) est utilisé sur les conducteurs de phase (conducteurs de charge).

**Warnung** Dieses Produkt ist darauf angewiesen, daß im Gebäude ein Kurzschluß- bzw. Überstromschutz installiert ist. Stellen Sie sicher, daß eine Sicherung oder ein Unterbrecher von nicht mehr als 240 V Wechselstrom, 10 A (bzw. in den USA 120 V Wechselstrom, 15 A) an den Phasenleitern (allen stromführenden Leitern) verwendet wird.

**Avvertenza** Questo prodotto dipende dall'installazione dell'edificio per quanto riguarda la protezione contro cortocircuiti (sovracorrente). Verificare che un fusibile o interruttore automatico, non superiore a 120 VCA, 15 A U.S. (240 VCA, 10 A internazionale) sia stato usato nei fili di fase (tutti i conduttori portatori di corrente).

**Advarsel** Dette produktet er avhengig av bygningens installasjoner av kortslutningsbeskyttelse (overstrøm). Kontroller at det brukes en sikring eller strømbryter som ikke er større enn 120 VAC, 15 A (USA) (240 VAC, 10 A internasjonalt) på faselederne (alle strømførende ledere).

**Aviso** Este produto depende das instalações existentes para protecção contra curto-circuito (sobrecarga). Assegure-se de que um fusível ou disjuntor não superior a 240 VAC, 10A é utilizado nos condutores de fase (todos os condutores de transporte de corrente).

**¡Advertencia!** Este equipo utiliza el sistema de protección contra cortocircuitos (o sobrecorrientes) del propio edificio. Asegurarse de que se utiliza un fusible o interruptor automático de no más de 240 voltios en corriente alterna (VAC), 10 amperios del estándar internacional (120 VAC, 15 amperios del estándar USA) en los hilos de fase (todos aquellos portadores de corriente).

**Warning!** Denna produkt är beroende av i byggnaden installerat kortslutningskydd (överströmsskydd). Kontrollera att säkring eller överspänningskydd används på fasledarna (samtliga strömförande ledare) för internationellt bruk max. 240 V växelström, 10 A (i USA max. 120 V växelström, 15 A).

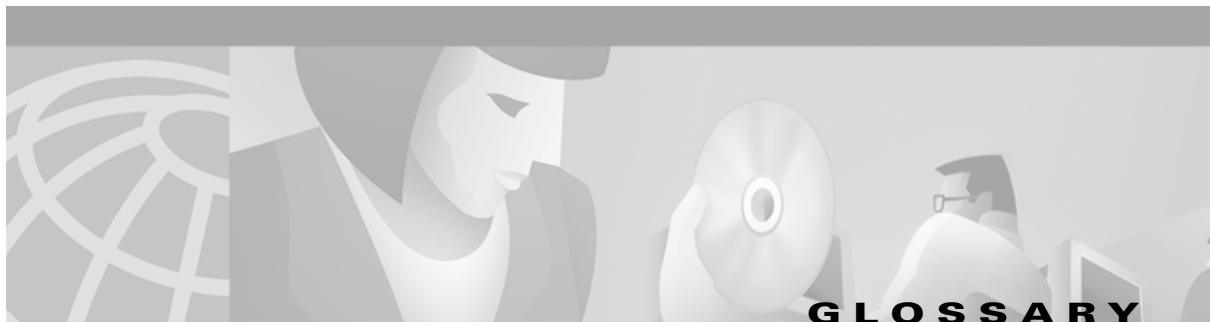

---

## **A**

### **AAA**

Authentication, Authorization, and Accounting. AAA is a suite of network security services that provides the primary framework through which access control can be set up on your Cisco router or access server.

### **ANI**

Automatic number identification.

---

## **C**

### **CAS**

Channel associated signaling.

### **CCAPI**

Call control applications programming interface.

### **CLI**

Command line interface.

### **CO**

Central office.

### **CPE**

Customer premises equipment. Terminating equipment, such as terminals, telephones, and modems, supplied by the telephone company, installed at the customer sites, and connected to the telephone company network.

### **CSM**

Call switching module.

---

## **D**

### **dial peer**

An addressable call endpoint. In Voice over IP (VoIP), there are two types of dial peers: POTS and VoIP.

**DNS**

Domain name system used to address translation to convert H.323 IDs, URLs, or e-mail IDs to IP addresses. DNS is also used to assist in the locating remote gatekeepers and to reverse-map raw IP addresses to host names of administrative domains.

**DNIS**

Dialed number identification service (the called number).

**DSP**

Digital signal processor.

**DTMF**

Dual tone multi-frequency.

---

**E****E.164**

The international public telecommunications numbering plan. A standard set by ITU-T which addresses telephone numbers.

**E&M**

Ear and mouth RBS signaling.

**endpoint**

A SIP terminal or gateway. An endpoint can call and be called. It generates and/or terminates the information stream.

---

**G****gateway**

A gateway allows SIP or H.323 terminals to communicate with terminals configured to other protocols by converting protocols. A gateway is the point where a circuit-switched call is encoded and repackaged into IP packets.

---

**H****H.323**

An International Telecommunication Union (ITU-T) standard that describes packet-based video, audio, and data conferencing. H.323 is an umbrella standard that describes the architecture of the conferencing system and refers to a set of other standards (H.245, H.225.0, and Q.931) to describe its actual protocol.

**H.323 RAS**

Registration, admission, and status. The RAS signaling function performs registration, admissions, bandwidth changes, status and disengage procedures between the VoIP gateway and the gatekeeper.



---

**I****IVR**

Integrated voice response. When someone dials in, IVR responds with a prompt to get a personal identification number (PIN), and so on.

---

**L****LEC**

Local exchange carrier.

**Location Server**

A SIP redirect or proxy server uses a location service to get information about a caller's location(s). Location services are offered by location servers.

---

**M****MF**

Multi-frequency tones are made of six frequencies that provide 15 two frequency combinations for indication digits 0-9 and KP/ST signals.

**multicast**

A process of transmitting PDUs from one source to many destinations. The actual mechanism (that is, IP multicast, multi-unicast, and so forth) for this process might be different for LAN technologies.

**multipoint-unicast**

A process of transferring PDUs (Protocol Data Units) where an endpoint sends more than one copy of a media stream to different endpoints. This can be necessary in networks which do not support multicast.

---

**N****node**

A H.323 entity that uses RAS to communicate with the gatekeeper, for example, an endpoint such as a terminal, proxy, or gateway.

---

**P****PDU**

Protocol data units used by bridges to transfer connectivity information.

**POTS**

Plain old telephone service. Basic telephone service supplying standard single line telephones, telephone lines, and access to the PSTN.

**Proxy Server**

An intermediary program that acts as both a server and a client for the purpose of making requests on behalf of other clients. Requests are serviced internally or by passing them on, possibly after translation, to other servers. A proxy interprets, and, if necessary, rewrites a request message before forwarding it.

**PSTN**

Public switched telephone network. PSTN refers to the local telephone company.

---

**R****Redirect Server**

A redirect server is a server that accepts a SIP request, maps the address into zero or more new addresses and returns these addresses to the client. It does not initiate its own SIP request nor accept calls.

**Registrar**

A registrar is a server that accepts REGISTER requests. A registrar is typically co-located with a proxy or redirect server and MAY offer location services.

**RAS**

Registration, admission, and status protocol. This is the protocol that is used between endpoints and the gatekeeper to perform management functions.

**RBS**

Robbed bit signaling.

---

**S****SIP**

Session Initiation Protocol. This is a protocol developed by the IETF MMUSIC Working Group as an alternative to H.323. SIP features are compliant with IETF RFC 2543, published in March 1999.

SIP equips platforms to signal the setup of voice and multimedia calls over IP networks.

**SPI**

Service provider interface.

---

**T****TDM**

Time division multiplexing. Technique in which information from multiple channels can be allocated bandwidth on a single wire based on preassigned time slots. Bandwidth is allocated to each channel regardless of whether the station has data to transmit.

---

**U****User Agent**

See UAS.

**UAC**

User Agent Client: A user agent client is a client application that initiates the SIP request.

**UAS**

User Agent Server (or user agent): A user agent server is a server application that contacts the user when a SIP request is received, then returns a response on behalf of the user. The response accepts, rejects or redirects the request.

---

**V****VoIP**

Voice over IP. The ability to carry normal telephone-style voice over an IP-based Internet with POTs-like functionality, reliability, and voice quality. VoIP is a blanket term, which generally refers to Cisco's standards based (for example H.323) approach to IP voice traffic.





---

## Numerics

- 10/100 PC port **1-11**
- 10/100 SW port **1-11**
- 1xx responses **A-2**
- 2xx responses **A-3**
- 3xx responses **A-3**
- 4xx responses **A-4**
- 5xx responses **A-6**
- 6xx responses **A-7**

---

## A

- Accept-Encoding header field **A-7**
- Accept header field **A-7**
- Accept-Language header field **A-7**
- accessing
  - firmware version **3-37**
  - network statistics **3-36**
  - status messages **3-36**
- access port **1-11**
- address
  - proxy server **3-23**
  - TFTP server **3-4**
- adjusting, phone placement **2-12**
- administrative VLAN ID parameter **3-3**
- Allow header field **A-7**
- Also header field **A-7**
- alternate TFTP server, enabling **3-3**
- authentication
  - name, configuring **3-20**
  - services **1-2**
- Authorization header field **A-7**

---

## B

- billing services **1-2**
- book
  - objectives **viii**
  - organization **viii**
- buttons
  - information **1-4**
  - line **1-4**
  - volume **1-4**

---

## C

- cables
  - connecting **2-11**
  - specifications **C-2**
- Caller ID blocking **1-7**
- call flows **B-1**
  - successful **B-1**
  - unsuccessful **B-46**
- call forward **1-7**
- call hold **1-7**
- Call-ID header field **A-7**
- call transfer **1-7**
- call waiting disabled **1-6**
- call waiting enabled **1-6**
- circuit breaker (15A) warning **D-4**
- clients
  - gateways **1-3**
  - phones **1-3**
  - SIP **1-3**
- codec, specifying **3-15, 3-24**
- common parameters **3-7**

compliance information **A-1**  
 configuration, erasing **3-4**  
 configuration files  
   default  
     creating **2-5**  
     example **3-19**  
     modifying **3-8**  
   guidelines **2-4**  
   phone-specific **2-4, 2-7**  
     creating **2-6**  
     example **3-21**  
     modifying **3-19**  
     naming convention **2-4**  
   SIPDefault.cnf **2-5**  
   storing **2-5**  
 configuration mode  
   entering into **3-2**  
   locking **3-2**  
   unlocking **3-2**  
 configuring  
   lines  
     authentication name **3-20**  
     name **3-20**  
     password **3-20**  
     short name **3-20**  
   network parameters **2-9**  
     manually **2-10**  
     via DHCP **2-10**  
   SIP parameters  
     manually **2-7**  
     via TFTP **2-4**  
 connections **1-10, 2-11**  
 Contact header field **A-7**  
 Content-Encoding header field **A-7**  
 Content-Length header field **A-7**  
 Content-Type header field **A-7**  
 conventions, document **ix**  
 Cseq header field **A-7**

---

## D

Date header field **A-7**  
 default configuration file **2-4, 2-5**  
   example **2-6, 3-19**  
   guidelines **2-4**  
   modifying **3-8**  
   SIPDefault.cnf **2-3**  
 default router parameters **3-3**  
 DHCP  
   description **1-9**  
   enabling **3-3**  
   options  
     default IP gateway **2-10**  
     DNS server **2-10**  
     domain name **2-10**  
     IP address **2-10**  
     IP subnet mask **2-10**  
     TFTP server **2-10**  
   releasing address **3-3**  
   server parameter **3-3**  
 dialing pad **1-4**  
 directory services **1-2**  
 DNS  
   description **1-9**  
   server parameters **3-3**  
 documentation  
   conventions **ix**  
   related **viii**  
 domain name parameter **3-3**  
 Domain Name System (DNS) **1-9**  
 do not disturb **1-6**  
 downloading required files **2-3**  
 DTMF  
   DB level **3-13**  
   inband **3-13**  
   outofband **3-13, 3-24**  
   payload **3-12**  
 Dynamic Host Control Protocol (DHCP) **1-9**

---

**E**

## enabling

- alternate TFTP server **3-3**
- DHCP **3-3**
- registration **3-16, 3-24**

Encryption header field **A-7**endpoint, SIP **1-2**

## erasing

- configuration **3-4**
- parameters **3-35**
- settings **3-35**

## example

- default configuration file **3-19**
- phone-specific configuration file **3-21**

Expires header field **A-7**

---

**F**

## features

- call forward **1-7**
- call hold **1-7**
- call transfer **1-7**
- call waiting disabled **1-6**
- call waiting enabled **1-6**
- do not disturb **1-6**
- secondary directory number **1-6**
- URL dialing **1-7**

## file

- default **3-19**
- phone-specific **3-21**

## files

- audio **2-3**
- dual boot **2-3**
- firmware image **2-3**
- OS79XX.txt **2-3**
- RINGLIST.DAT **2-3**
- SIPDefault.cnf **2-3**

## firmware

image **2-3**updating **3-38**version, viewing **3-37**footstand adjustment **1-4**From header field **A-7**

## functions

- proxy server **A-1**
- redirect server **A-1**
- UAC **A-1**
- UAS **A-1**

---

**G**gateways **1-3**guidelines **2-10**

---

**H**handset **1-4**header fields **A-7**

## headset

- supported types **1-12**
- using **1-12**

headset and speaker toggle **1-4**Hide header field **A-7**host name parameter **3-4**

---

**I**ICMP, description **1-9**image version **3-13**information button **1-4**initialization process **2-1**installation **2-2**

- downloading required files **2-3**
- network parameters **2-9**
- safety warnings **D-1, D-2**
- SIP parameters **2-3**

task summary 2-2

Internet Control Message Protocol (ICMP) 1-9

Internet Protocol (IP) 1-9

INVITE

- retransmission expiration 3-17

IP

- address parameter 3-4
- description 1-9

---

## K

keys

- on-screen mode 1-4
- scroll 1-4
- soft 1-4

---

## L

LCD screen 1-4

line buttons 1-4

lines, configuring

- authentication name 3-20
- name 3-20
- password 3-20
- short name 3-20

linex\_authname parameter 3-20

linex\_name parameter 3-20

linex\_password parameter 3-20

linex\_shortname parameter 3-20

locking, configuration mode 3-2

---

## M

MAC address parameter 3-4

Max-Forwards header field A-7

messages, status 3-36

messages URI parameter 3-24

Message Waiting Indication 1-6

methods

- ACK A-2
- BYE A-2
- CANCEL A-2
- INVITE A-2
- OPTIONS A-2
- REGISTER A-2

modifying

- network parameters 3-2, 3-3
- SIP parameters 3-8, 3-19

mute toggle 1-4

---

## N

name, configuring 3-20

naming convention, phone-specific configuration file 2-4

NAT 3-14

network

- connections 1-11
- parameters
  - administrative VLAN ID 3-3
  - alternate TFTP 3-3
  - configuring via DHCP 2-10
  - default router 3-3
  - DHCP address release 3-3
  - DHCP enable 3-3
  - DHCP server 3-3
  - domain name 3-3
  - erase configuration 3-4
  - guidelines 2-10
  - host name 3-4
  - IP address 3-4
  - MAC address 3-4
  - operational VLAN ID 3-4
  - subnet mask 3-4
  - TFTP server 3-4
- port 1-11
- statistics 3-36

network address translation (NAT) 3-14, 3-25



## network connections

access port 1-11

**O**

on-screen mode keys 1-4

operating environment specifications C-1

operational VLAN ID parameter 3-4

Organization header field A-7

OS79XX.txt 2-3

Out of Band DTMF parameter 3-24

## overview

Cisco SIP IP phone 1-3

initialization process 2-1

product 1-1

SIP 1-1

**P**

## parameters

common 2-5, 3-7

## configuring

network 2-9

SIP 2-3

erasing 3-35

nat\_enable 3-14

## network 2-9

administrative VLAN ID 3-3

alternate TFTP 3-3

default routers 3-3

DHCP address release 3-3

DHCP enable 3-3

DHCP server 3-3

DNS server 3-3

domain name 3-3

erase configuration 3-4

guidelines 2-10

host name 3-4

IP address 3-4

MAC address 3-4

modifying 3-2, 3-3

operational VLAN ID 3-4

subnet mask address 3-4

TFTP server 3-4

required 2-7

## SIP

Authentication Name 3-22

Authentication Password 3-23

dtmf\_avt\_payload 3-12

dtmf\_db\_level 3-13

dtmf\_outofbound 3-13

image\_version 3-13

linex\_authname 3-20

linex\_name 3-20

linex\_password 3-20

linex\_shortname 3-20

Messages URI 3-24

Name 3-22

Out of Band DTMF 3-24

Preferred Codec 3-24

preferred\_codec 3-15

proxy\_register 3-16

proxy1\_address 3-16

proxy1\_port 3-16

Proxy Address 3-23

Proxy Port 3-23

Register Expires 3-24

Register with Proxy 3-24

required 2-6

Short Name 3-22

sip\_invite\_retx 3-17

sip\_retx 3-17

timer\_invite\_expires 3-17

timer\_register\_expires 3-18

timer\_t1 3-18

timer\_t2 3-18

tos\_media 3-18

- password
  - configuring **3-20**
  - line **3-20**
- phone **3-7**
  - adjusting placement **2-12**
  - connecting **2-11**
  - connections **1-10**
    - access port **1-11**
    - network **1-11**
    - network port **1-11**
  - features
    - dialing pad **1-4**
    - footstand adjustment **1-4**
    - handset **1-4**
    - headset **1-12**
    - headset and speaker toggle **1-4**
    - information button **1-4**
    - LCD screen **1-4**
    - line buttons **1-4**
    - mute toggle **1-4**
    - on-screen mode keys **1-4**
    - physical **1-4**
    - scroll key **1-4**
    - soft keys **1-4**
    - volume buttons **1-4**
  - installing **2-2**
  - interfaces **1-3**
  - mounting to wall **2-13**
  - overview **1-3**
  - prerequisites **1-10**
  - secondary directory number **1-6**
  - supported features **1-5**
  - supported protocols **1-9**
    - DHCP **1-9**
    - DNS **1-9**
    - ICMP **1-9**
    - IP **1-9**
    - RTP **1-9**
    - SDP **1-9**
    - SNTP **1-9**
    - TCP **1-9**
    - TFTP **1-10**
    - UDP **1-10**
  - SNTP **1-9**
  - TCP **1-9**
  - TFTP **1-10**
  - UDP **1-10**
  - URL dialing **1-7**
  - verifying startup **2-14**
- phone-specific configuration file
  - creating **2-7**
  - example **2-6, 3-21**
  - modifying **3-19**
- physical specifications **C-1**
- port
  - access **1-11**
  - network **1-11**
  - proxy server **3-23**
- power source
  - Cisco Catalyst switches **1-12**
  - external **1-11**
- prerequisites **1-10**
- Priority header field **A-7**
- product
  - overview **1-1**
- product disposal warning **D-1**
- protocols **1-9**
  - DHCP **1-9**
  - DNS **1-9**
  - ICMP **1-9**
  - IP **1-9**
  - RTP **1-9**
  - SDP **1-9**
  - SNTP **1-9**
  - TCP **1-9**
  - TFTP **1-10**
  - UDP **1-10**
- Proxy-Authenticate header field **A-7**
- Proxy-Authorization header field **A-8**
- proxy port
  - specifying **3-16**
- Proxy-Required header field **A-8**

proxy server **1-3**  
 address **3-23**  
 port **3-23**  
 registration, enabling **3-16, 3-24**  
 specifying **3-16**

---

## R

Real-Time Transport Protocol (RTP) **1-9**  
 Record-Route header field **A-8**  
 redirect server **1-3**  
 registrar server **1-3**  
 registration  
 enabling **3-16**  
 timer **3-18, 3-24**  
 related documentation **viii**  
 release, DHCP address **3-3**  
 request methods **B-1**  
 Require header field **A-8**  
 resetting  
 network statistics **3-37**  
 Response-Key header field **A-8**  
 responses **A-2**  
 global (6xx) **A-7**  
 information (1xx) **A-2**  
 redirection (3xx) **A-3**  
 request failure (4xx) **A-4**  
 server failure (5xx) **A-6**  
 successful (2xx) **A-3**  
 retransmission timers **3-18**  
 Retry-After header field **A-8**  
 RFC  
 2131 **1-9**  
 2543 **1-1, 1-3**  
 768 **1-10**  
 791 **1-9**  
 792 **1-9**  
 RINGLIST.DAT **2-3**  
 Route header field **A-8**

RTP, description **1-9**

---

## S

safety warnings, translated **D-1**  
 circuit breaker (15A) warning **D-4**  
 installation warning **D-1**  
 lightning activity warning **D-2**  
 product disposal warning **D-1**  
 SELV circuit warning **D-2**  
 scroll key **1-4**  
 SDP, description **1-9**  
 SDP, usage **A-8**  
 secondary directory number **1-6**  
 SELV circuit warning **D-2**  
 server  
 alternate TFTP **3-3**  
 proxy **1-3**  
 redirect **1-3**  
 registrar **1-3**  
 Server header field **A-8**  
 Session Description Protocol (SDP) **1-9**  
 settings, erasing **3-35**  
 short name, configuring **3-20**  
 Simple Network Time Protocol (SNTP) **1-9**  
 SIP  
 architecture **1-2**  
 call flows **B-1**  
 successful **B-1**  
 unsuccessful **B-46**  
 clients **1-2, 1-3**  
 gateways **1-3**  
 phones **1-3**  
 compliance information **A-1**  
 components **1-2**  
 UAC **1-2**  
 user agent server **1-2**  
 default configuration file, example **2-6**  
 dtmf\_inband **3-13**

- end point **1-2**
  - functions **A-1**
  - gateways **1-3**
  - header fields **A-7**
  - IP phone, overview **1-3**
  - methods **A-1, A-2**
  - overview **1-1**
  - parameters
    - Authentication Name **3-22**
    - Authentication Password **3-23**
    - configuring on your phone **3-22**
    - Message URI **3-24**
    - Name **3-22**
    - Out of Band DTMF **3-24**
    - phone-specific configuration file **2-4**
    - Preferred Codec **3-24**
    - Proxy Address **3-23**
    - Proxy Port **3-23**
    - Register Expires **3-24**
    - Register with proxy **3-24**
    - Short Name **3-22**
  - request methods **B-1**
  - responses **A-2**
    - global (6xx) **A-7**
    - information (1xx) **A-2**
    - redirection (3xx) **A-3**
    - request failure (4xx) **A-4**
    - server failure (5xx) **A-6**
    - successful (2xx) **A-3**
  - SDP usage **A-8**
  - servers
    - proxy **1-3**
    - redirect **1-3**
    - registrar **1-3**
  - services
    - authentication **1-2**
    - billing **1-2**
    - directory **1-2**
  - SIPDefault.cnf **2-3, 2-5**
  - SIP parameters **3-22**
    - configuring on your phone **3-22**
    - configuring via TFTP server **2-4**
  - SNTP, description **1-9**
  - soft keys **1-4**
  - specifications **C-1**
    - cable **C-2**
    - connections **C-3**
    - operating environment **C-1**
    - physical **C-1**
  - specifying **3-13**
    - codec **3-15, 3-24**
    - DTMF level **3-13**
    - DTMF payload **3-12**
    - DTMF signaling **3-13**
    - image version **3-13**
    - proxy port **3-16**
    - proxy server **3-16**
    - retransmission timers **3-18**
    - TOS media **3-18**
  - specifying out of bound **3-24**
  - startup, verifying **2-14**
  - statistics, network **3-36**
  - status information
    - accessing **3-36, 3-37**
  - Subject header field **A-8**
  - subnet mask parameter **3-4**
- 
- T**
- TCP, description **1-9**
  - technical specifications **C-1**
    - cablet **C-2**
    - operating environment **C-1**
    - physical **C-1**
  - TFTP, description **1-10**
  - TFTP server parameter **3-4**
  - timer
    - registration **3-18, 3-24**

- retransmission **3-18**
- timer\_t2 **3-18**
- timers, retransmission **3-18**
- Timestamp header field **A-8**
- toggle
  - headset and speaker **1-4**
  - mute **1-4**
- To header field **A-8**
- TOS media
  - specifying **3-18**
- traceroute command **3-31**
- translated safety warnings **D-1**
  - circuit breaker (15A) warning **D-4**
  - installation warning **D-1**
  - lightning activity warning **D-2**
  - product disposal warning **D-1**
  - SELV circuit warning **D-2**
- Transmission Control Protocol (TCP) **1-9**
- Trivial File Transfer Protocol (TFTP) **1-10**

---

## U

- UAC **1-2**
- UDP, description **1-10**
- unlocking, configuration mode **3-2**
- Unsupported header field **A-8**
- updating
  - firmware **3-38**
- URL dialing **1-7**
- user
  - agent server **1-2**
- User-Agent header field **A-8**
- User Datagram Protocol (UDP) **1-10**

---

## V

- verifying startup **2-14**
- Via header field **A-8**

- viewing firmware version **3-37**
- VLAN
  - administrative **3-3**
  - operational **3-4**
- volume
  - buttons **1-4**

---

## W

- wall mounting
  - phone **2-13**
- Warning header field **A-8**
- WWW-Authenticate header field **A-8**

