



## **Cisco CRS Routers 16-Slot Line Card Chassis Enhanced Router Installation Guide**

**First Published:** 2013-08-25

**Last Modified:** 2017-10-24

### **Americas Headquarters**

Cisco Systems, Inc.  
170 West Tasman Drive  
San Jose, CA 95134-1706  
USA  
<http://www.cisco.com>  
Tel: 408 526-4000  
800 553-NETS (6387)  
Fax: 408 527-0883

THE SPECIFICATIONS AND INFORMATION REGARDING THE PRODUCTS IN THIS MANUAL ARE SUBJECT TO CHANGE WITHOUT NOTICE. ALL STATEMENTS, INFORMATION, AND RECOMMENDATIONS IN THIS MANUAL ARE BELIEVED TO BE ACCURATE BUT ARE PRESENTED WITHOUT WARRANTY OF ANY KIND, EXPRESS OR IMPLIED. USERS MUST TAKE FULL RESPONSIBILITY FOR THEIR APPLICATION OF ANY PRODUCTS.

THE SOFTWARE LICENSE AND LIMITED WARRANTY FOR THE ACCOMPANYING PRODUCT ARE SET FORTH IN THE INFORMATION PACKET THAT SHIPPED WITH THE PRODUCT AND ARE INCORPORATED HEREIN BY THIS REFERENCE. IF YOU ARE UNABLE TO LOCATE THE SOFTWARE LICENSE OR LIMITED WARRANTY, CONTACT YOUR CISCO REPRESENTATIVE FOR A COPY.

The Cisco implementation of TCP header compression is an adaptation of a program developed by the University of California, Berkeley (UCB) as part of UCB's public domain version of the UNIX operating system. All rights reserved. Copyright © 1981, Regents of the University of California.

NOTWITHSTANDING ANY OTHER WARRANTY HEREIN, ALL DOCUMENT FILES AND SOFTWARE OF THESE SUPPLIERS ARE PROVIDED "AS IS" WITH ALL FAULTS. CISCO AND THE ABOVE-NAMED SUPPLIERS DISCLAIM ALL WARRANTIES, EXPRESSED OR IMPLIED, INCLUDING, WITHOUT LIMITATION, THOSE OF MERCHANTABILITY, FITNESS FOR A PARTICULAR PURPOSE AND NON-INFRINGEMENT OR ARISING FROM A COURSE OF DEALING, USAGE, OR TRADE PRACTICE.

IN NO EVENT SHALL CISCO OR ITS SUPPLIERS BE LIABLE FOR ANY INDIRECT, SPECIAL, CONSEQUENTIAL, OR INCIDENTAL DAMAGES, INCLUDING, WITHOUT LIMITATION, LOST PROFITS OR LOSS OR DAMAGE TO DATA ARISING OUT OF THE USE OR INABILITY TO USE THIS MANUAL, EVEN IF CISCO OR ITS SUPPLIERS HAVE BEEN ADVISED OF THE POSSIBILITY OF SUCH DAMAGES.

Any Internet Protocol (IP) addresses and phone numbers used in this document are not intended to be actual addresses and phone numbers. Any examples, command display output, network topology diagrams, and other figures included in the document are shown for illustrative purposes only. Any use of actual IP addresses or phone numbers in illustrative content is unintentional and coincidental.

Cisco and the Cisco logo are trademarks or registered trademarks of Cisco and/or its affiliates in the U.S. and other countries. To view a list of Cisco trademarks, go to this URL: <http://www.cisco.com/go/trademarks>. Third-party trademarks mentioned are the property of their respective owners. The use of the word partner does not imply a partnership relationship between Cisco and any other company. (1110R)

© 2017 Cisco Systems, Inc. All rights reserved.



## CONTENTS

---

### Preface

#### Preface xv

Audience xv

Documentation Conventions xv

Related Documentation xvii

Changes to This Document xvii

Obtaining Documentation and Submitting a Service Request xviii

---

### CHAPTER 1

#### Installation Roadmap Overview 1

Installation Roadmap 1

---

### CHAPTER 2

#### Cisco CRS 16-Slot Line Card Chassis Enhanced Router 3

Overview 3

Line Card Chassis Components 6

Main Features of the Cisco CRS Series Carrier Routing System 8

Chassis Overview 8

Slot Numbers 8

Chassis Cable Management 11

Chassis Exterior Components 11

Safety Guidelines 16

Preventing Electrostatic Discharge 17

---

### CHAPTER 3

#### Installing Power Components 19

Power Systems Overview 19

Basic Chassis Power Details 19

Bonding and Grounding Guidelines 20

DC Power Systems 24

Input-Power-Present LEDs 25

AC Power Systems	26
How to Install Power Components	27
Installing the Power A Bus Bar	27
Prerequisites	28
Required Tools and Equipment	28
Steps	28
What to Do Next	33
Installing the Upper Grille Support	33
Prerequisites	33
Required Tools and Equipment	33
Steps	33
What to Do Next	34
Installing the Unistruts	34
Prerequisites	35
Required Tools and Equipment	35
Steps	35
What to Do Next	36
Installing the Chassis Ground Cable	37
Prerequisites	37
Required Tools and Equipment	37
Steps	38
What to Do Next	42
Installing an AC or DC Power Shelf	42
Prerequisites	43
Required Tools and Equipment	44
Steps	44
What to Do Next	48
Installing AC or DC Power Shelf Wiring	48
Installing DC Power Shelf Wiring	48
Prerequisites	48
Required Tools and Equipment	49
Steps	49
What to Do Next	50
Installing DC Terminal Block Covers	51
Required Tools and Equipment	51



Steps	51
What To Do Next	52
Installing AC Power Cords	52
Prerequisites	53
Required Tools and Equipment	53
Steps	53
What To Do Next	54
Installing the Exhaust Air Deflector	55
Prerequisites	55
Required Tools and Equipment	55
Steps	55
What to Do Next	58
Installing an Alarm Module	58
Prerequisites	59
Required Tools and Equipment	59
Steps	59
What to Do Next	62
Installing a Power Module	63
Prerequisites	63
Required Tools and Equipment	63
Steps	64
What to Do Next	65
Installing a Power Module Slot Cover	65
Prerequisites	66
Required Tools and Equipment	66
Steps	66
What to Do Next	67
Power Up and Power Down a Chassis	68
Power Up a Chassis	69
Prerequisites	69
Steps	69
Power Down a Chassis	71
Steps	71

**Information About the Air Circulation Components 73**About the Fan Trays **73**About the Air Filter **75****How to Replace Air Circulation Components 75**Replacing a Fan Tray **75**Prerequisites **76**Required Tools and Equipment **76**Steps **76**What to Do Next **77**Replacing the Air Filter **78**Prerequisites **78**Required Tools and Equipment **78**Steps **78**What to Do Next **79**

---

**CHAPTER 5****Installing Exterior Cosmetic Components 81**Information About Exterior Cosmetic Components **81**Installing the Front (PLIM) Side Exterior Cosmetic Components **86**Prerequisites **86**Required Tools and Equipment **86**Steps **87**Installing the Rear (MSC) Side Cosmetic Components **97**Prerequisites **97**Required Tools and Equipment **97**Steps **97**Attaching the Upper Rear Air Grille and Rear Kick Plate Without Vertical Troughs **104**

---

**CHAPTER 6****Installing Line Cards, PLIMs, and Associated Components 109**About Installing and Removing Cards and Associated Components **109**Guidelines for Card Installation and Removal **110**About Impedance Carriers and Slot Covers **113**About Hard Drives and PCMCIA Cards **117**About Cable Management Brackets **118**Installing or Removing a Slot Cover **118**Installing a Slot Cover **119**

Prerequisites	119
Required Tools and Equipment	120
Steps	120
What to Do Next	120
Removing a Slot Cover	121
Prerequisites	121
Required Tools and Equipment	121
Steps	121
What to Do Next	122
Installing or Removing an Impedance Carrier	122
Installing an Impedance Carrier	122
Prerequisites	123
Required Tools and Equipment	124
Steps	124
What to Do Next	125
Removing an Impedance Carrier	125
Prerequisites	125
Required Tools and Equipment	125
Steps	125
What to Do Next	126
Installing an RP, PRP, or DRP Card	126
About Distributed Route Processors and Distributed Route Processor PLIMs	127
Installing an RP, PRP, or DRP Card	130
Prerequisites	133
Required Tools and Equipment	133
Steps	133
What to Do Next	137
Verifying the Installation of an RP, PRP, or DRP Card	137
Understanding the Alphanumeric LEDs	139
Troubleshooting the RP, PRP, or DRP Card	139
Installing a Fan Controller Card	140
Installing a Cisco CRS Series Enhanced 16-Slot Line Card Chassis Fan Controller Card	140
Prerequisites	141
Required Tools and Equipment	141
Steps	142

What to Do Next	144
Verifying the Installation of a Cisco CRS Series Enhanced 16-Slot Line Card Chassis Fan Controller Card	144
Understanding the Alphanumeric LEDs	145
Troubleshooting the Cisco CRS Series Enhanced 16-Slot Line Card Chassis Fan Controller Card	145
Installing a Switch Fabric Card	145
Installing a Switch Fabric Card	146
Prerequisites	148
Required Tools and Equipment	148
Steps	148
What to Do Next	151
Verifying the Installation of a Switch Fabric Card	151
Understanding the Alphanumeric LEDs	151
Troubleshooting the Switch Fabric Card	152
Installing a Line Card	152
Installing an MSC, FP, or LSP Line Card	152
Prerequisites	156
Required Tools and Equipment	156
Steps	156
What to Do Next	159
Verifying the Installation of an MSC, FP, or LSP Line Card	159
Understanding the Alphanumeric LEDs	160
Troubleshooting the MSC, FP, or LSP Card	160
Installing a PLIM	161
Installing a PLIM	161
Prerequisites	163
Required Tools and Equipment	163
Steps	163
What to Do Next	165
Verifying the Installation of a PLIM	166
Troubleshooting the PLIM	166
Installing a Card-Based Hard Drive	167
Prerequisites	167
Required Tools and Equipment	167

Steps	167
What to Do Next	168
Installing a PCMCIA Card	168
Prerequisites	169
Required Tools and Equipment	169
Steps	169
What to Do Next	170
Installing Optical Modules	170
Installing a Cable Management Bracket	171
Prerequisites	171
Required Tools and Equipment	171
Steps	171
What to Do Next	172

---

**CHAPTER 7****Removing Chassis Components 173**

Removing Line Cards, PLIMs and Associated Components	173
Removing a Switch Fabric Card	173
Prerequisites	176
Required Tools and Equipment	176
Steps	176
What to Do Next	178
Removing an MSC, FP, or LSP Line Card	178
Prerequisites	179
Required Tools and Equipment	179
Steps	180
What to Do Next	182
Removing a Fan Controller Card	182
Prerequisites	182
Required Tools and Equipment	182
Steps	183
What to Do Next	184
Removing an RP, PRP, or DRP Card	184
Prerequisites	185
Required Tools and Equipment	185
Steps	185

What to Do Next	186
Removing a PLIM	187
Prerequisites	187
Required Tools and Equipment	188
Steps	188
What to Do Next	190
Removing a Hard Drive	190
Prerequisites	190
Required Tools and Equipment	190
Steps	190
What to Do Next	191
Removing an RP PCMCIA Card	191
Prerequisites	192
Required Tools and Equipment	192
Steps	192
What to Do Next	193
Removing Optical Modules	193
Removing a Cable Management Bracket	193
Prerequisites	194
Required Tools and Equipment	194
Steps	194
What to Do Next	195
Removing the Rear (MSC) Side Cosmetic Components	195
Prerequisites	195
Required Tools and Equipment	195
Steps	196
Removing the Upper Rear Air Grille and Rear Kick Plate if Vertical Troughs Are Not Used	201
What to Do Next	203
Removing the Front (PLIM) Side Cosmetic Components	203
Prerequisites	203
Required Tools and Equipment	203
Steps	203
What to Do Next	211
Replacing Air Circulation Components	212

Information About the Air Circulation Components	212
About the Fan Trays	212
About the Air Filter	214
How to Replace Air Circulation Components	214
Replacing a Fan Tray	214
Prerequisites	214
Required Tools and Equipment	215
Steps	215
What to Do Next	217
Replacing the Air Filter	217
Prerequisites	217
Required Tools and Equipment	217
Steps	218
What to Do Next	218
Removing Power Components	218
Removing a Power Module Slot Cover	219
Prerequisites	219
Required Tools and Equipment	219
Steps	219
What to Do Next	220
Removing a Power Module	221
Prerequisites	221
Required Tools and Equipment	221
Steps	221
What to Do Next	222
Removing an Alarm Module	222
Prerequisites	222
Required Tools and Equipment	223
Steps	223
What to Do Next	225
Removing the Exhaust Air Deflector	225
Prerequisites	225
Required Tools and Equipment	225
Steps	225
What to Do Next	227

Removing AC or DC Power Shelf Wiring	227
Removing DC Power Shelf Wiring	227
Prerequisites	228
Required Tools and Equipment	228
Steps	228
What To Do Next	229
Removing AC Power Shelf Wiring	229
Prerequisites	229
Required Tools and Equipment	229
Steps	229
What To Do Next	230
Removing a Power Shelf	231
Prerequisites	231
Required Tools and Equipment	231
Steps	231
What to Do Next	233
Removing the Upper Grille Support	233
Prerequisites	233
Required Tools and Equipment	233
Steps	233
Removing the Chassis Ground Cable	234
Prerequisites	234
Required Tools and Equipment	235
Steps	235
Disconnecting the Power A Bus Bar	239
Prerequisites	239
Required Tools and Equipment	239
Steps	239
Converting from One Power System to the Other	242
Steps	242
What to Do Next	243

---

**CHAPTER 8****Upgrading Chassis Components 245**

Upgrading the Inlet Grille Screen	245
Required Tools and Equipment	245



Removing the Currently Installed Front Inlet Grille	246	
Prerequisites	246	
Steps	246	
Removing the Currently Installed Inlet Grille Frame Assembly	247	
Prerequisites	247	
Steps	247	
Installing the Inlet Grille Frame Assembly and Inlet Screen	248	
Prerequisites	249	
Steps	249	
Installing the Exhaust Baffle	250	
Removing the Currently Attached Upper Rear Grille	252	
Prerequisites	252	
Steps	252	
What to Do Next	253	
Removing the Upper Fan Tray	253	
Prerequisites	253	
Required Tools and Equipment	253	
Steps	254	
What to Do Next	254	
Installing the Exhaust Baffle	255	
Prerequisites	255	
Required Tools and Equipment	255	
Steps	255	
What to Do Next	259	
Reinstalling the Upper Fan Tray	260	
Prerequisites	260	
Required Tools and Equipment	260	
Steps	260	
What to Do Next	261	
<b>CHAPTER 9</b>	<b>Cisco CRS 16-Slot EC Line Card Chassis Specifications</b>	<b>263</b>
	Line Card Chassis Specifications	263
	Power Specifications	265
	Line Card Chassis Environmental Specifications	267
	Regulatory, Compliance, and Safety Specifications	268

---

**CHAPTER 10**

**Product IDs 269**

Chassis Product IDs 269

CRS Hardware Compatibility 272



## Preface

---

This preface explains the objectives, intended audience, and organization of *Cisco Carrier Routing System 16-Slot Line Card Chassis Enhanced Router Installation Guide* and describes the conventions that convey instructions and other information.

- [Audience, page xv](#)
- [Documentation Conventions, page xv](#)
- [Related Documentation, page xvii](#)
- [Changes to This Document, page xvii](#)
- [Obtaining Documentation and Submitting a Service Request, page xviii](#)

## Audience

This guide is intended for line card chassis installers and Cisco installation partners who are responsible for installing the Cisco CRS Series Enhanced 16-Slot Line Card Chassis components. The chassis installers are expected to have installed networking hardware in the past. No additional knowledge of routing or the Cisco IOS XR software is assumed.

## Documentation Conventions

This document uses the following conventions:

Convention	Description
<b>bold font</b>	Commands and keywords and user-entered text appear in <b>bold font</b> .
<i>Italic font</i>	Document titles, new or emphasized terms, and arguments for which you supply values are in <i>italic font</i> .
[ ]	Elements in square brackets are optional.
{x   y   z}	Required alternative keywords are grouped in braces and separated by vertical bars.

Convention	Description
[x   y   z]	Optional alternative keywords are grouped in brackets and separated by vertical bars.
string	A nonquoted set of characters. Do not use quotation marks around the string or the string will include the quotation marks.
<code>courier font</code>	Terminal sessions and information the system displays appear in <code>courier font</code> .
<i></i>	Indicates a variable for which you supply values, in context where italics cannot be used.
<>	Nonprinting characters such as passwords are in angle brackets.
[ ]	Default responses to system prompts are in square brackets.
!, #	An exclamation point (!) or a pound sign (#) at the beginning of a line of code indicates a comment line.

**Note**

*Means reader take note.* Notes contain helpful suggestions or references to material not covered in the manual.

**Tip**

*Means the following information will help you solve a problem.* The tips information might not be troubleshooting or even an action, but could be useful information, similar to a Timesaver.

**Caution**

*Means reader be careful.* In this situation, you might perform an action that could result in equipment damage or loss of data.

**Warning****IMPORTANT SAFETY INSTRUCTIONS**

This warning symbol means danger. You are in a situation that could cause bodily injury. Before you work on any equipment, be aware of the hazards involved with electrical circuitry and be familiar with standard practices for preventing accidents. Use the statement number provided at the end of each warning to locate its translation in the translated safety warnings that accompanied this device.

**SAVE THESE INSTRUCTIONS****Warning**

Statements using this symbol are provided for additional information and to comply with regulatory and customer requirements.

## Related Documentation

For complete planning, installation, and configuration information, refer to the following documents:

- [Cisco CRS Carrier Routing System 16-Slot Line Card Chassis Unpacking, Moving, and Securing Guide](#)
- [Cisco CRS Carrier Routing System 16-Slot Line Card Chassis Site Planning Guide](#)
- [Cisco CRS Carrier Routing System 16-Slot Line Card Chassis System Description](#)
- [Cisco CRS 3-Phase AC Power Distribution Unit Installation Guide](#)
- [Cisco CRS Fiber-Optic Cleaning Kit Quick Start Guide](#)
- [Cisco CRS Carrier Routing System Hardware Documentation Guide](#)
- [Cisco CRS Carrier Routing System 16-Slot Line Card Chassis Hardware Operations and Troubleshooting Guide](#)
- [Cisco CRS Carrier Routing System Regulatory Compliance and Safety Information](#)
- [Cisco CRS Carrier Routing System Ethernet Physical Layer Interface Module Installation Note](#)
- [Cisco CRS Carrier Routing System Packet-over-SONET/SDH Physical Layer Interface Module Installation Note](#)

For a complete listing of software documentation available, refer to *About Cisco IOS XR Software Documentation*, available online at

[http://cisco.com/en/US/products/ps5763/tsd\\_products\\_support\\_series\\_home.html](http://cisco.com/en/US/products/ps5763/tsd_products_support_series_home.html)

## Changes to This Document

The table lists the technical changes made to this document since it was first printed.

**Table 1: Changes to This Document**

Date	Change Summary
July 2014	Added support for new 2x100GE-FLEX-40 PLIM. Added updates to support the Cisco CRS-X 400G back-to-back and multishelf systems, which include new CRS-16-FC400/M switch fabric cards.
January 2014	Added updates to support the Cisco CRS-X, which includes new line cards, switch fabric cards, and PLIMs.
November 2013	Updates to procedures, specifications, and illustrations.
May 2012	Updates to procedures, specifications, and illustrations.

Date	Change Summary
October 2011	Initial release of the document.

## Obtaining Documentation and Submitting a Service Request

For information on obtaining documentation, using the Cisco Bug Search Tool (BST), submitting a service request, and gathering additional information, see *What's New in Cisco Product Documentation*, at: <http://www.cisco.com/c/en/us/td/docs/general/whatsnew/whatsnew.html>.

Subscribe to *What's New in Cisco Product Documentation*, which lists all new and revised Cisco technical documentation as an RSS feed and delivers content directly to your desktop using a reader application. The RSS feeds are a free service, and Cisco currently supports RSS Version 2.0.



# CHAPTER 1

## Installation Roadmap Overview

This chapter provides details on installation steps and references to prepare Cisco Carrier Routing System (CRS) 16-Slot Line Card Chassis (LCC) Enhanced Router for operation.

- [Installation Roadmap, page 1](#)

## Installation Roadmap

This table lists the steps to install the chassis component and prepare the Cisco CRS Enhanced 16-Slot Line Card Chassis (LCC) for operation. Use the table as a checklist to ensure that all components are properly installed in the correct order. For information about a task, see the appropriate section of this installation guide.

**Table 2: Overview of Installation Steps**

Installation Steps	Reference
1 Verify that the chassis is securely bolted to the floor.	Cisco CRS Enhanced 16-Slot Line Card Chassis Unpacking, Moving, and Securing Guide
1 Un-cradle and install the upper power shelf bus bar.	<a href="#">“Installing the Power A Bus Bar” section on page 3-9</a>
1 Remove the exhaust air deflector from the rear of the chassis.	<a href="#">“Removing the Exhaust Air Deflector” section on page 7-45</a>
1 Ground the chassis.	<a href="#">“Installing the Chassis Ground Cable” section on page 3-17 .</a>
1 Install both AC or DC power shelves in the chassis.	<a href="#">“Installing an AC or DC Power Shelf” section on page 3-20 .</a>

Installation Steps	Reference
1 Install AC cables or DC wiring on upper power shelf.	<a href="#">“Installing AC or DC Power Shelf Wiring” section on page 3-25 .</a>
1 Install AC cables or DC wiring on lower power shelf.	<a href="#">“Installing AC or DC Power Shelf Wiring” section on page 3-25 .</a>
1 Reinstall the exhaust air deflector.	<a href="#">“Installing the Exhaust Air Deflector” section on page 3-31</a>
1 Install alarm modules in both power shelves.	<a href="#">“Installing an Alarm Module” section on page 3-34 .</a>
1 Install power modules in both power shelves.	<a href="#">“Installing a Power Module” section on page 3-38 .</a>
1 Power up the chassis and verify basic chassis operation.	<a href="#">“Power Up a Chassis” section on page 3-43 .</a>
1 Install default or optional external cosmetic components on the front (PLIM) side of the chassis.	<a href="#">“Installing the Front (PLIM) Side Exterior Cosmetic Components” section on page 5-5</a>
1 Install external cosmetic components on the rear (MSC) side of the chassis.	<a href="#">“Installing the Rear (MSC) Side Cosmetic Components” section on page 5-16</a>
1 Install line cards and PLIMs and route cables.	Chapter 6, “Installing Line Cards, PLIMs, and Associated Components”

**Note**


---

For removal and replacement procedures, see [Chapter 7, “Removing Chassis Components.”](#)

---





# Cisco CRS 16-Slot Line Card Chassis Enhanced Router

---

This chapter provides an overview of the Cisco CRS 16-Slot Line Card Chassis Enhanced router, referred to as LCC in this document.

- [Overview, page 3](#)
- [Line Card Chassis Components, page 6](#)
- [Main Features of the Cisco CRS Series Carrier Routing System, page 8](#)
- [Chassis Overview, page 8](#)
- [Safety Guidelines, page 16](#)
- [Preventing Electrostatic Discharge, page 17](#)

## Overview

The 16 slots in the LCC can contain the following:

- Modular services cards (MSCs)
- Forwarding processor (FPs) cards
- Label switch processor (LSP) cards



---

**Note** MSCs, FPs, and LSPs are referred to as line cards.

---

- Associated physical layer interface modules (PLIMs)
- SPA Interface Processors (SIPs)

Each slot has the capacity of up to 400 gigabits per second (Gbps) ingress and 400 Gbps egress, for a total routing capacity per chassis of 12800 Gbps or 12.8 terabits per second (Tbps). (A terabit is 1 x 10<sup>12</sup> bits or 1000 gigabits.)

The LCC supports 40G, 140G, and 400G fabric cards, as follows:

- The Cisco CRS-1 Carrier Routing System uses fabric cards designed for 40 G operation (CRS-16-FC/S or CRS-16-FC/M cards).
- The Cisco CRS-3 Carrier Routing System uses fabric cards designed for 140G operation (CRS-16-FC140/S or CRS-16-FC140/M cards).
- The Cisco CRS-X Carrier Routing System uses fabric cards designed for 400G operation (CRS-16-FC400/S or CRS-16-FC400/M cards).

A mixture of 40G, 140G, and 400G fabric cards is not supported except during migration.

**Note**

---

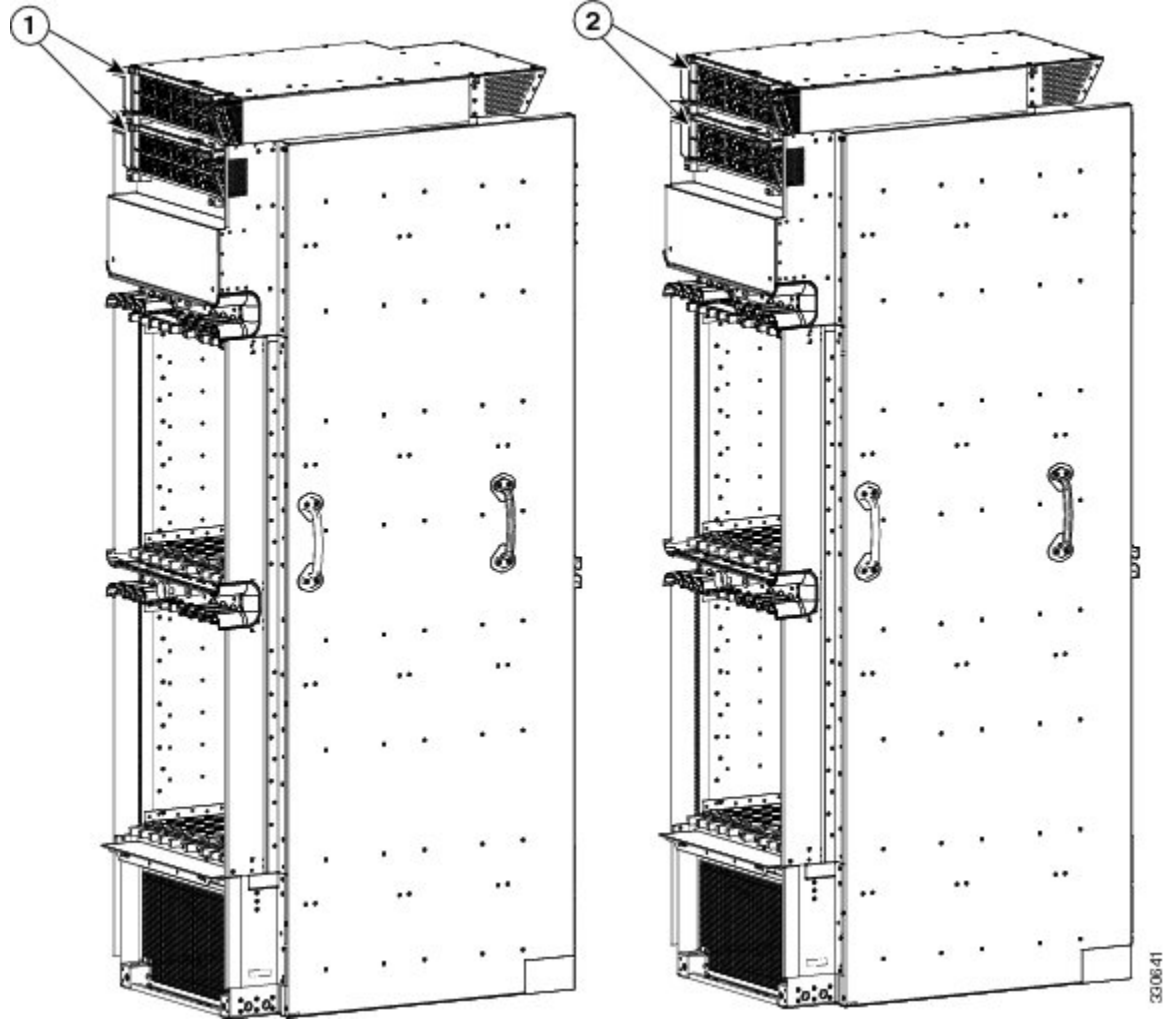
Throughout this document, the generic term Cisco CRS Carrier Routing system refers to the Cisco CRS-1, Cisco CRS-3, and Cisco CRS-X Carrier Routing Systems, unless otherwise specified.

---

The chassis has an integrated rack and does not require an external rack. It is bolted to the facility floor. It contains its own power and cooling systems. Power systems are available using AC or DC power.

Figure 1: LCC Front (PLIM) Side View , on page 5 shows the front view of the LCC with AC and DC power shelves installed.

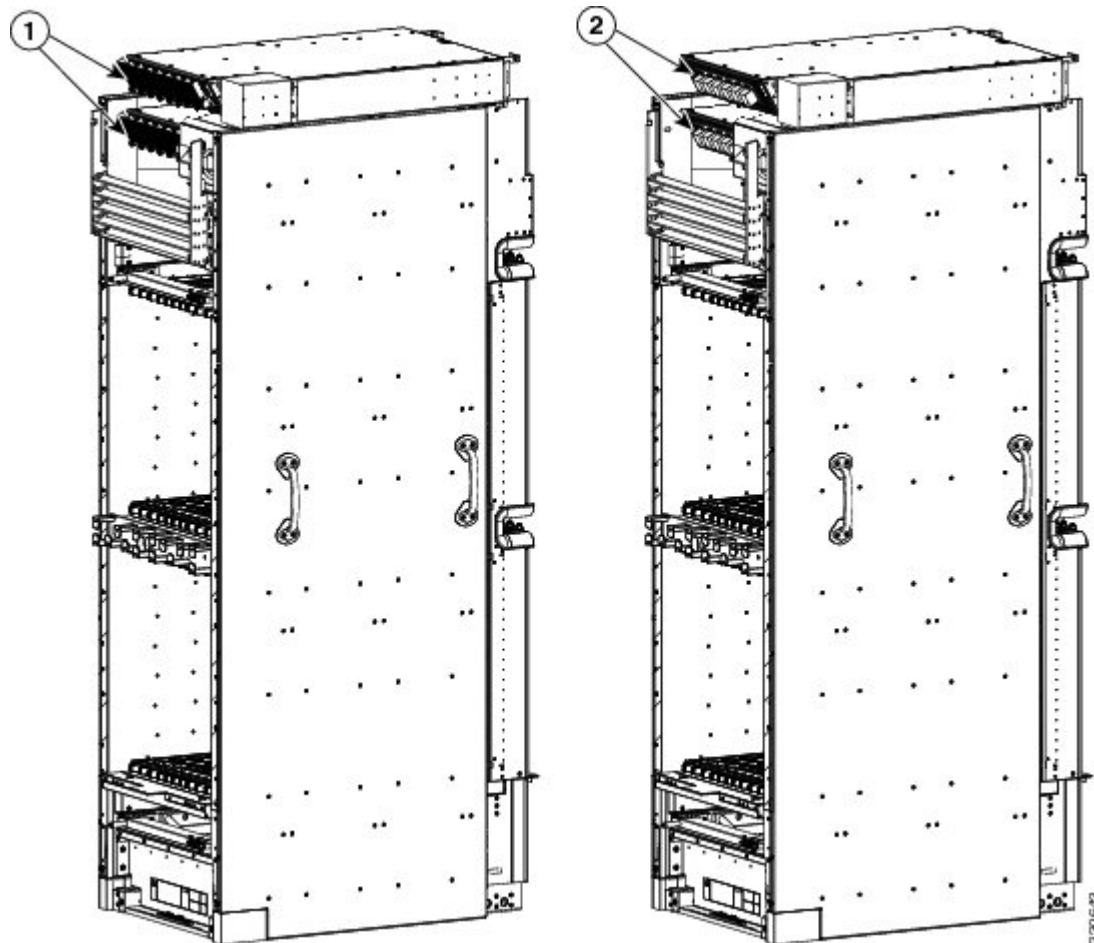
Figure 1: LCC Front (PLIM) Side View



1	DC power shelves (two installed, each shelf has eight power module slots)	2	AC power shelves (two installed, each shelf has six power module slots)
---	---	---	---

Figure 2: Line Card Chassis Rear (MSC) Side View, on page 6 shows the rear view of the LCC.

Figure 2: Line Card Chassis Rear (MSC) Side View



1	DC power shelves (two installed, each shelf has eight power module slots)	2	AC power shelves (two installed, each shelf has six power module slots)
---	---	---	---

## Line Card Chassis Components

This section lists the main components of the LCC. It primarily identifies the components that are considered field-replaceable units (FRUs), but where additional detail is useful, identifies subassemblies that are not field replaceable.

The line card chassis contains:

- As many as 16 MSCs, FPs, LSPs (all referred to as line cards) and associated PLIMs and SIPs/SPAs. A line card and a PLIM or SIP/SPA are an associated pair of cards that connect through the chassis

midplane. The line card provides the forwarding engine for Layer 3 routing of user data that is switched through the system, and the PLIM or SIP/SPA provides the physical interface and connectors for the user data.

**Note**

For a complete list of available PLIMs, consult your Cisco sales representative or visit: <http://www.cisco.com>

- - The MSC card is available in the following versions: CRS-MSC (end-of-sale), CRS-MSC-B, CRS-MSC-140G, and CRS-MSC-X (400G mode).
  - The FP card is available in the following versions: CRS-FP140, CRS-FP-X (400G mode).
  - The LSP card is available in the following versions: CRS-LSP, CRS-LSP-X.
- Each line card can be associated with different types of PLIMs, which provide different interface speeds and technologies. Note the following:
  - The CRS-MSC-B card is compatible with both 40G CRS-1 and 140G CRS-3 fabric cards.
  - The CRS-MSC-140G card is only compatible with the 140G CRS-3 fabric card.
  - The CRS-MSC-X card is only compatible with the 400G CRS-X fabric card.
- Chassis midplane. The midplane connects a line card to its associated PLIM. The midplane design allows the line card to be removed from the chassis without having to disconnect the cables that are attached to the associated PLIM. The midplane, which also distributes power, connects the line cards to the switch fabric cards, and provides control plane interconnections, is not field replaceable by the customer.
- Two route processor cards (RPs). The RPs provide the intelligence of the system by functioning as the chassis system controller. There are two types: RP and Performance Route Processor (PRP).

**Note**

A chassis may not be populated with a mix of RP and PRP cards. Both route processor cards should be of the same type (RP or PRP).

- Eight switch fabric cards. These fabric cards provide a three-stage Benes switch fabric for the system.
  - As a single-shelf (standalone) system, the line card chassis contains S123 switch fabric cards that provide all three stages of the three-stage Benes switch fabric.
  - As part of a multishelf system, the LCC contains S13 fabric cards that provide stage 1 and stage 3 of the switch fabric. S2 fabric cards in the FCCs provide stage 2 of the fabric, and fabric cables connect the fabric cards to each other.

**Note**

The LCC supports either 40G fabric cards (FC/S cards), 140G fabric cards (FC-140/S cards), or 400G fabric cards (FC-400/S cards). An LCC with a mix of 40G, 140G, and 400G fabric cards is not a supported mode of operation. Such a mode is temporarily allowed only during the upgrade process.

- A power system that provides redundant power to the chassis. Two types of power systems are available: either AC or DC power.
- Two alarm modules. The alarm modules provide external alarm system connections. The alarm modules are located in the AC or DC power shelves.
- Upper and lower fan trays. The trays push and pull air through the chassis. A removable air filter is located above the lower fan tray.
- Two fan controller cards. The cards control the speed of high-speed fans in the fan trays to adjust the airflow for ambient conditions.
- Front and rear cable management features. The front (PLIM) side of the chassis has horizontal cable management brackets above both card cages. The rear (MSC) side of the chassis has one cable management bracket located in the middle of the chassis above the lower card cage.

## Main Features of the Cisco CRS Series Carrier Routing System

The main features of all Cisco CRS Series routing systems include:

- A highly scalable router that provides a routing capacity between 1.28 and 12.8 Tbps.
- A wide range of interface speeds and types (for example, OC-48 packet-over-SONET or POS) and OC-192 POS), and a programmable MSC or FP forwarding engine that provides full-featured forwarding at line-rate speeds.
- Redundancy and reliability features allow nonstop operation even during service upgrades of equipment, with no single points of failure in hardware or software.
- Potential for expanding from single-chassis to multichassis (or multishelf) systems.
- Partitioning into logical routers. A logical router (LR) is a set of MSCs or FPs and route processors (RPs) that form a complete router. More specifically, each LR contains its own instance of dynamic routing, IP stack, SysDB (system database), interface manager, event notification system, and so on.

## Chassis Overview

This section provides an overview of the physical chassis characteristics:

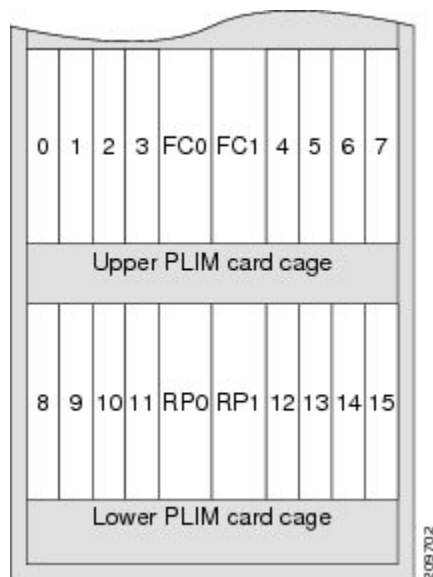
### Slot Numbers

A single-shelf (standalone) system consists of a single LCC. A multishelf system includes up to eight LCCs and connects up to four switch fabric card chassis.

This section identifies the locations of and slot numbers for major cards that plug into the chassis.

Figure 3: Line Card Chassis Front (PLIM) Side Slot Numbers, on page 9 shows the chassis slot numbers on the PLIM side of the LCC.

**Figure 3: Line Card Chassis Front (PLIM) Side Slot Numbers**

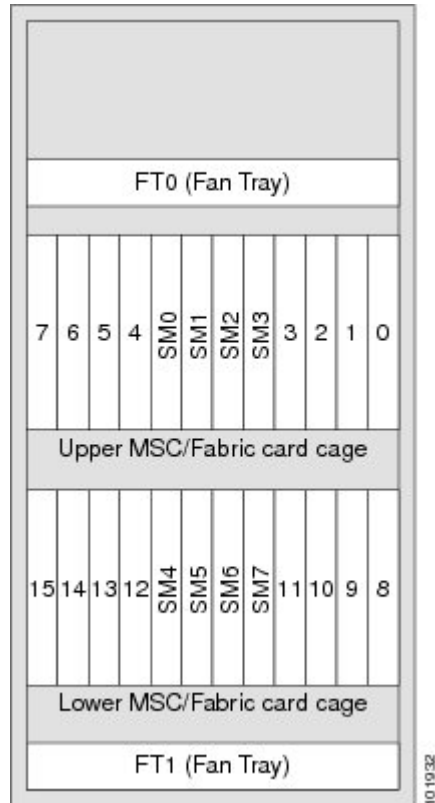


As shown in [Figure 3: Line Card Chassis Front \(PLIM\) Side Slot Numbers, on page 9](#), the components on the front (PLIM) side of the chassis include:

- Upper PLIM card cage with eight PLIM slots (left to right: 0, 1, 2, 3, 4, 5, 6, 7) spaced around two double-width fan controller card slots, FC0 and FC1. (These thicker-width slots accept only the two fan controllers.)
- Lower PLIM card cage with eight PLIM slots (left to right: 8, 9, 10, 11, 12, 13, 14, 15) and two double-width route processor card slots, RP0 and RP1. (These thicker-width slots accept only the RPs.)

Figure 4: Rear (MSC) Side Slot Numbers , on page 10 shows the chassis slot numbers on the rear (MSC) side of the LCC.

**Figure 4: Rear (MSC) Side Slot Numbers**



As shown in Figure 4: Rear (MSC) Side Slot Numbers , on page 10, the components on the rear (MSC) side of the chassis include:

- Upper fan tray (FT0)
- Upper card cage, eight MSC slots (left to right: 7, 6, 5, 4, 3, 2, 1, 0) spaced around four switch fabric card slots (SM0, SM1, SM2, and SM3)
- Lower card cage, eight MSC slots (left to right: 15, 14, 13, 12, 11, 10, 9, 8) spaced around four switch fabric card slots (SM4, SM5, SM6, and SM7)
- Lower fan tray (FT1)

The MSC slot numbers on the rear of the chassis are reversed from the PLIM slot numbers on the front side of the chassis. A mated MSC and PLIM are slot specific and mated through the midplane. The MSC slot 0, on the far right side of the chassis looking at it from the rear (MSC) side, is mated with the PLIM slot 0, on the far left side of the chassis looking at it from the front (PLIM) side. All other MSC and PLIM slots (2 through 15) are mated via matching slot numbers through the midplane also.



## Chassis Cable Management

The LCC has cable management features for both the front (PLIM) and rear (MSC) sides of the chassis. The PLIM side has horizontal cable management features above both card cages. The horizontal cable management trays have a special telescoping feature that allows them to be extended when the chassis is upgraded with higher-density cards. This extension feature also helps when installing the cables in the chassis. Ensure that the horizontal cable management trays are pushed in before closing the front door.

There are two types of vertical cable troughs as part of the chassis cable management: standard (default) width and (wide) width.

The MSC side of the chassis has one cable management system above the lower card cage (in the middle of the chassis). These cable management trays are not telescoping because there is a preset amount of fiber cabling to be managed.

## Chassis Exterior Components

This section contains information about the exterior cosmetic components.

The LCC is shipped with exterior cosmetic components for the front (PLIM) side and rear (MSC) side of the chassis.

**Note**

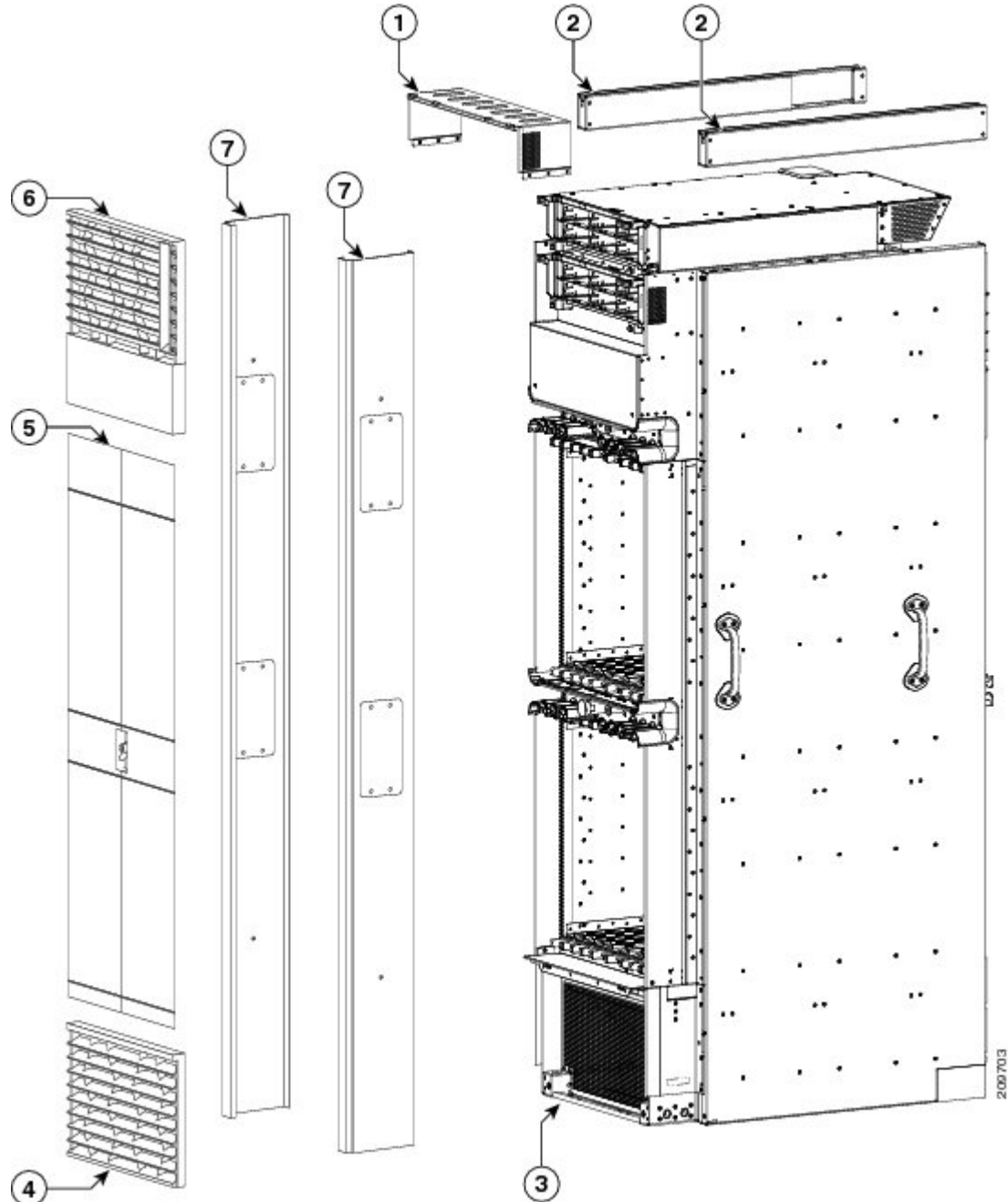
---

Some exterior cosmetic components are not required to be installed.

---

Figure 5: Front (PLIM) Side Exterior Cosmetic Components , on page 12 shows the exterior cosmetics for the front (PLIM) side of a chassis.

**Figure 5: Front (PLIM) Side Exterior Cosmetic Components**

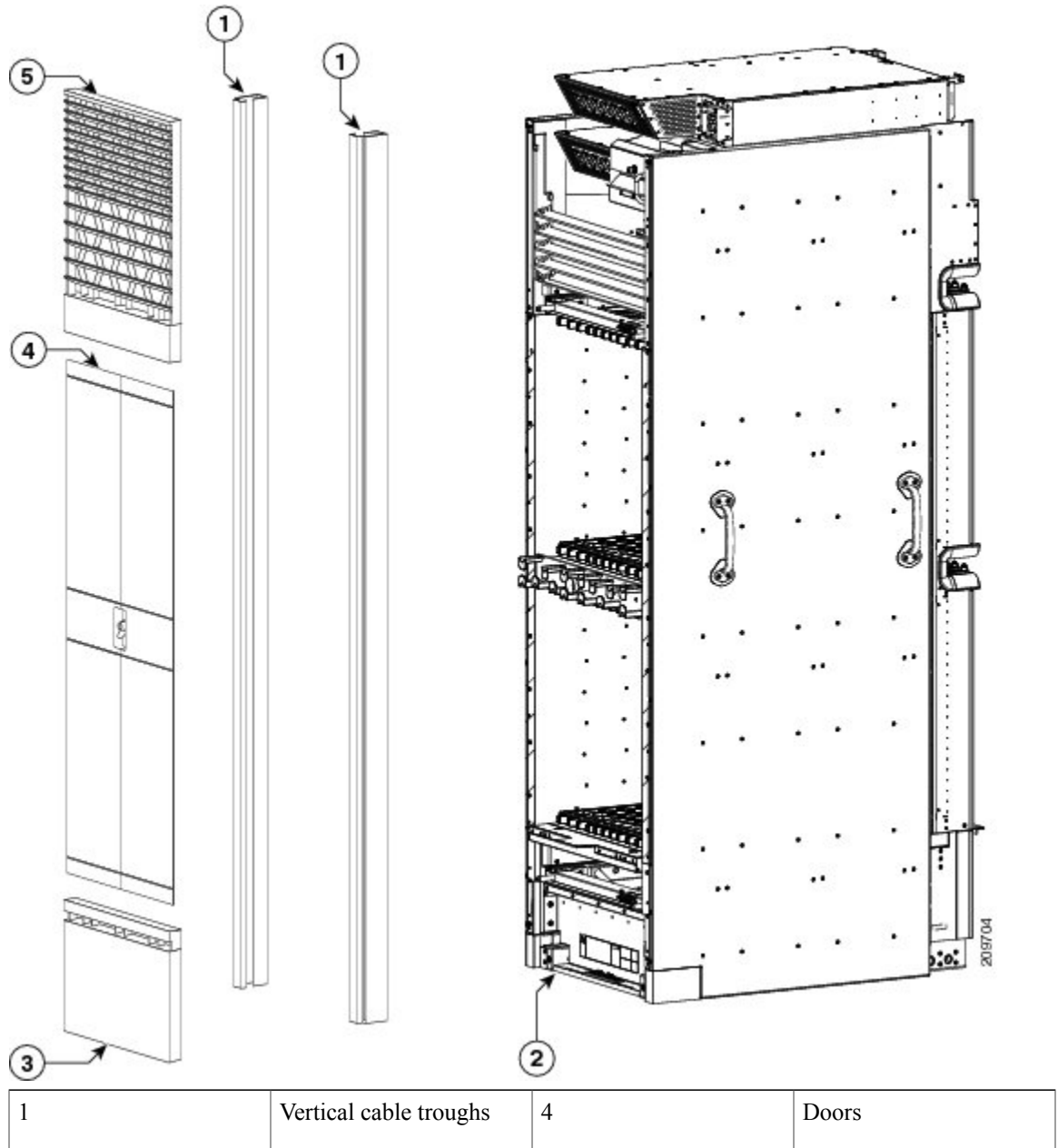


1	Upper grille support	5	Doors
2	Unistruts	6	Upper grille

3	Bracket for lower grille	7	Vertical cable troughs
4	Lower grille		

Figure 6: Rear (MSC) Side Exterior Cosmetic Components, on page 13 shows the exterior cosmetics on the rear (MSC) side of the LCC.

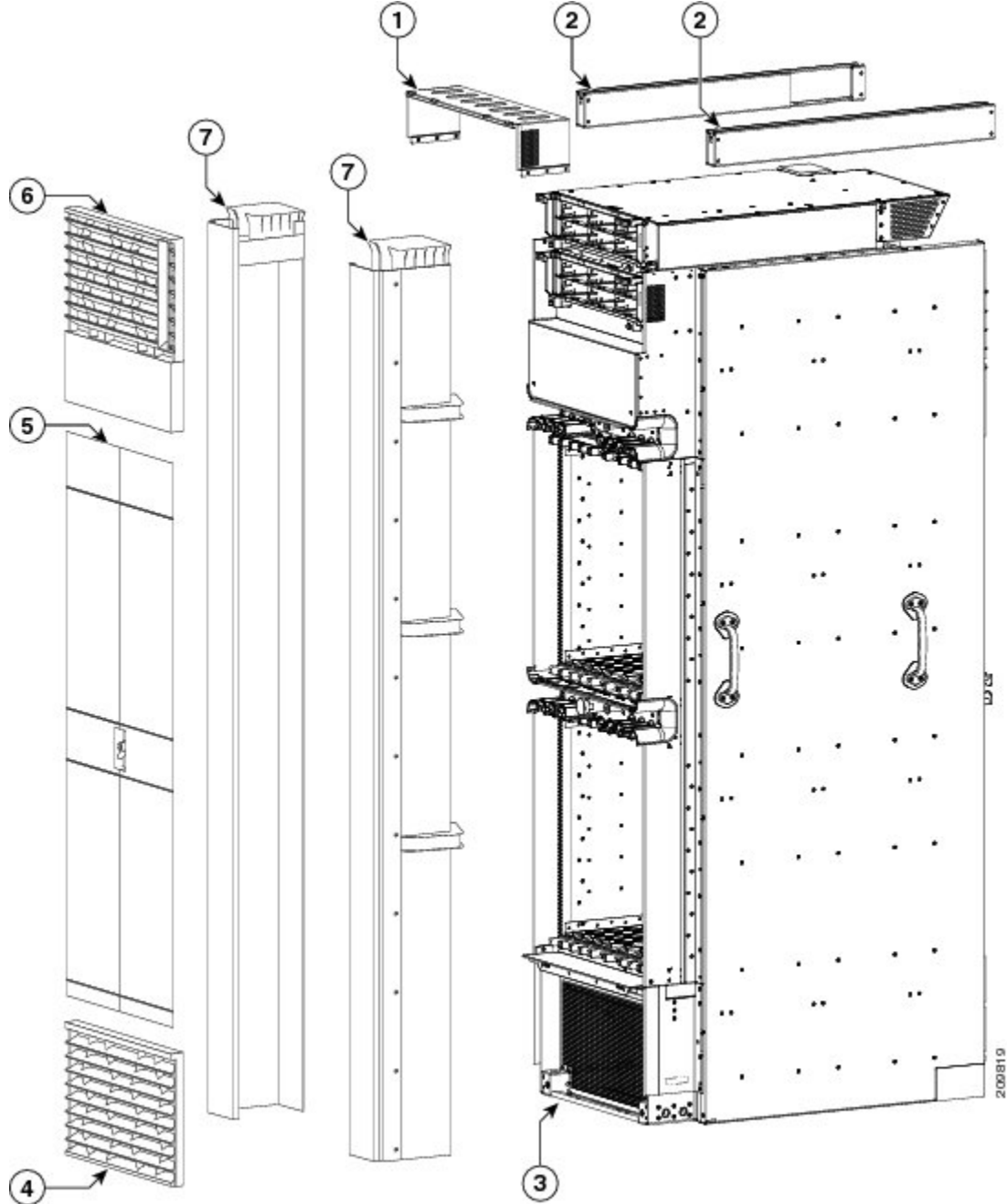
Figure 6: Rear (MSC) Side Exterior Cosmetic Components



2	Bracket for optional rear kick panel	5	Upper air grille
3	Rear kick panel (optional, orderable separately)		

Figure 7: Front (PLIM) Side Exterior Cosmetic Components—Optional Wide Duct System, on page 15 shows the exterior cosmetics for the front (PLIM) side of an optional wide duct system.

Figure 7: Front (PLIM) Side Exterior Cosmetic Components—Optional Wide Duct System



1	Upper grille support	5	Doors
2	Unistruts	6	Upper grille

3	Bracket for lower grille	7	Wide vertical cable troughs
4	Lower grille		

## Safety Guidelines

Before you perform any LCC installation procedures, review the safety guidelines in this section to avoid injuring yourself or damaging the equipment.



### Note

Although power shelves may be installed or removed without powering down the system, for safety purposes we recommend that you power down the system before you install or remove a power shelf.

The following guidelines are for your safety and to protect equipment. The guidelines do not include all hazards. Be alert.



### Note

Review the safety warnings listed in *Regulatory Compliance and Safety Information for the Cisco CRS Carrier Routing System* before installing, configuring, or troubleshooting any installed card.

- Never attempt to lift an object that might be too heavy for you to lift by yourself.
- Keep the work area clear and dust free during and after installation. Do not allow dirt or debris to enter into any laser-based components.
- Keep tools and router components away from walk areas.
- Do not wear loose clothing, jewelry, and other items that could get caught in the router while working with OIMs, SFCs, and their associated components.
- Use Cisco equipment in accordance with its specifications and product-usage instructions.
- Do not work alone if potentially hazardous conditions exist.
- Make sure your installation follows national and local electrical codes: in the United States, National Fire Protection Association (NFPA) 70, United States National Electrical Code; in Canada, Canadian Electrical Code, part I, CSA C22.1; in other countries, International Electrotechnical Commission (IEC) 60364, part 1 through part 7.
- Connect only a DC power source that follows the safety extra-low voltage (SELV) requirements in UL/CSA/IEC/EN 60950-1 and AS/NZS 60590 to the DC-input power system.
- Make sure that you have a readily accessible two-poled disconnect device incorporated in the fixed configuration wiring of a CRS configured with the DC-input power system.
- Make sure that you provide short-circuit (overcurrent) protection as part of the building installation.

## Preventing Electrostatic Discharge

Electrostatic discharge (ESD) damage, which can occur when electronic cards or components are improperly handled, results in complete or intermittent failures. We recommend use of an ESD-preventive strap whenever you handle network equipment or one of its components.

Following are guidelines for preventing ESD damage:

- Always use an ESD-preventive wrist or ankle strap, and ensure that it makes good skin contact. Connect the equipment end of the connection cord to an ESD connection socket on the router or to a bare metal surface on the chassis.
- Handle a card by its ejector levers, when applicable, or its metal carrier only; avoid touching the board or connector pins.
- Place a removed card board side up on an antistatic surface or in a static-shielding bag. If you plan to return the component to the factory, immediately place it in a static-shielding bag.
- Avoid contact between the card and clothing. The wrist strap protects the board from only ESD voltage on the body; ESD voltage on clothing can still cause damage.







## Installing Power Components

This chapter provides instructions on how to install Cisco CRS Enhanced 16-Slot Line Card Chassis power components.

This chapter presents the following topics:

- [Power Systems Overview](#), page 19
- [How to Install Power Components](#), page 27
- [Power Up and Power Down a Chassis](#), page 68

### Power Systems Overview

The chassis power system provides power to chassis components and is made up of two AC or DC power shelves that contain AC or DC power modules (PMs) and alarm modules.

The AC power system requires single-phase AC input power to the power shelves. If you have 3-phase AC Delta or AC Wye at your equipment, a *Cisco CRS power distribution unit (PDU)* will be required to convert 3-phase AC input power to single-phase AC input power for the power shelf. The power system also includes SNMP MIBS and XML support.

**Note**

In the AC power system, PDU refers to the *Cisco CRS PDU* which is required to convert 3-phase AC-Wye or AC-Delta input power to single-phase AC input power for the AC power shelf. For further information and installation instructions, refer to the [Cisco CRS 3-Phase AC Power Distribution Unit Installation Guide](#).

This section contains the following topics:

### Basic Chassis Power Details

The Cisco CRS Series Enhanced 16-slot Line Card Chassis can be configured with either an AC-input power system or a DC-input power system. Site power requirements differ, depending on the source voltage used. Follow these precautions and recommendations when planning power connections to the router:

- Check the power at your site before installation to ensure that you are receiving clean power. Install a power conditioner, if necessary.
- Install proper grounding to avoid damage from lightning and power surges.

The Cisco CRS Series Enhanced 16-slot Line Card Chassis requires that at least one power shelf and its components be installed to operate properly; however, if you install only one power shelf and its components, your system will not be 2N redundant.

Two types of power shelves exist: an AC shelf and a DC shelf. An AC power shelf houses the AC PMs, while a DC power shelf houses the DC PMs. It is required that you use only one type of power shelf, either AC or DC, in a chassis at a time.

**Danger**

---

The chassis might have more than one power connection. All connections must be removed to de-energize the chassis. Statement 1028

---

## Bonding and Grounding Guidelines

The router chassis has two safety earth ground connections. The chassis allows you to connect the central office ground system or interior equipment grounding system to the bonding and grounding receptacles on the router chassis. Threaded ground inserts are located on top of the chassis rear (MSC) side panel to the right of the lower power shelf. There are also two sets of grounding studs located at the bottom of the rear (MSC) side of the chassis.

[Figure 8: NEBS Bonding and Grounding Points—Top Rear \(MSC\) Side of Chassis, on page 21](#) shows the grounding points at the top on the rear (MSC) side of the chassis. This grounding point is also referred to as the network equipment building system (NEBS) bonding and grounding point.

**Note**

---

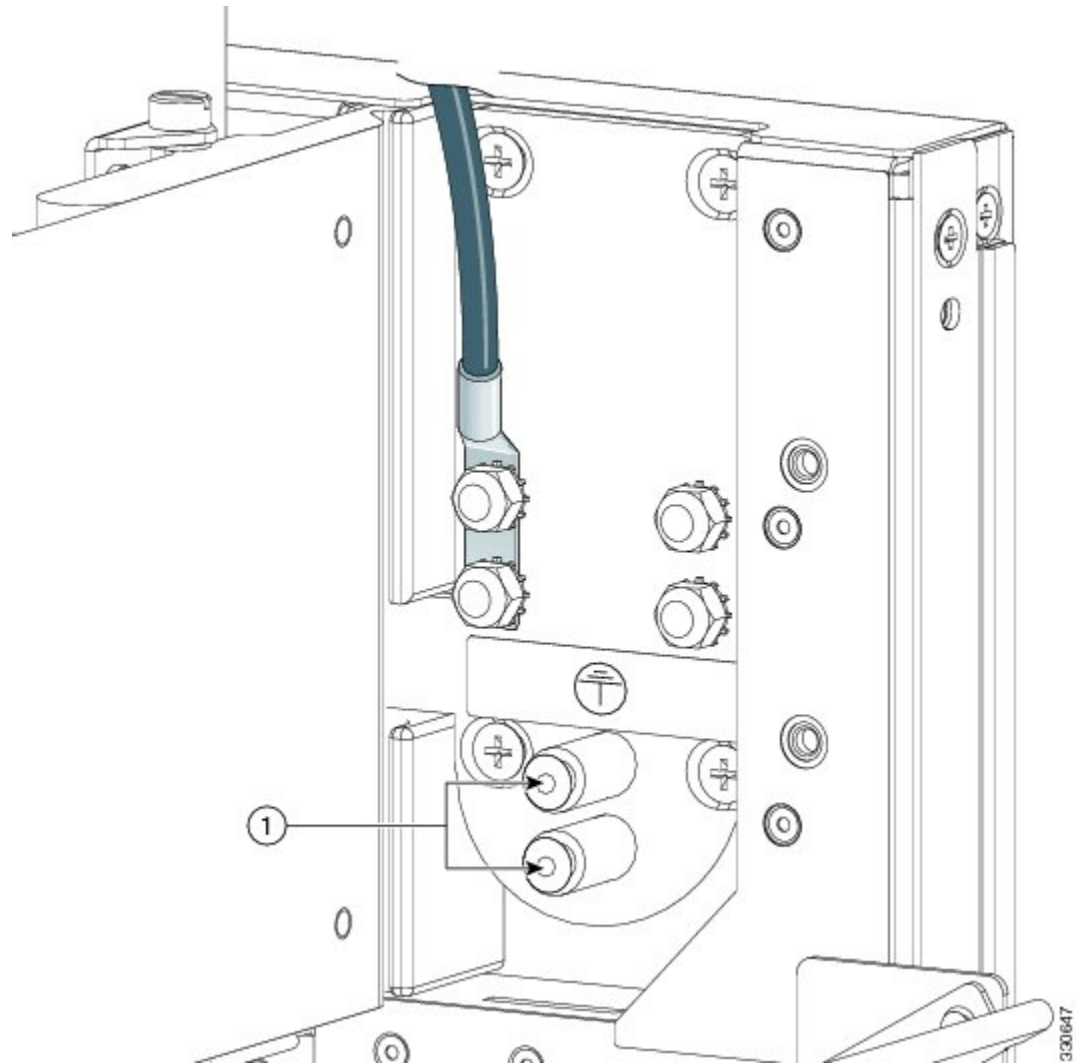
These bonding and grounding receptacles are provided to satisfy the Telcordia NEBS requirements for bonding and grounding connections.

---

**Caution**

Do not remove the chassis ground cable unless the chassis is being replaced.

**Figure 8: NEBS Bonding and Grounding Points—Top Rear (MSC) Side of Chassis**



1

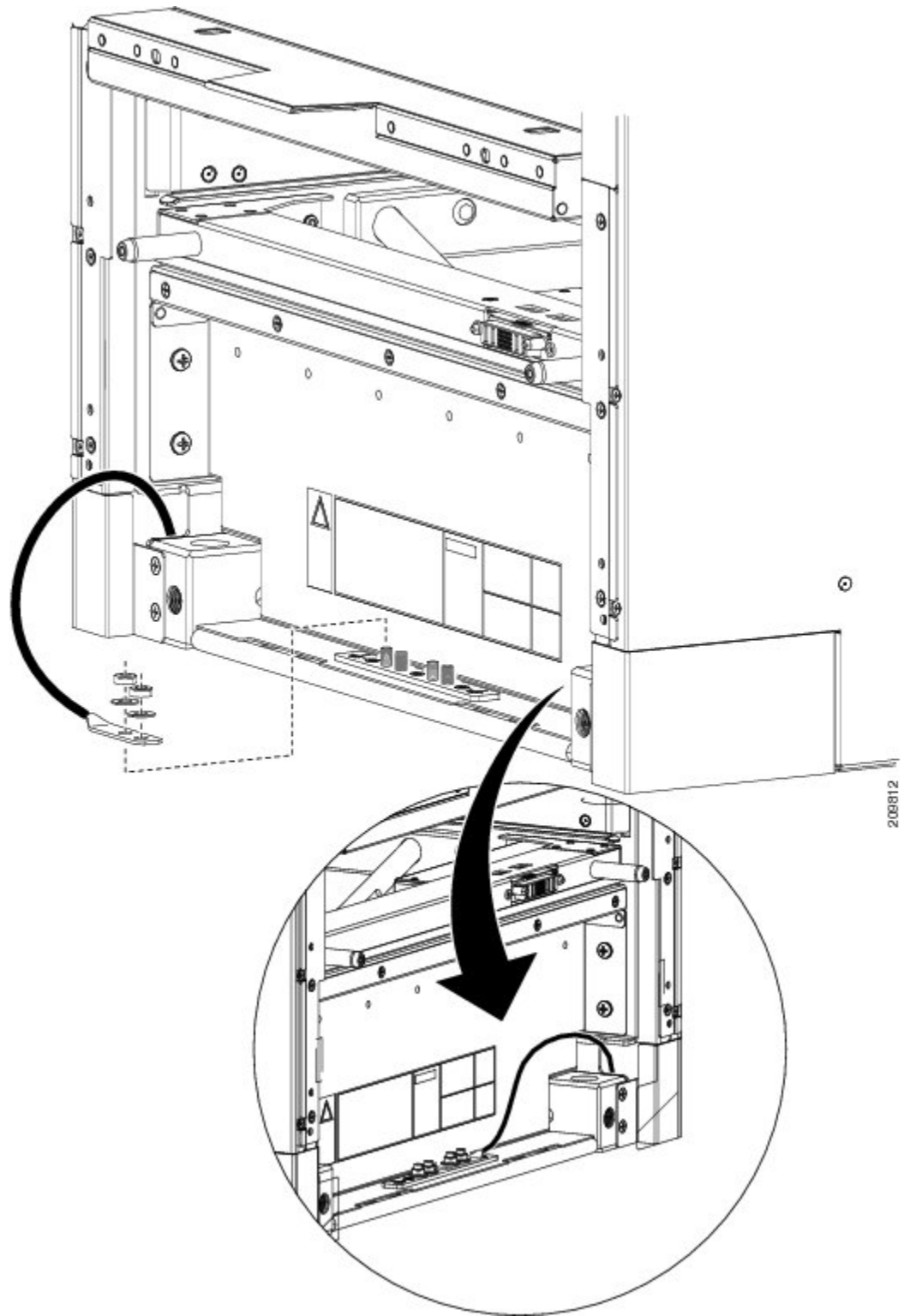
Two Torx security screws

**Note**

The two bolts below the NEBS bonding and grounding points at the top of the chassis are required for proper bonding and grounding of the chassis and should not be removed.

Figure 9: NEBS Bonding and Grounding Points—Bottom Rear (MSC) Side of Chassis, on page 22 shows the NEBS and grounding points at the bottom on the rear (MSC) side of the chassis.

*Figure 9: NEBS Bonding and Grounding Points—Bottom Rear (MSC) Side of Chassis*



## DC Power Systems

The Cisco CRS Series Enhanced 16-slot Line Card Chassis DC power system can provide up to 16,800 watts to power the chassis. However, by default, the power capability of a system when shipped, with six DC PMs per power shelf, is 12,600 watts.



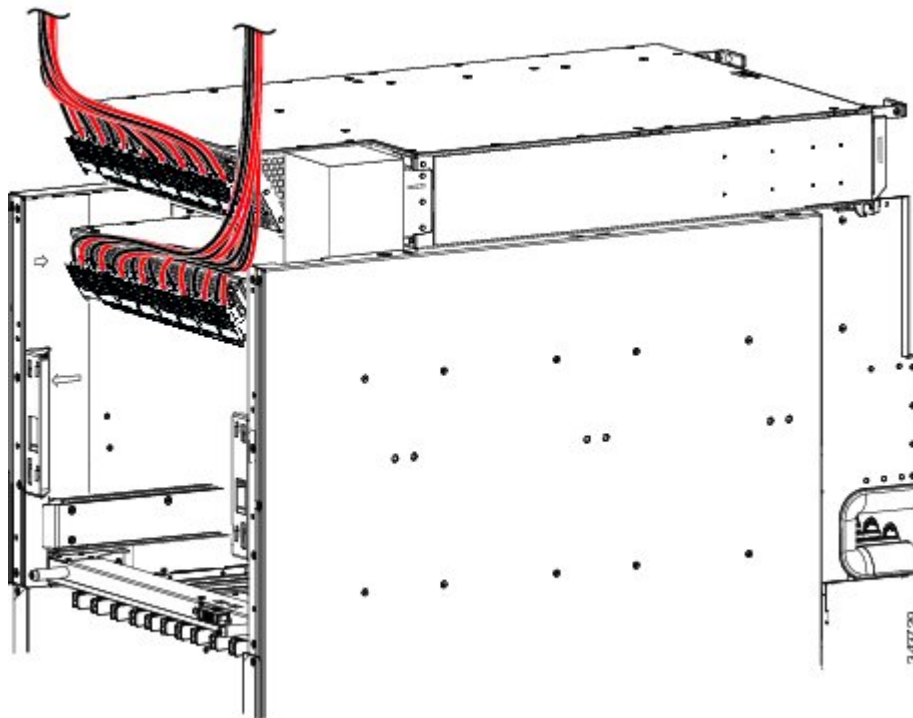
### Note

Depending on the hardware deployed at your site, your system may not consume the maximum power supplied by the power system.

Each DC powered chassis contains two DC power shelves for 2N redundancy. The shelves contain the input power connectors. Each shelf can accept up to eight DC PMs. The power shelves and DC PMs are field replaceable.

[Figure 10: DC Power Shelf Cable Wiring for Power Shelf](#), on page 24 shows the cable wiring for the power shelf.

**Figure 10: DC Power Shelf Cable Wiring for Power Shelf**



Each power shelf operates with up to eight DC inputs of  $-48/-60$  VDC (nominal), 60A. The power shelf accepts input DC power in the range  $-40$  to  $-72$  VDC.

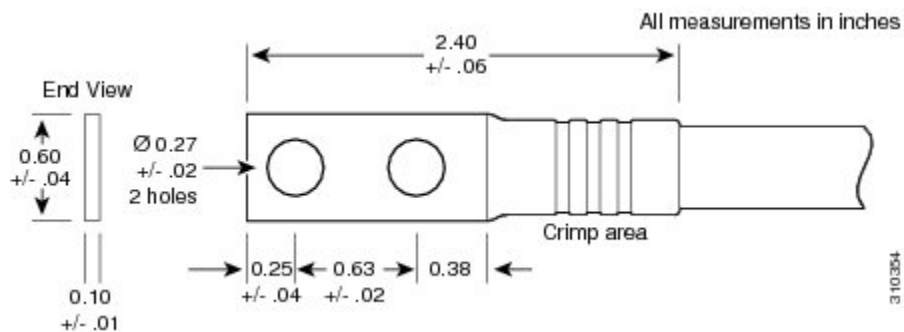
[Table 3: DC Input Current and Voltage Information](#), on page 25 lists the DC input current and voltage specifications.

**Table 3: DC Input Current and Voltage Information**

Nominal input voltage	-48 VDC North America-60 VDC European Community(range: -40 VDC to -72 VDC)
Input line current	50 A maximum at -48 VDC40 A maximum at -60 VDC60 A maximum at -40 VDC

Each wiring block on the DC power shelf contains two sets of terminals, one positive and one negative, and is covered by a plastic terminal block cover that is secured by a screw to a torque of 5 to 7 in.-lb (0.56 to 0.79 N-m). Each DC power cable is connected to the power shelf with a torque of 20 in.-lb (2.26 N-m). Maximum wire size at the DC input terminal block is 2 AWG.

The power supply terminal posts are centered 0.63 inches (5/8 inch) (1.60 cm) apart and are M6-threaded. We recommend that you use an appropriately sized 180-degree angle (straight) industry standard 2-hole, standard barrel compression lug, as shown in [Figure 11: DC Power Cable Lug](#), on page 25.

**Figure 11: DC Power Cable Lug**

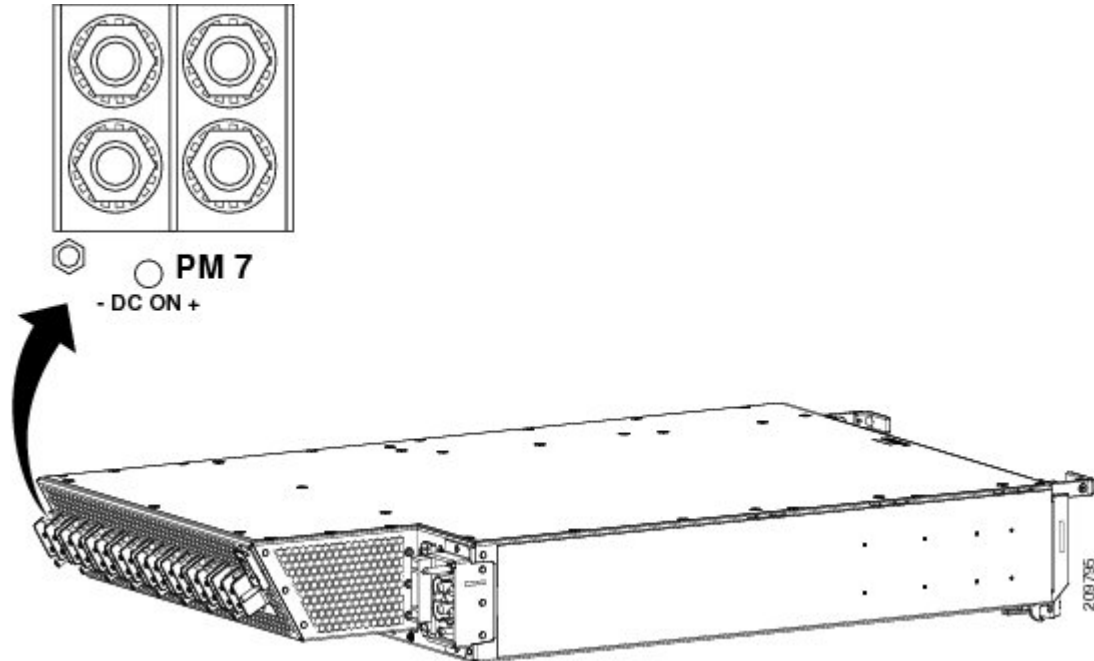
For additional power details, see [Appendix A, "Cisco CRS Series Carrier Routing System 16-Slot EC Line Card Chassis Specifications"](#) or the [Cisco CRS Series Carrier Routing System 16-Slot Line Card Chassis System Description](#).

## Input-Power-Present LEDs

The DC input-power-present LEDs provide a visual indication to service personnel that there is voltage present across the input terminal connection.

Figure 12: Input-Power-Present LEDs, on page 26 shows the input-power-present LEDs on the rear of the DC power shelf.

**Figure 12: Input-Power-Present LEDs**



**Note**

Power should be disconnected before servicing the input power connection.

The input-power-present LED starts to light up when the input voltage reaches  $-20$  VDC and the LED gets brighter as voltage increases; the input-power-present LED is fully lit when the input voltage reaches  $-38$  VDC.



**Caution**

If the input voltage polarity is reversed, or if the LED circuit fails, the LED will not light. When this is the case, service personnel should check for hazardous voltages before working on the unit.

## AC Power Systems

The Cisco CRS Series Enhanced 16-slot Line Card Chassis AC power system can provide up to 18,000 watts to power the chassis. However, by default, the power capability of a system when shipped, with five AC PMs per power shelf, is 15,000 watts.



**Note**

Depending on the hardware deployed at your site, your system may not consume the maximum power supplied by the power system.



Each AC powered chassis contains two AC power shelves for 2N redundancy. The shelves contain the input power connectors. Each shelf can contain up to six AC PMs. The power shelves and the AC PMs are field replaceable.

The AC power system requires single-phase AC input power. If you have 3-phase AC Delta or AC Wye at your equipment, a *Cisco CRS PDU* will be required to convert 3-phase AC input power to single-phase AC input power for the power shelf. For further information and installation instructions, refer to the [Cisco CRS 3-Phase AC Power Distribution Unit Installation Guide](#).

The AC power shelf has the following input VAC power requirements:

- Single-phase, 200 to 240 VAC nominal, 50 to 60 Hz, 16 A.
- Each power shelf contains six IEC-320-C22 receptacles which can accept up to six IEC-320-C21 connector plugs.

**Note**

If you have a Cisco CRS 3-Phase AC PDU installed, six AC PMs are required to be installed in each Cisco CRS Series Enhanced 16-slot Line Card Chassis AC power shelf to maintain a balanced 3-phase power load.

**Note**

We recommend that you use appropriate short-circuit protection in compliance with national and local electrical codes.

For additional power details, see [Appendix A, “Cisco CRS Series Carrier Routing System 16-Slot EC Line Card Chassis Specifications”](#) or the Cisco CRS Series Carrier Routing System *16-Slot Line Card Chassis System Description*.

## How to Install Power Components

This section describes how to install power components in the Cisco CRS Series Enhanced 16-slot Line Card Chassis.

**Note**

Although there are differences between the different types of power shelves and PMs (AC and DC), they are installed using the same procedures.

We recommend that you install the power components in the order outlined in this section. This section contains the following procedures:

### Installing the Power A Bus Bar

This section describes how to install the Power A bus bar on the rear (MSC) side of the Cisco CRS Series Enhanced 16-slot Line Card Chassis. For complete information on regulatory compliance and safety, see *Regulatory Compliance and Safety Information for the Cisco CRS Carrier Routing System*.

## Prerequisites

There are no prerequisites for this task.

## Required Tools and Equipment

You need the following tool to perform this task:

- 6-in. long number 1 Phillips screwdriver

## Steps

To install the Power A bus bar on the chassis, perform the following steps:

### SUMMARY STEPS

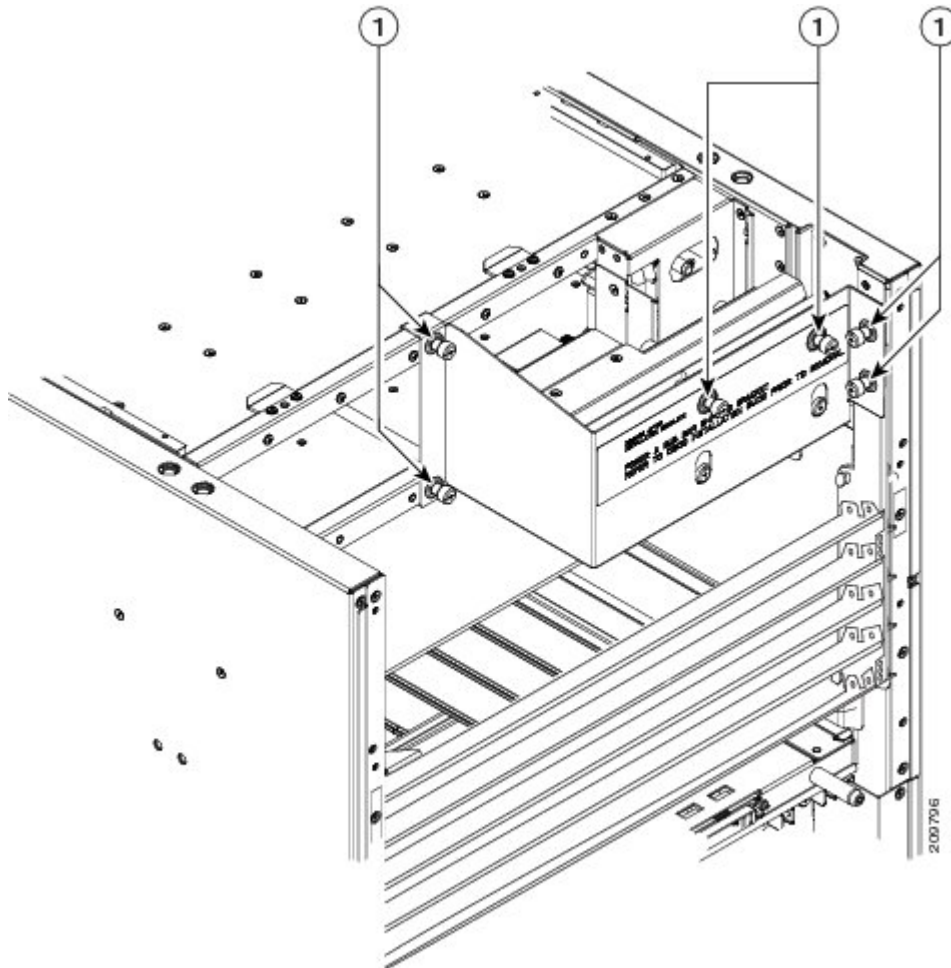
1. To release the Power A bus bar from the shipping position, loosen the six captive screws that attach the bus bar shipping bracket to the rear of the chassis. There are two screws on the right side, two screws on the front, and two screws on the left side of the Power A bus bar shipping bracket. See [Figure 13: Removing the Power A Bus Bar Shipping Bracket, on page 29](#).
2. Remove the Power A bus bar shipping bracket from the chassis and set it aside.
3. Remove the Power A bus bar from the rear of the chassis. See [Figure 14: Removing the Cover From the Power A Bus Bar, on page 30](#).
4. Remove the cover from the Power A bus bar by loosening the two captive screws that attach the cover to the bus bar. See [Figure 14: Removing the Cover From the Power A Bus Bar, on page 30](#).
5. Position the power block vertically. Mate the power block pivot and chassis pivot point together. See item 2 in [Figure 15: Power A Bus Bar Installed in Chassis, on page 32](#).
6. Unscrew the two handle screws on the power bus bar and open the handle. See item 3 on [Figure 15: Power A Bus Bar Installed in Chassis, on page 32](#).
7. Hold the power block cable to the side to keep clear of the power block connectors while seating the power block.
8. Seat the power block and tighten the two screws on the handle. See item 3 in [Figure 15: Power A Bus Bar Installed in Chassis, on page 32](#).
9. Tighten the Phillips captive screw that secures the tab on the left side of the power block to the chassis. See item 1 in [Figure 15: Power A Bus Bar Installed in Chassis, on page 32](#).

### DETAILED STEPS

- 
- Step 1** To release the Power A bus bar from the shipping position, loosen the six captive screws that attach the bus bar shipping bracket to the rear of the chassis. There are two screws on the right side, two screws on the front, and two screws on the left side of the Power A bus bar shipping bracket. See [Figure 13: Removing the Power A Bus Bar Shipping Bracket, on page 29](#).

**Note** The Power A bus bar is pre-attached to the top rear of the chassis in a horizontal position using a bus bar shipping bracket, due to shipping height restrictions.

**Figure 13: Removing the Power A Bus Bar Shipping Bracket**



1	Captive screws securing Power A bus bar bracket to rear of chassis
---	--

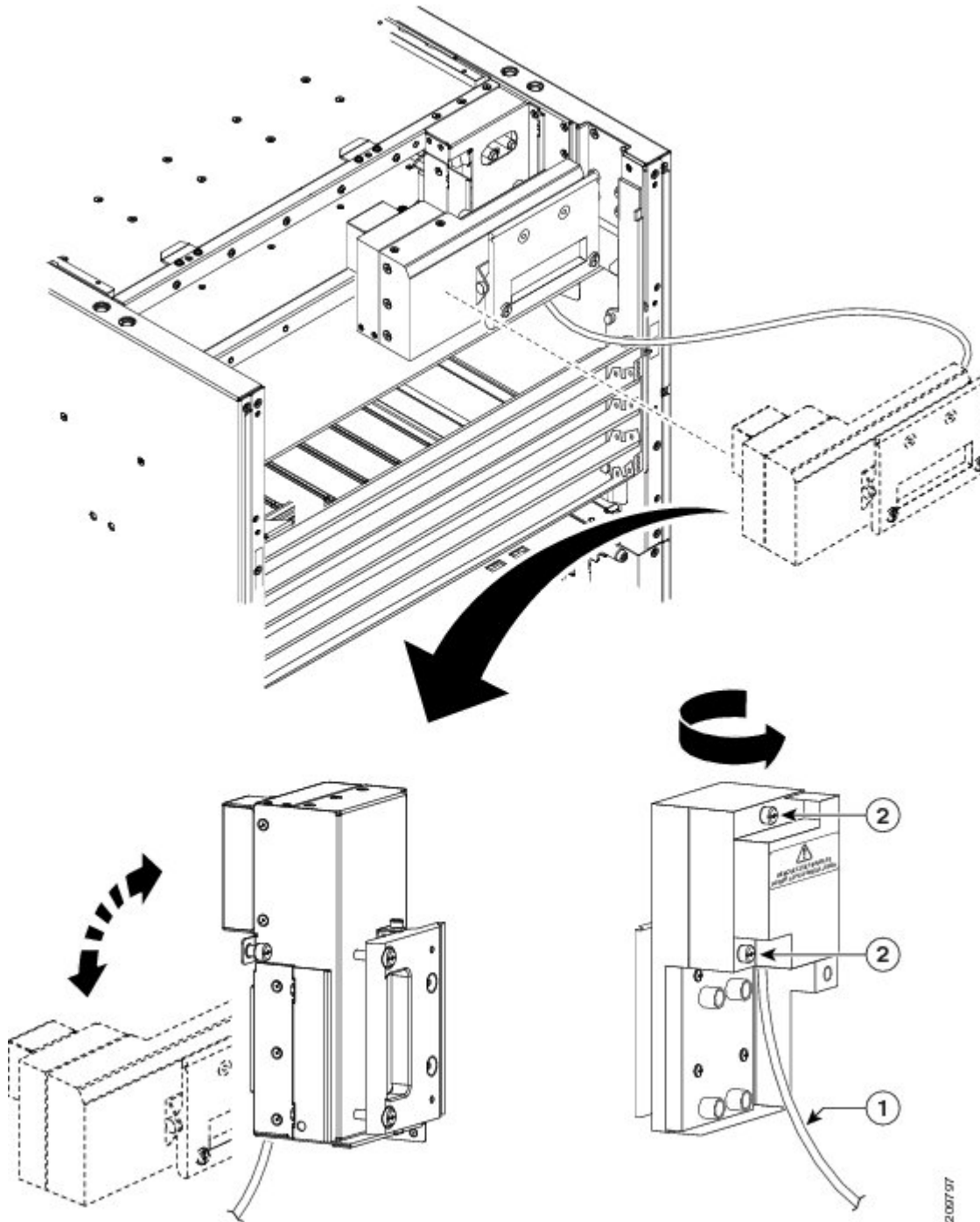
**Step 2** Remove the Power A bus bar shipping bracket from the chassis and set it aside.

**Step 3** Remove the Power A bus bar from the rear of the chassis. See [Figure 14: Removing the Cover From the Power A Bus Bar](#), on page 30.

**Note** The Power A bus bar is connected to the chassis with an internal cable. Be careful not to drop the power bus bar.

- Step 4** Remove the cover from the Power A bus bar by loosening the two captive screws that attach the cover to the bus bar. See [Figure 14: Removing the Cover From the Power A Bus Bar](#), on page 30.

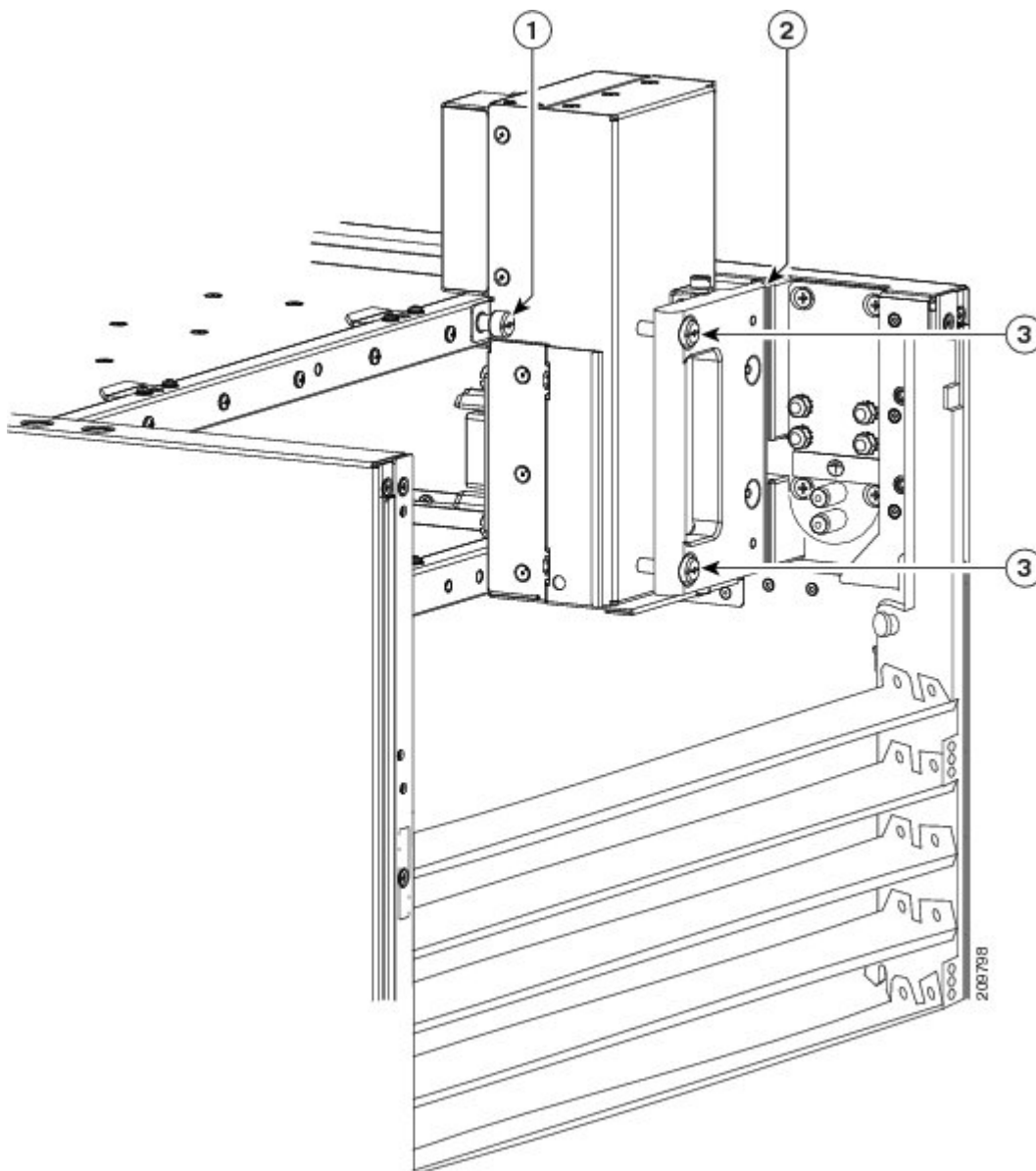
**Figure 14: Removing the Cover From the Power A Bus Bar**



1	Internal cable connection
2	Screws attaching cover to Power A bus bar

- Step 5** Position the power block vertically. Mate the power block pivot and chassis pivot point together. See item 2 in [Figure 15: Power A Bus Bar Installed in Chassis](#), on page 32.
- Step 6** Unscrew the two handle screws on the power bus bar and open the handle. See item 3 on [Figure 15: Power A Bus Bar Installed in Chassis](#), on page 32.
- Step 7** Hold the power block cable to the side to keep clear of the power block connectors while seating the power block.
- Step 8** Seat the power block and tighten the two screws on the handle. See item 3 in [Figure 15: Power A Bus Bar Installed in Chassis](#), on page 32.

**Figure 15: Power A Bus Bar Installed in Chassis**



1

Captive screw securing Power A bus bar to chassis

2	Chassis pivot point
3	Two screws securing handle to Power A bus bar

**Step 9** Tighten the Phillips captive screw that secures the tab on the left side of the power block to the chassis. See item 1 in [Figure 15: Power A Bus Bar Installed in Chassis](#), on page 32.

## What to Do Next

After the Power A bus bar has been installed, install the upper grille support. Continue to the [Installing the Upper Grille Support](#), on page 33 for more information.

## Installing the Upper Grille Support

This section describes how to install the upper grille support on the Cisco CRS Series Enhanced 16-slot Line Card Chassis. For complete information on regulatory compliance and safety, see *Regulatory Compliance and Safety Information for the Cisco CRS Carrier Routing System*.

Although the upper grille support is an exterior cosmetic component, it must be installed prior to installing the upper chassis ground cable and the power shelves.

### Prerequisites

Before performing this task, perform the following procedure:

### Required Tools and Equipment

You need the following tools and equipment to perform this task:

- 6-in. long number 1 Phillips screwdriver
- Upper grille support

### Steps

To attach the upper grille support to the chassis, perform the following steps:

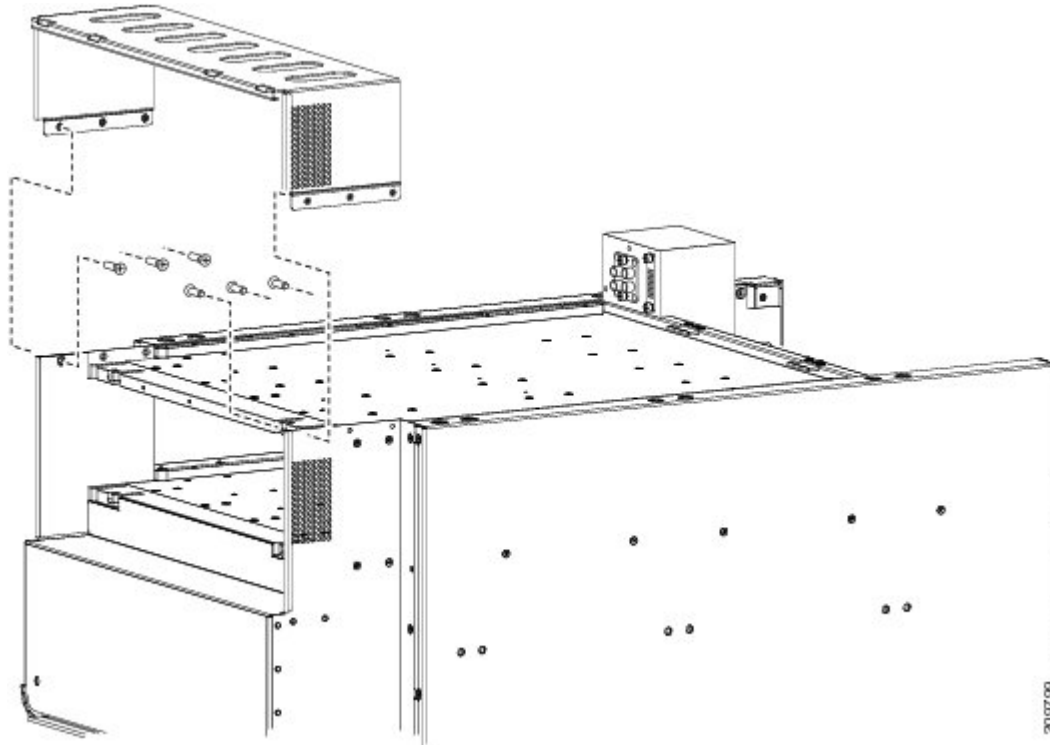
#### SUMMARY STEPS

1. Attach the upper grille support to the front of the chassis. Use the screwdriver to install the six M4 flat head screws, three on each side, to the chassis. See [Figure 16: Attaching the Upper Grille Support to the Chassis](#), on page 34.

## DETAILED STEPS

Attach the upper grille support to the front of the chassis. Use the screwdriver to install the six M4 flat head screws, three on each side, to the chassis. See [Figure 16: Attaching the Upper Grille Support to the Chassis](#), on page 34.

**Figure 16: Attaching the Upper Grille Support to the Chassis**



## What to Do Next

After the upper grille support has been installed, attach the unistruts. Continue to the [Installing the Unistruts](#), on page 34 for more information.

## Installing the Unistruts

This section describes how to install the unistruts on the Cisco CRS Series Enhanced 16-slot Line Card Chassis. For complete information on regulatory compliance and safety, see *Regulatory Compliance and Safety Information for the Cisco CRS Carrier Routing System*.

Although the unistruts are exterior cosmetic components, they should be installed prior to installing the upper chassis ground cable and the power shelves.



## Prerequisites

Before performing this task, perform the following procedures:

## Required Tools and Equipment

You need the following tools and equipment to perform this task:

- 8mm hex bit socket
- 3/8-in. drive ratchet wrench
- Torque wrench with 13-mm hex key and rated accuracy at 40 to 50 in.-lb (4.52 to 5.65 N-m)
- Unistruts

## Steps

To attach the unistruts to the chassis, perform the following steps:

### SUMMARY STEPS

1. Attach each unistrut to the top of the chassis by inserting four M12 hex head bolts and washers, two for each strut, into the bolt holes on the inside of the strut, and tightening with the 8mm hex bit socket and ratchet wrench. The closed end of a unistrut faces the front (PLIM) side of the chassis. See [Figure 17: Attaching the Unistrut, on page 36](#).

### DETAILED STEPS

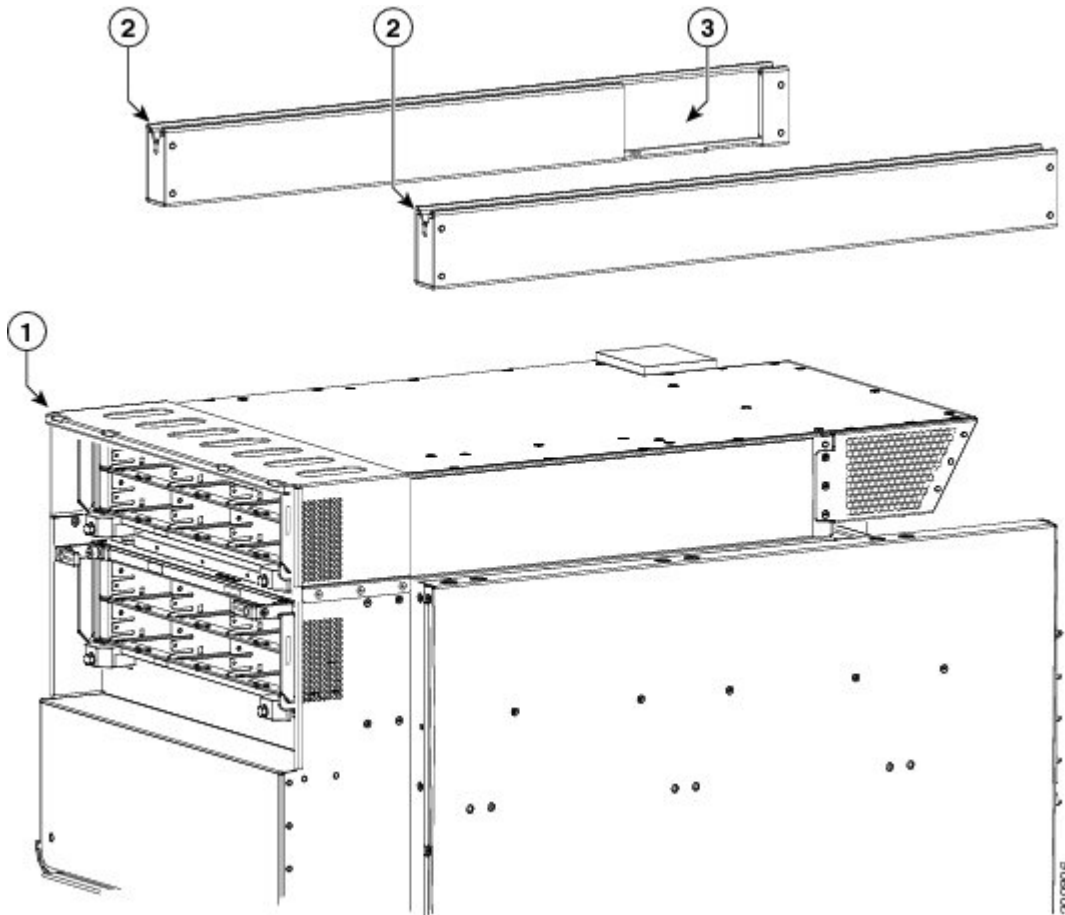
---

Attach each unistrut to the top of the chassis by inserting four M12 hex head bolts and washers, two for each strut, into the bolt holes on the inside of the strut, and tightening with the 8mm hex bit socket and ratchet wrench. The closed end of a unistrut faces the front (PLIM) side of the chassis. See [Figure 17: Attaching the Unistrut, on page 36](#).

**Note** The left unistrut (as you face the front [PLIM] side of the chassis) has a cutaway in the rear to admit the chassis ground cable; the right unistrut does not. The right unistrut as viewed from the front PLIM side of the router has a bolt position that is 6.5 inches from the end at the rear of the router.

**Caution** Cisco recommends an install torque range for the unistrut bolts between 40 and 50 in.-lb (between 4.52 N-m and 5.65 N-m).

**Figure 17: Attaching the Unistrut**



1	Upper grille support	3	Cutaway for ground cable
2	Unistruts		

## What to Do Next

After the upper grille support has been installed, install the chassis ground cable. Continue to the [Installing the Chassis Ground Cable](#), on page 37 for more information.

## Installing the Chassis Ground Cable

This section describes how to install the chassis ground cable on the Cisco CRS Series Enhanced 16-slot Line Card Chassis. For complete information on regulatory compliance and safety, see *Regulatory Compliance and Safety Information for the Cisco CRS Carrier Routing System*.

### Prerequisites

Before performing this task, perform the following procedures:

### Required Tools and Equipment

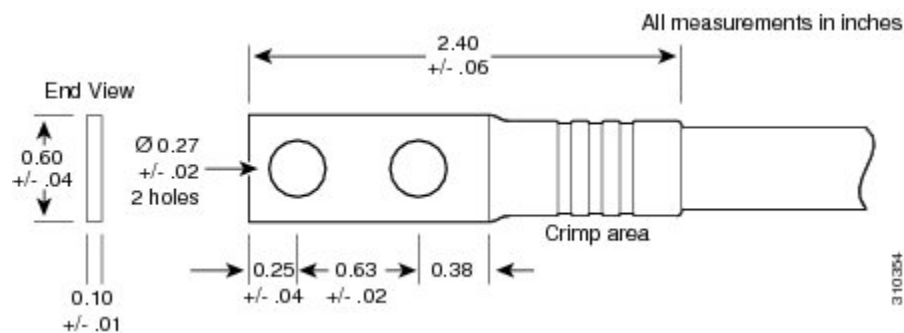
You need the following tools and equipment to perform this task:

- Ground lug
- Ground cable
- Crimping tool and lug specific die
- 3/8 in. drive socket wrench
- 10-mm 6 pt. socket
- Torque wrench with 10-mm 6 pt. socket and rated accuracy at 30 in.-lb (3.39 N-m)

To ensure a satisfactory ground connection, you also need the following parts:

- One 180-degree angle (straight) grounding lug that has two M6 bolt holes with 0.63 inches (5/8 inch) (1.60 cm) of spacing center to center between them and a 6 AWG or larger multistrand copper wire. See [Figure 18: 180-Degree \(Straight\) Chassis Ground Lug](#), on page 37.

**Figure 18: 180-Degree (Straight) Chassis Ground Lug**



- Two M6 hex head bolts and integrated locking washers are pre-installed on the chassis.
- Cisco recommend at least 6 AWG multistrand copper ground cable. This cable is not available from Cisco Systems; it is available from any commercial cable vendor. The cable should be sized according to local and national installation requirements.

**Note**

---

The DC return of this system should remain isolated from the system frame and chassis (DC-I: Isolated DC Return).

---

## Steps

To attach the ground cable to the chassis, perform the following steps:

### SUMMARY STEPS

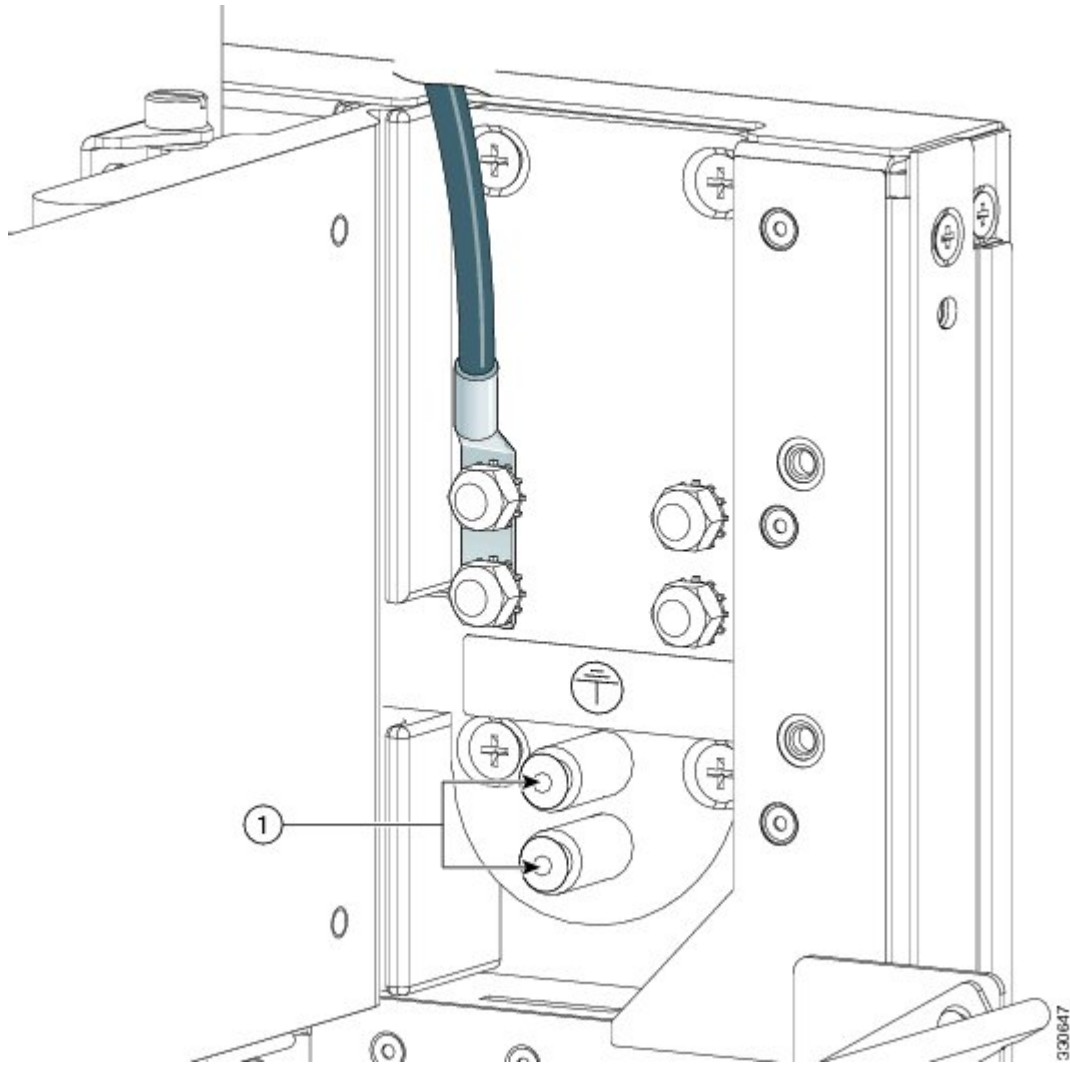
1. Use the crimping tool mandated by the lug manufacturer to crimp the lug to the ground cable.
2. Using the 10-mm wrench, attach the ground cable to the upper grounding point as shown in [Figure 19: NEBS Bonding and Grounding Points—Top of Chassis](#), on page 39 for overhead grounding. Use the optional lower grounding point, as shown in [Figure 20: NEBS Bonding and Grounding Points—Bottom of Chassis](#), on page 40 if the ground cable is run from under a raised floor.
3. Use the torque wrench to tighten to a torque of 30 in.-lb (3.39 N-m).
4. Connect the other end of the ground cable to a grounding point at your site, according to site requirements.

### DETAILED STEPS

- 
- Step 1** Use the crimping tool mandated by the lug manufacturer to crimp the lug to the ground cable.
- Step 2** Using the 10-mm wrench, attach the ground cable to the upper grounding point as shown in [Figure 19: NEBS Bonding and Grounding Points—Top of Chassis](#), on page 39 for overhead grounding. Use the optional lower grounding point,

as shown in [Figure 20: NEBS Bonding and Grounding Points—Bottom of Chassis](#), on page 40 if the ground cable is run from under a raised floor.

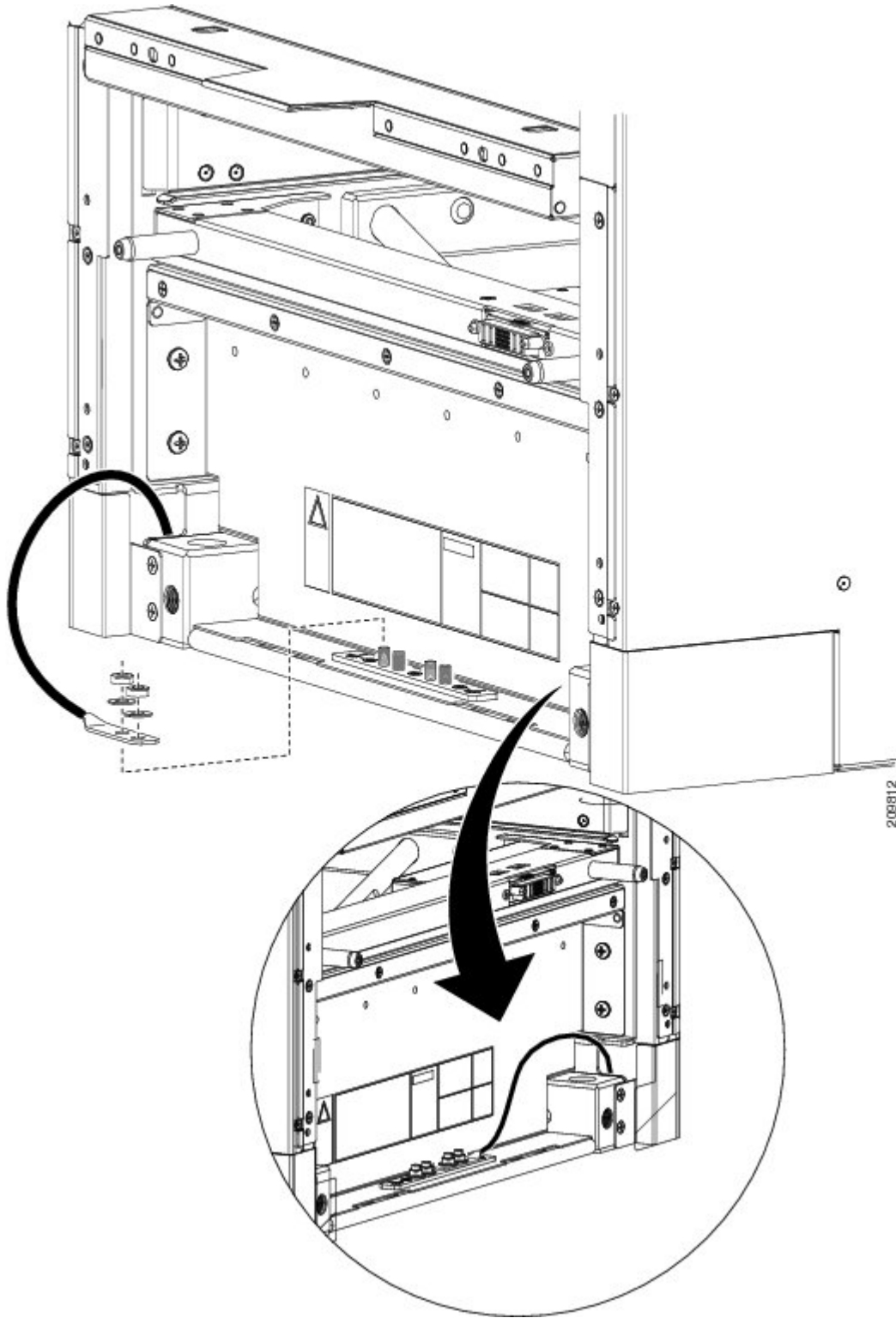
**Figure 19: NEBS Bonding and Grounding Points—Top of Chassis**



1	Two Torx security screws
---	--------------------------

**Note** The two bolts below the NEBS bonding and grounding points at the top of the chassis are required for proper bonding and grounding of the chassis and should not be removed.

**Figure 20: NEBS Bonding and Grounding Points—Bottom of Chassis**



- Step 3** Use the torque wrench to tighten to a torque of 30 in.-lb (3.39 N-m).
- Step 4** Connect the other end of the ground cable to a grounding point at your site, according to site requirements.

## What to Do Next

After the chassis ground cable has been attached, remove the exhaust air deflector from the rear of the chassis. Continue to the [“Removing the Exhaust Air Deflector”](#) section on page 7-45 for instructions.

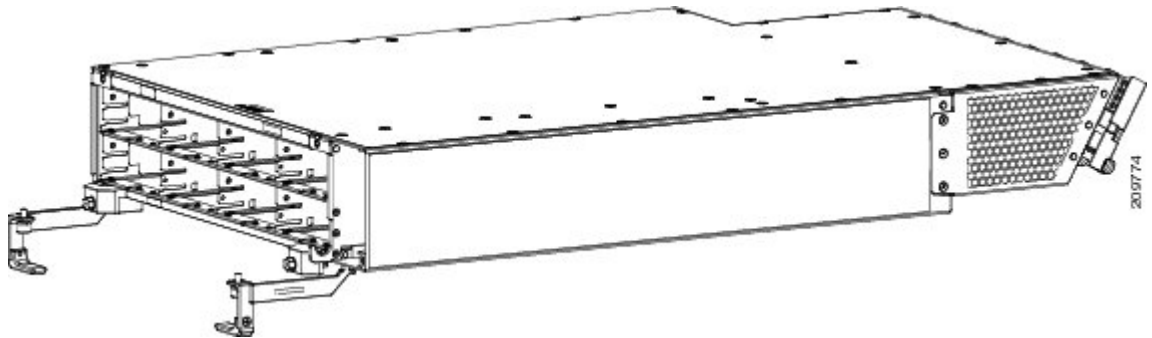
## Installing an AC or DC Power Shelf

This section describes how to install the AC or DC power shelves in the Cisco CRS Series Enhanced 16-slot Line Card Chassis. For complete information on regulatory compliance and safety, see *Regulatory Compliance and Safety Information for the Cisco CRS Carrier Routing System*.

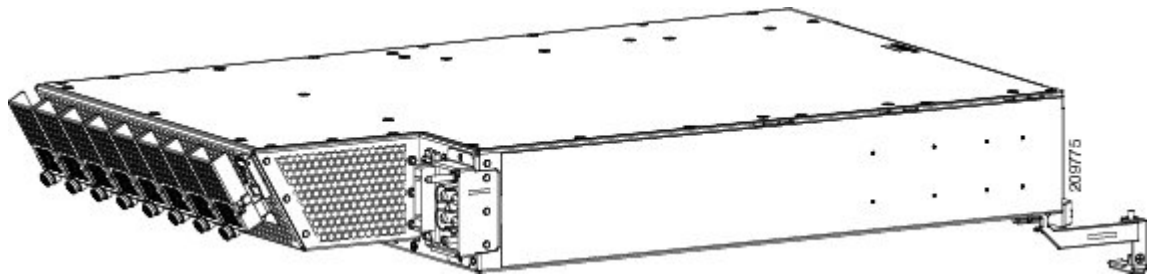
Although there are differences between the AC and DC power shelves, they are installed using the same procedures.

The front and rear views of the DC power shelves are shown in [Figure 21: DC Power Shelf—Front View](#), on page 42 and [Figure 22: DC Power Shelf—Rear View](#), on page 42.

**Figure 21: DC Power Shelf—Front View**



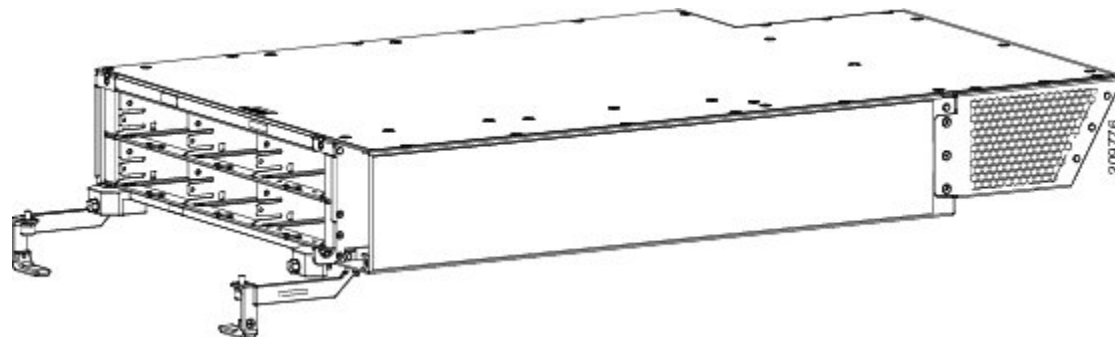
**Figure 22: DC Power Shelf—Rear View**



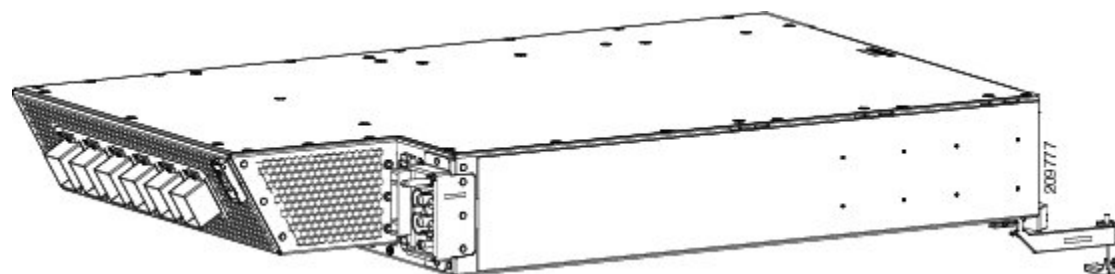


The front and rear views of the AC power shelf are shown in [Figure 23: AC Power Shelf—Front View](#), on page 43 and [Figure 24: AC Power Shelf—Rear View](#), on page 43.

**Figure 23: AC Power Shelf—Front View**



**Figure 24: AC Power Shelf—Rear View**



## Prerequisites

Before performing this task, perform the following procedures:

- [Installing the Power A Bus Bar](#), on page 27
- [Installing the Upper Grille Support](#), on page 33
- [Installing the Unistruts](#), on page 34
- [Installing the Chassis Ground Cable](#), on page 37
- [Removing the Exhaust Air Deflector](#), page 7-45 (if the lower power shelf is being installed)
- [Removing the Upper Rear Air Grille](#), page 7-21 (if installed)
- [Removing the Front Upper Grille](#), page 7-28 (if installed)
- [Removing the Upper Grille Support](#), page 7-52 (if installed)
- Verify that the power shelf that you are about to install is the correct power shelf, either AC or DC.



### Note

Do not install the power shelf in the chassis with AC or DC PMs, or alarm module installed in the power shelf.

## Required Tools and Equipment

You need the following tools to perform this task:

- 6-in. long number 2 Phillips screwdriver
- Torque screwdriver with number 2 Phillips head and rated accuracy at 15 in.-lb (1.69 N m) to 20 in.-lb (2.26 N m)
- AC or DC power shelf
  - AC power shelf (Cisco product number CRS-16-PWRSH-AC=), or
  - DC power shelf (Cisco product number CRS-16-PWRSH-DC=)

## Steps

To install the AC or DC power shelf, perform the following steps

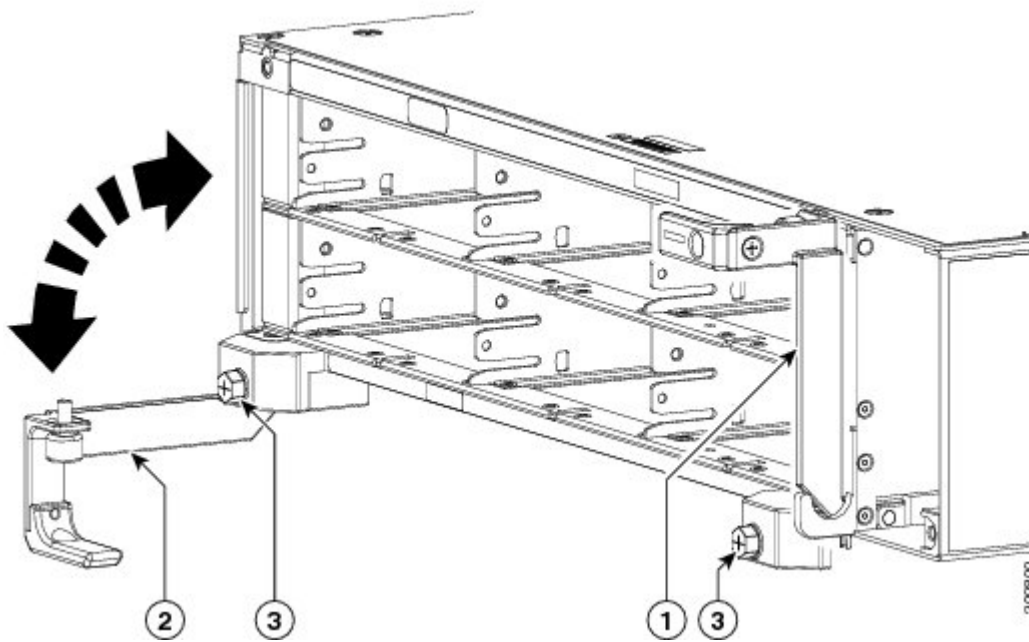
### SUMMARY STEPS

1. Unpack the shelves to be installed.
2. Using two people, one to support the power shelf underneath and the other to keep it steady, lift the power shelf up and slide it partway into the power shelf slot on the front (PLIM) side of the chassis. See [Figure 26: Installing the Power Shelf in the Chassis, on page 46](#).
3. Unscrew the ejector handles from the front face of the shelf, one on each side. See [Figure 25: Power Shelf Ejector Handles on Front of Power Shelf, on page 45](#).
4. Grasping both handles simultaneously, push both the left and right handles up and in at the same time to push the shelf into the chassis. Slide the shelf all the way into the chassis, until both power shelf handles hook around the pins.
5. Using the screwdriver, tighten the captive screw on both power shelves. See [Figure 27: Installing and Securing Power Shelf, on page 47](#) Figure 3-20 .
6. Using the torque screwdriver, tighten the two screws that attach the bottom of the power shelf, one on each side, to the chassis to a torque value of 15 in.-lb (1.69 N m) to 20 in.-lb (2.26 N m). See [Figure 27: Installing and Securing Power Shelf, on page 47](#).
7. Install the second power shelf, following through Step 3 through Step 6.

**DETAILED STEPS**

- Step 1** Unpack the shelves to be installed.
- Step 2** Using two people, one to support the power shelf underneath and the other to keep it steady, lift the power shelf up and slide it partway into the power shelf slot on the front (PLIM) side of the chassis. See [Figure 26: Installing the Power Shelf in the Chassis](#), on page 46.
- Step 3** Unscrew the ejector handles from the front face of the shelf, one on each side. See [Figure 25: Power Shelf Ejector Handles on Front of Power Shelf](#), on page 45.

**Figure 25: Power Shelf Ejector Handles on Front of Power Shelf**

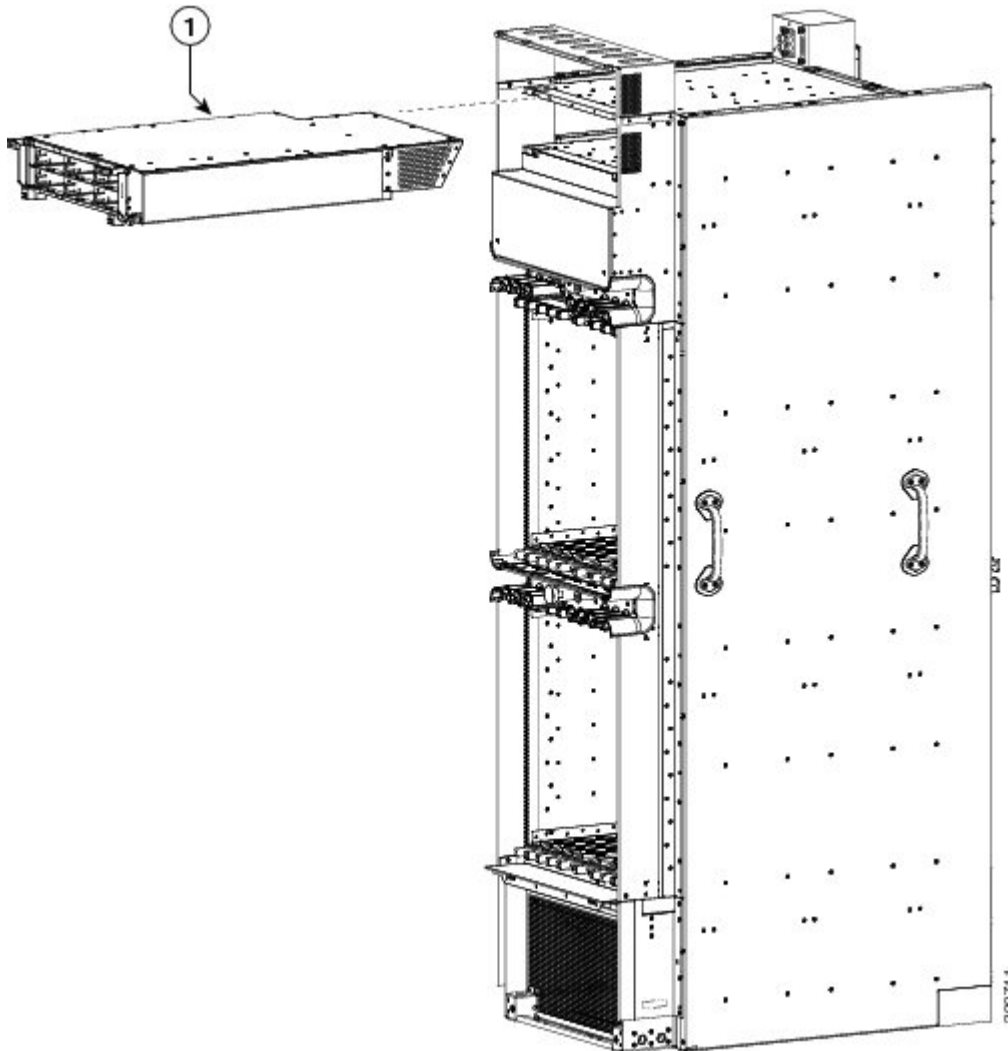


1	Power shelf ejector handle pushed up to slide shelf into chassis
2	Power shelf ejector handle pulled away from shelf
3	Screws that attach power shelf to chassis

**Caution** Because of the weight of the power shelf, 40 lbs (18 kg), and the height that the power shelf is installed in the chassis, you should be especially careful while lifting and installing the power shelf. To prevent injury, keep your back straight and lift with your legs, not your back. Avoid sudden twists or lateral moves.

**Note** Although you can install the power shelves in any order that you prefer, Cisco suggests that you install the upper power shelf first and then install the lower power shelf. Ensure that the first power shelf is properly seated before attempting to install the second power shelf.

**Figure 26: Installing the Power Shelf in the Chassis**



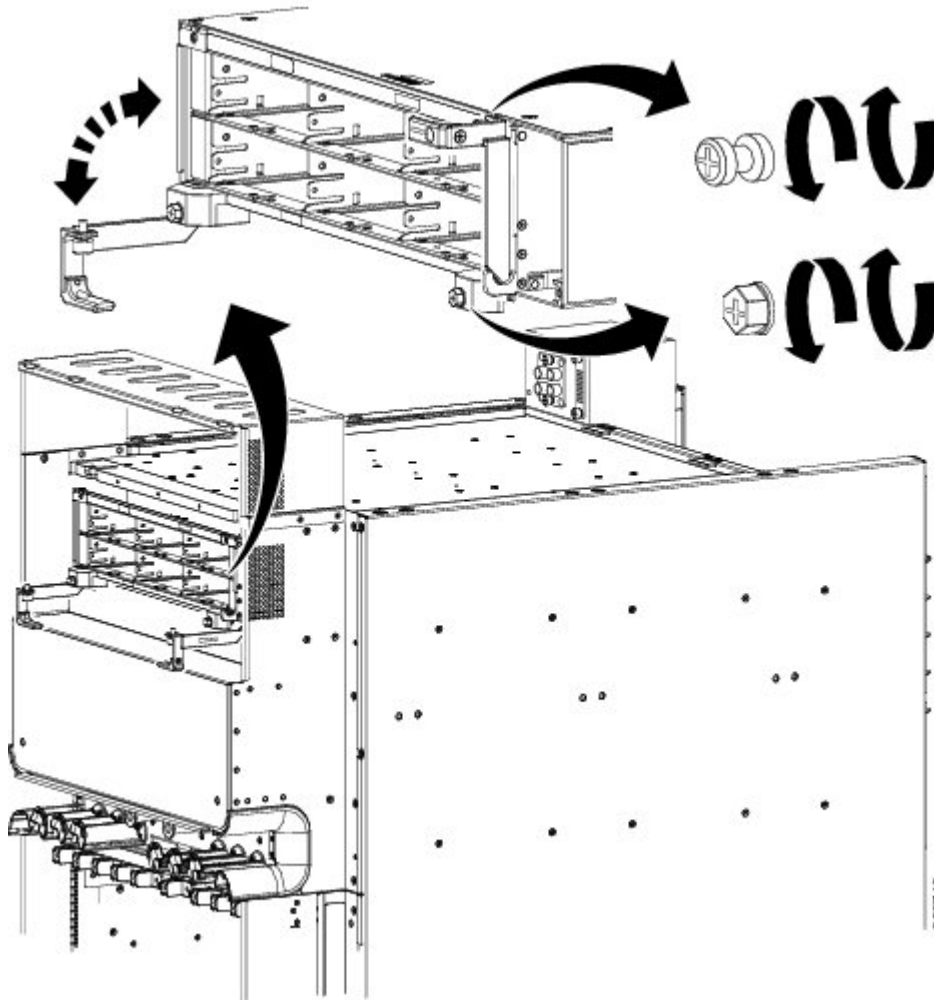
1

Power shelf being installed

**Step 4** Grasping both handles simultaneously, push both the left and right handles up and in at the same time to push the shelf into the chassis. Slide the shelf all the way into the chassis, until both power shelf handles hook around the pins.

**Caution** Make sure both handles swing straight up. Use care not to bend the handles sideways.

**Figure 27: Installing and Securing Power Shelf**



- Step 5** Using the screwdriver, tighten the captive screw on both power shelves. See [Figure 27: Installing and Securing Power Shelf, on page 47](#) Figure 3-20 .
- Step 6** Using the torque screwdriver, tighten the two screws that attach the bottom of the power shelf, one on each side, to the chassis to a torque value of 15 in.-lb (1.69 N m) to 20 in.-lb (2.26 N m). See [Figure 27: Installing and Securing Power Shelf, on page 47](#).
- Note** The screws that secure the power shelf to the chassis are relied upon for power shelf bonding and grounding.
- Step 7** Install the second power shelf, following through Step 3 through Step 6.

## What to Do Next

After the power shelves have been installed in the chassis, install the AC or DC power shelf wiring. Continue to the [Installing AC or DC Power Shelf Wiring](#), on page 48 for instructions.

## Installing AC or DC Power Shelf Wiring

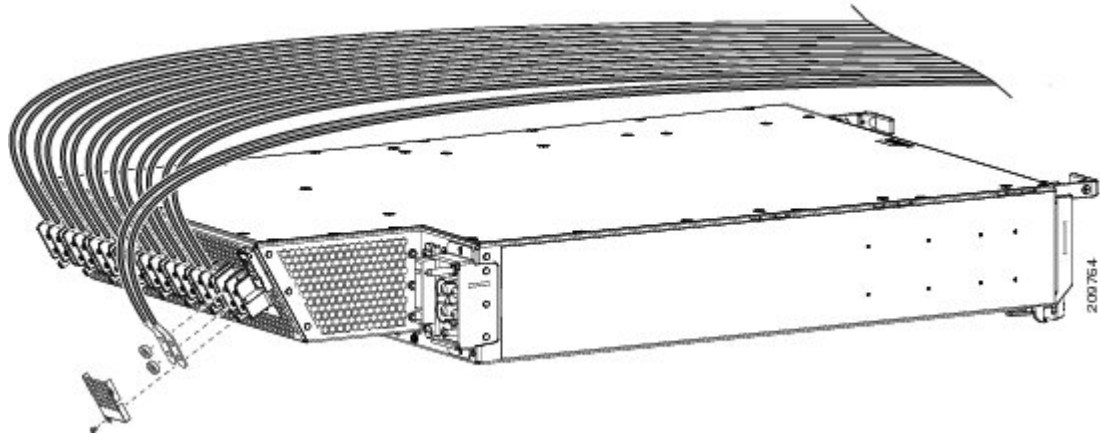
This section describes how to connect the DC input wiring and install the DC terminal block covers, or install the AC cords on the Cisco CRS Series Enhanced 16-slot Line Card Chassis. For complete information on regulatory compliance and safety, see *Regulatory Compliance and Safety Information for the Cisco CRS Carrier Routing System*.

### Installing DC Power Shelf Wiring

This section describes how to connect the DC input wiring to the rear of the power shelf and install the DC terminal block covers on the Cisco CRS Series Enhanced 16-slot Line Card Chassis.

[Figure 28: DC Power Shelf Cable Wiring for Power Shelf](#), on page 48 shows the cable wiring for the DC power shelf.

**Figure 28: DC Power Shelf Cable Wiring for Power Shelf**



For additional power shelf details, see the Cisco CSR-1 Series Carrier Routing System Description or [Appendix A, “Cisco CRS Series Carrier Routing System 16-Slot EC Line Card Chassis Specifications.”](#)



#### Note

When wiring the power shelf, be sure to connect the chassis ground cable first. For more information, see the [Bonding and Grounding Guidelines](#), on page 20 and the [Installing the Chassis Ground Cable](#), on page 37.

### Prerequisites

Before performing this task, perform the following procedures:

**Note**

Before installing wiring on the power shelf, make sure that the input power cables are not energized.

**Required Tools and Equipment**

You need the following tools to perform this task:

- DC power cables
- DC power cable lugs
- Crimping tool and lug specific die
- 3/8 in. ratchet wrench with 10-mm socket
- Multimeter
- Torque wrench with 10-mm 6 pt. socket and rated accuracy at 20 in.-lb (2.26 N-m)

**Steps**

To wire the DC power shelf, perform the following steps:

**SUMMARY STEPS**

1. Remove the terminal block covers, if installed.
2. Verify the following resistance values on both power shelves:
3. Use the crimping tool mandated by the lug manufacturer to crimp the lugs to the DC-input cables. For details on lugs, see the [DC Power Systems, on page 24](#).
4. Using the wrench, attach the positive and negative cable pairs to each terminal block on the upper power shelf (Power A). Start with PM0 (located on the right side) and move left, finishing with PM7 (located on the left side). Use the torque wrench to tighten to a torque of 20 in.-lb (2.26 N-m). Route the power cables for the upper power shelf to the left.
5. Using the wrench, attach the positive and negative cable pairs to each terminal block on the lower power shelf (Power B). Start with PM0 (located on the right side) and move left, finishing with PM7 (located on the left side). Use the torque wrench to tighten to a torque of 20 in.-lb (2.26 N-m). Route the power cables to the right.

**DETAILED STEPS**

**Step 1** Remove the terminal block covers, if installed.

**Step 2** Verify the following resistance values on both power shelves:

- The resistance between the positive and negative power terminal studs of each input must be greater than 90 KOhm.
- The resistance between each positive terminal stud and bare metal surface on the power shelf must be greater than 10MOhms.
- The resistance between each negative terminal stud and bare metal surface on the power shelf must be greater than 10MOhms.

- Note** Typical hand held Ohm meters will not measure 10MOhms, instead they will auto range to acquire a measurement and give an out-of-range reading. This is an acceptable reading provided that the meter is in calibration.
- Step 3** Use the crimping tool mandated by the lug manufacturer to crimp the lugs to the DC-input cables. For details on lugs, see the [DC Power Systems, on page 24](#).  
The cable should be sized according to local and national installation requirements. Use only copper cable.
- Note** The power supply terminal block lug width is 0.60 inch (1.50 cm). The terminal posts are centered 0.63 inches (5/8 inch) (1.60 cm) apart and are M6-threaded. We recommend that you use an appropriately sized 180-degree (straight) industry standard 2-hole, standard barrel compression lug.
- Step 4** Using the wrench, attach the positive and negative cable pairs to each terminal block on the upper power shelf (Power A). Start with PM0 (located on the right side) and move left, finishing with PM7(located on the left side). Use the torque wrench to tighten to a torque of 20 in.-lb (2.26 N-m). Route the power cables for the upper power shelf to the left.
- Step 5** Using the wrench, attach the positive and negative cable pairs to each terminal block on the lower power shelf (Power B). Start with PM0 (located on the right side) and move left, finishing with PM7(located on the left side). Use the torque wrench to tighten to a torque of 20 in.-lb (2.26 N-m). Route the power cables to the right.
- Note** Ensure cables are dressed correctly to ensure enough clearance to install the upper air grille.
- 

### What to Do Next

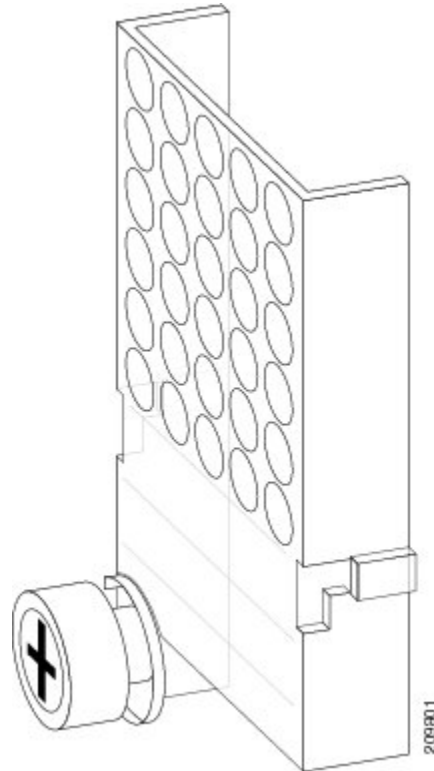
After the DC power shelf wiring has been installed, attach the terminal block covers. Continue to the [Installing DC Terminal Block Covers, on page 51](#) for instructions.



## Installing DC Terminal Block Covers

Figure 29: DC Terminal Block Cover, on page 51 shows the DC terminal block cover.

**Figure 29: DC Terminal Block Cover**



---

**Caution**

Install the terminal block cover after the input wiring is installed, but before power has been energized.

---

### Required Tools and Equipment

You need the following tools to perform this task:

- 6-in. long Number 1 Phillips screwdriver
- Terminal block covers
- Torque screwdriver with Number 1 Phillips head and a torque rating of 5 to 7 in.-lb

### Steps

To install the DC terminal block covers, go to the rear (MSC) side of the chassis and perform the following steps:

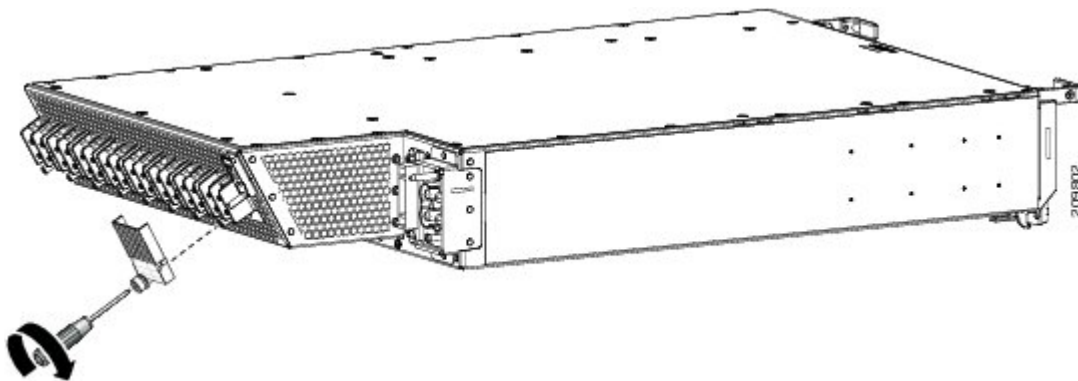
## SUMMARY STEPS

1. Align the DC terminal block cover with the cover latch tab.
2. Slide the terminal block cover upwards to align the screw with the mounting standoff.
3. Use the screwdriver to secure the screw into the mounting standoff, see [Figure 30: Securing the Terminal Block Cover](#), on page 52. Tighten to a torque of 5 to 7 in.-lb.

## DETAILED STEPS

- Step 1** Align the DC terminal block cover with the cover latch tab.
- Step 2** Slide the terminal block cover upwards to align the screw with the mounting standoff.
- Step 3** Use the screwdriver to secure the screw into the mounting standoff, see [Figure 30: Securing the Terminal Block Cover](#), on page 52. Tighten to a torque of 5 to 7 in.-lb.

*Figure 30: Securing the Terminal Block Cover*



## What To Do Next

After you install the DC input cables and DC terminal block cover, re-install the rear exhaust air deflector. Continue to the [Installing the Exhaust Air Deflector](#), on page 55 for instructions.

## Installing AC Power Cords

This section describes how to install input AC cords on the rear of the power shelf.



### Note

When installing AC power cords on the power shelf, be sure to connect the chassis ground cable first. For more information, see the [Bonding and Grounding Guidelines](#), on page 20 and the [Installing the Chassis Ground Cable](#), on page 37.

## Prerequisites

Before performing this task, perform the following procedures:

If you have AC Delta or AC Wye at your equipment, ensure that two *Cisco CRS PDUs* are installed to convert 3-phase AC input power to single-phase AC input power for the power shelves. For further information, refer to [Cisco CRS 3-Phase AC Power Distribution Unit Installation Guide](#) .



---

**Note**

If you have a Cisco CRS PDU installed, the AC power cords must be installed as labeled. For further information, refer to the *Cisco CRS 3-Phase AC Power Distribution Unit Installation Guide* .

---



---

**Note**

Before installing input AC power cords on the power shelf, make sure that the input power cords are not energized.

---

## Required Tools and Equipment

You need the following tools to perform this task:

- 6-in. long number 1 Phillips screwdriver
- Input AC power cords, depending on locale (Refer to [Appendix B, “Product IDs.”](#) )

## Steps

To install the input AC cord, go to the rear (MSC) side of the chassis and perform the following steps:

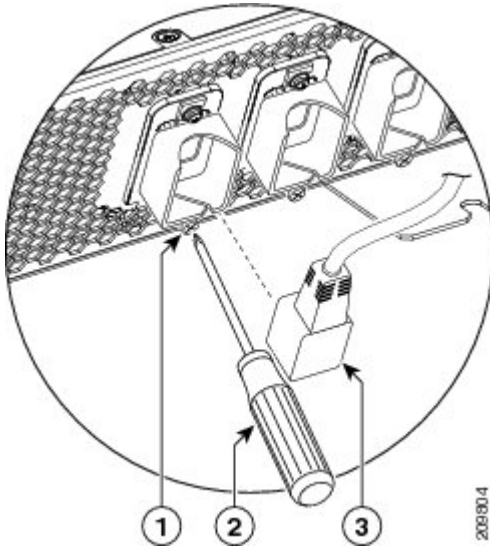
## SUMMARY STEPS

1. Insert the cord plug into the cord clamp (see [Figure 31: Cord Being Inserted into Cord Clamp, on page 54](#)) following the labeling on the phase assignments from the PDU or the labeling on the single phase power cords. As viewed from the front, the PDU on the right side is power shelf B and the PDU on the left side is power shelf A.
2. Use the screwdriver to secure the screw that clamps the cord plug in place, see [Figure 31: Cord Being Inserted into Cord Clamp, on page 54](#).

## DETAILED STEPS

- Step 1** Insert the cord plug into the cord clamp (see [Figure 31: Cord Being Inserted into Cord Clamp](#), on page 54) following the labeling on the phase assignments from the PDU or the labeling on the single phase power cords. As viewed from the front, the PDU on the right side is power shelf B and the PDU on the left side is power shelf A.

**Figure 31: Cord Being Inserted into Cord Clamp**



1	Screw that secures the cord clamp	3	Cord plug to be inserted into clamp
2	Screwdriver tightening screw		

- Step 2** Use the screwdriver to secure the screw that clamps the cord plug in place, see [Figure 31: Cord Being Inserted into Cord Clamp](#), on page 54.

### What To Do Next

After you install the AC input cords, re-install the rear exhaust air deflector. Continue to the [Installing the Exhaust Air Deflector](#), on page 55 for instructions.

## Installing the Exhaust Air Deflector

This section describes how to install the exhaust air deflector on the rear of the Cisco CRS Series Enhanced 16-slot Line Card Chassis. For complete information on regulatory compliance and safety, see *Regulatory Compliance and Safety Information for the Cisco CRS Carrier Routing System*.

### Prerequisites

Before performing this task, perform the following procedures:

### Required Tools and Equipment

You need the following tools and equipment to perform this task:

- 6-in. long number 2 Phillips screwdriver
- Rear exhaust air deflector (set aside earlier)

### Steps

To install the exhaust air deflector on the chassis, perform the following steps:

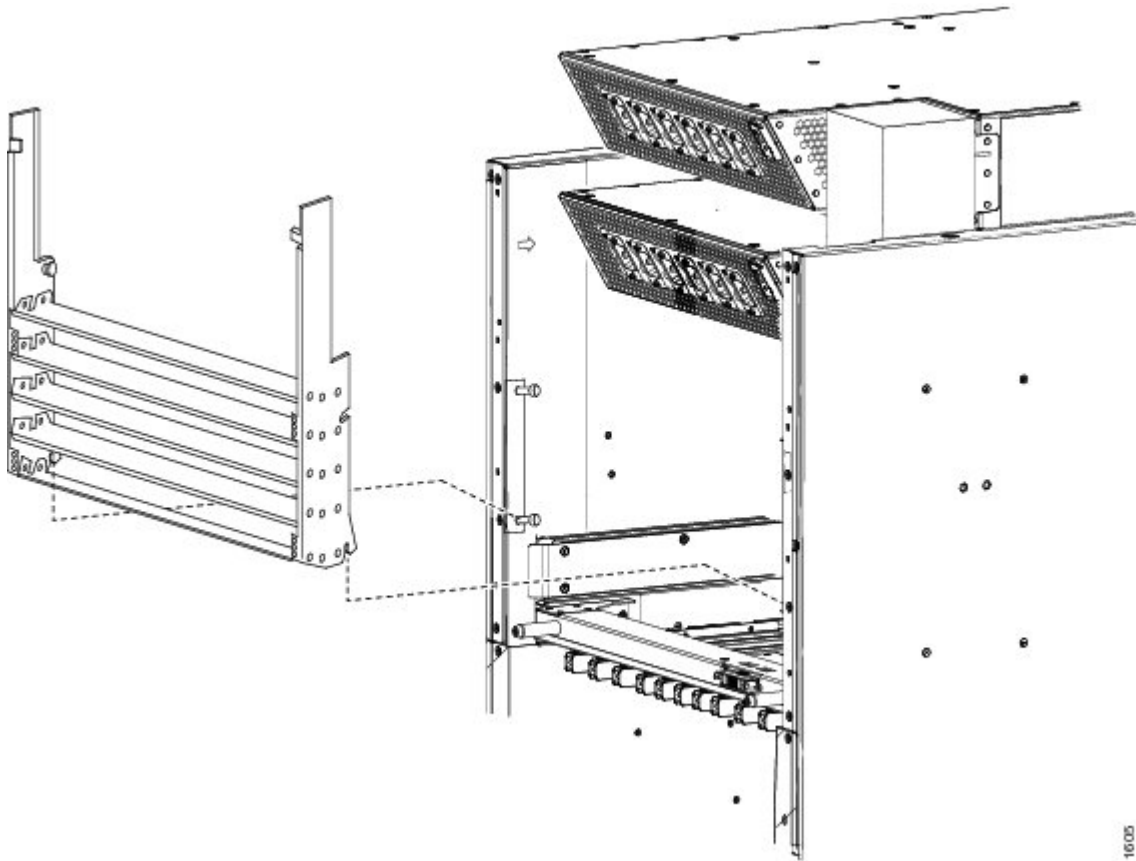
#### SUMMARY STEPS

1. Locate the mounting position standoffs on each side of the exhaust opening.
2. Position the lower cutouts on the bottom of the air deflector with the lower standoffs.
3. Rotate the air deflector forward until it is seated on the upper standoff.
4. Tighten the captive screw on both sides.

## DETAILED STEPS

- Step 1** Locate the mounting position standoffs on each side of the exhaust opening.
- Step 2** Position the lower cutouts on the bottom of the air deflector with the lower standoffs.

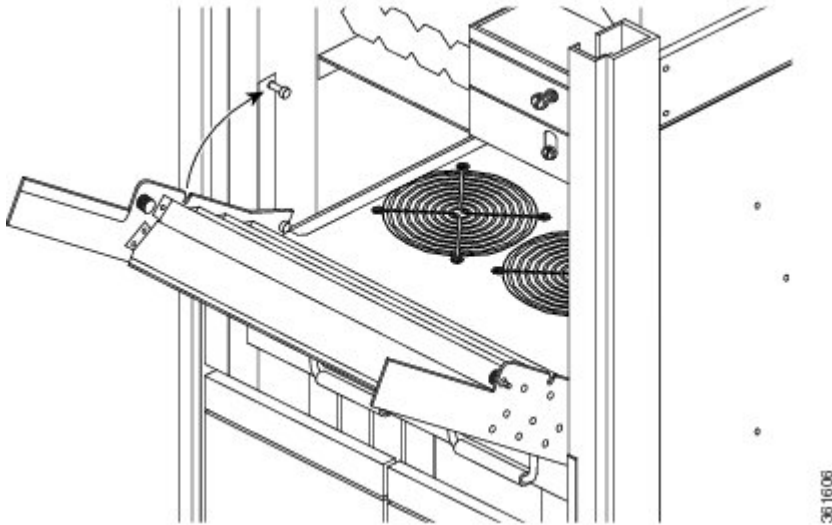
*Figure 32: Positioning the Lower Cutouts*



3616005

**Step 3** Rotate the air deflector forward until it is seated on the upper standoff.

**Figure 33: Rotating the Air Deflector Forward**



**Step 4** Tighten the captive screw on both sides.

**Figure 34: The Captive Screw**

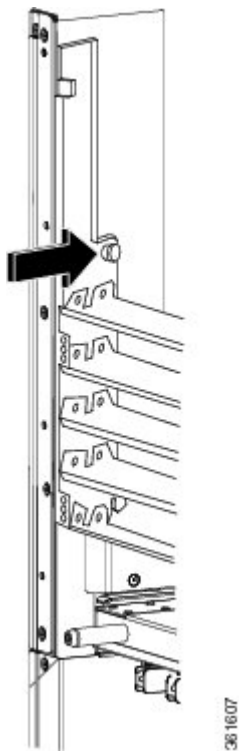
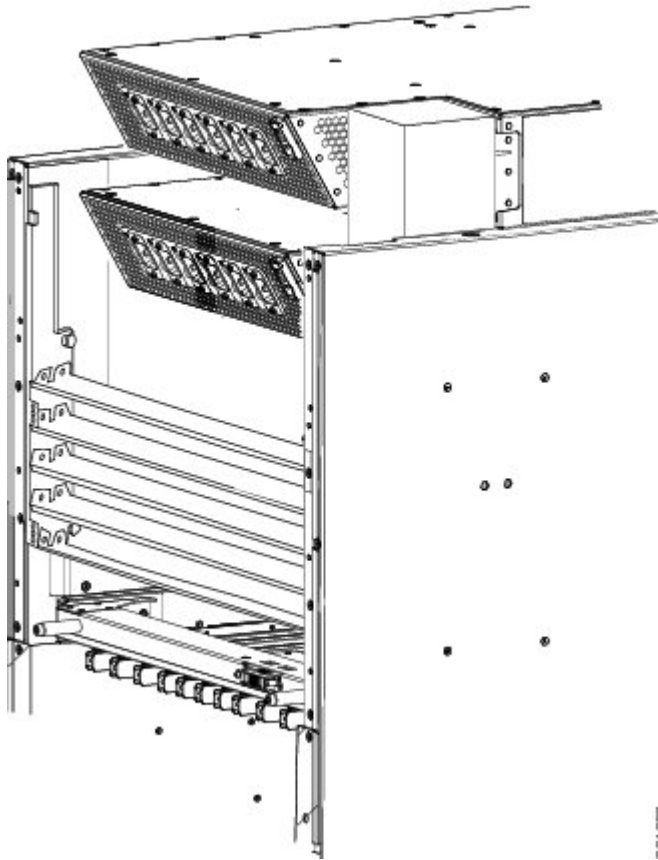


Figure 35: Installed Exhaust Air Deflector, on page 58 shows the exhaust air deflector installed on the chassis.

**Figure 35: Installed Exhaust Air Deflector**



## What to Do Next

After the exhaust air deflector has been re-installed on the rear (MSC) side of the chassis, install the alarm module and power modules in both power shelves. Continue to the [Installing an Alarm Module, on page 58](#) and the [Installing a Power Module, on page 63](#) for instructions.

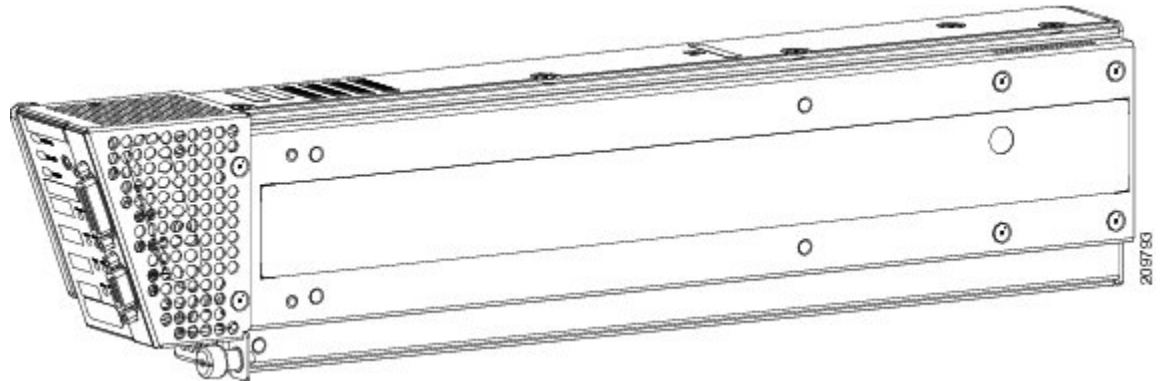
## Installing an Alarm Module

This section describes how to install the alarm modules in the power shelves in the Cisco CRS Series Enhanced 16-slot Line Card Chassis. For complete information on regulatory compliance and safety, see *Regulatory Compliance and Safety Information for the Cisco CRS Carrier Routing System*.



Figure 36: Alarm Module, on page 59 shows an alarm module.

**Figure 36: Alarm Module**



## Prerequisites

Before performing this task, perform the following procedures:



### Caution

Do not attempt to install the alarm module until the power shelf is in place and screwed into the chassis.

## Required Tools and Equipment

You need the following tools to perform this task:

- ESD-preventive wrist strap
- 6-in. long number 1 Phillips screwdriver
- Alarm module (Cisco product number CRS-16-ALARM-B=)

## Steps

To install the alarm module, perform the following steps:

## SUMMARY STEPS

1. Attach the ESD-preventive wrist strap to your wrist and connect its leash to one of the ESD connection sockets: on the front (PLIM) side of the chassis there is one ESD connection socket right above the fan controllers. On the rear (MSC) side of the chassis there are two ESD connection sockets right above the cable management tray in the center of the chassis (left and right). You can also connect the ESD-preventive wrist strap leash to any bare metal surface on the chassis.
2. Hold the alarm module such that the ejector handle is on the lower left front side. See [Figure 37: Installing Alarm Module in Power Shelf, on page 61](#).
3. Slide the alarm module into the bay on the right side of the power shelf. As you slide the module in, hold the ejector and gently push until it engages the chassis. See [Figure 37: Installing Alarm Module in Power Shelf, on page 61](#).
4. Continue to push the alarm module gently and rotate alarm module ejector upwards to seat the alarm module. Be careful not to pinch fingers between the ejector handle and the alarm module. See [Figure 38: Rotating Alarm Module Ejector Upwards to Seat Alarm Module, on page 62](#).
5. Hand tighten the captive screw on the lower right corner of the alarm module.
6. Use the number 1 Phillips screwdriver to securely fasten captive screw that secures the alarm module to the power shelf.

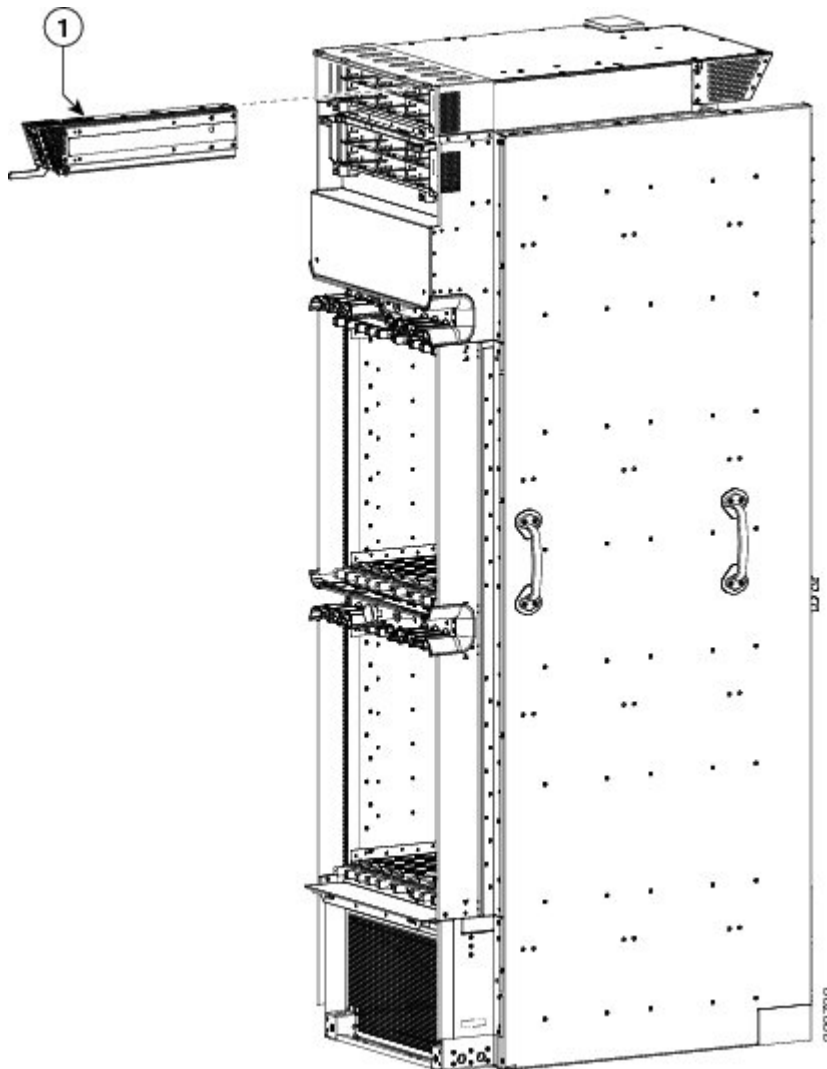
## DETAILED STEPS

- 
- Step 1** Attach the ESD-preventive wrist strap to your wrist and connect its leash to one of the ESD connection sockets: on the front (PLIM) side of the chassis there is one ESD connection socket right above the fan controllers. On the rear (MSC) side of the chassis there are two ESD connection sockets right above the cable management tray in the center of the

chassis (left and right). You can also connect the ESD-preventive wrist strap leash to any bare metal surface on the chassis.

- Step 2** Hold the alarm module such that the ejector handle is on the lower left front side. See [Figure 37: Installing Alarm Module in Power Shelf, on page 61](#).
- Step 3** Slide the alarm module into the bay on the right side of the power shelf. As you slide the module in, hold the ejector and gently push until it engages the chassis. See [Figure 37: Installing Alarm Module in Power Shelf, on page 61](#).

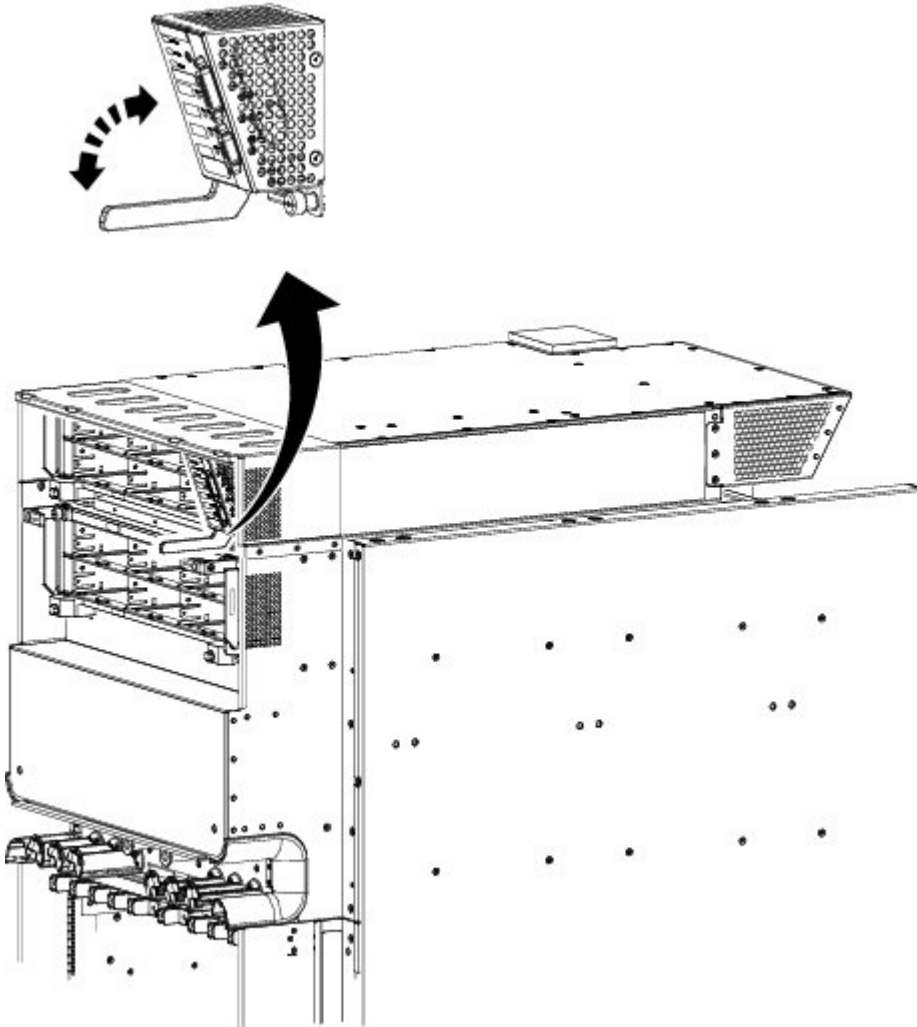
**Figure 37: Installing Alarm Module in Power Shelf**



1	Alarm module
---	--------------

- Step 4** Continue to push the alarm module gently and rotate alarm module ejector upwards to seat the alarm module. Be careful not to pinch fingers between the ejector handle and the alarm module. See [Figure 38: Rotating Alarm Module Ejector Upwards to Seat Alarm Module](#), on page 62.

**Figure 38: Rotating Alarm Module Ejector Upwards to Seat Alarm Module**



- Step 5** Hand tighten the captive screw on the lower right corner of the alarm module.
- Step 6** Use the number 1 Phillips screwdriver to securely fasten captive screw that secures the alarm module to the power shelf.

## What to Do Next

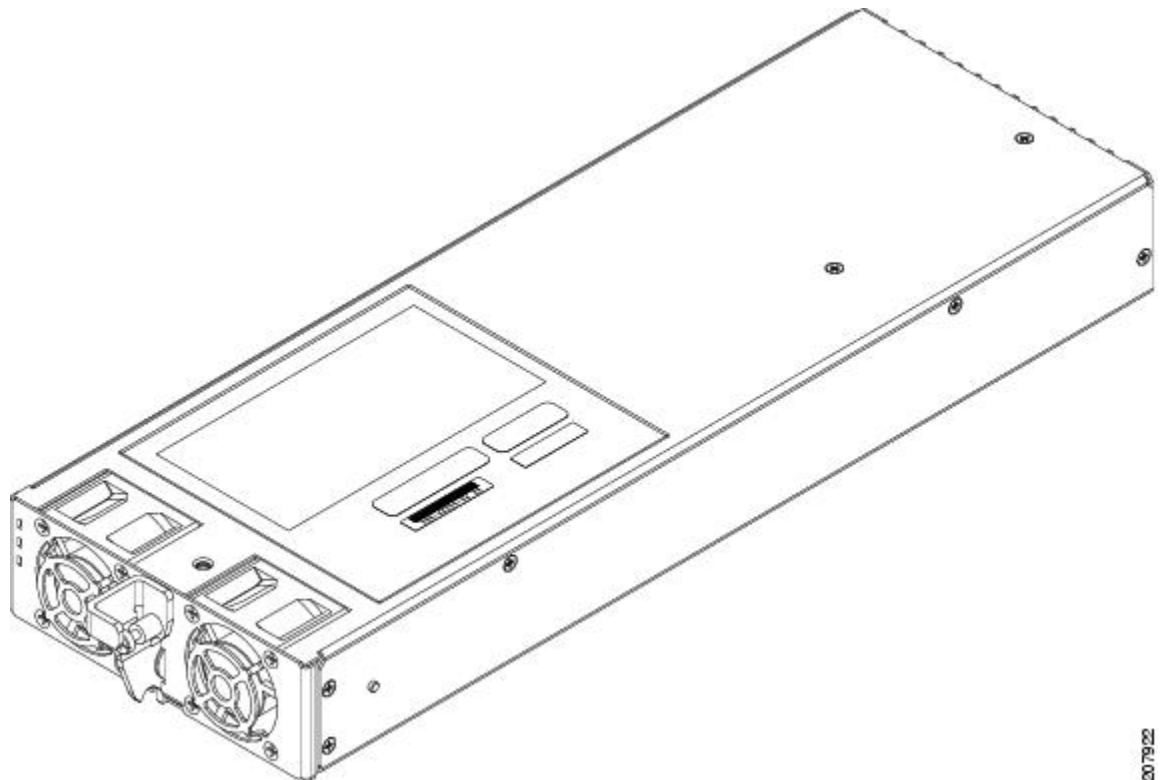
After the alarm modules are installed in the power shelves, install the AC or DC power modules. Continue to the [Installing a Power Module](#), on page 63 for instructions.

## Installing a Power Module

This section describes how to install the AC or DC PMs, shown in [Figure 39: Power Module, on page 63](#) , in the Cisco CRS Series Enhanced 16-slot Line Card Chassis. For complete information on regulatory compliance and safety, see *Regulatory Compliance and Safety Information for the Cisco CRS Carrier Routing System* .

Although there are differences between the AC and DC power modules, they are installed using the same procedures.

**Figure 39: Power Module**



0079/02

### Prerequisites

Before performing this task, perform the following procedures:

**Caution**

Do not attempt to install the PM until the power shelf is in place and screwed into the chassis.

### Required Tools and Equipment

You need the following tools to perform this task:

- ESD-preventive wrist strap
- 6-in. long number 1 Phillips screwdriver
- Torque screwdriver with number 1 Phillips bit and rated accuracy at 5.5 in.-lb (0.62 N-m)
- AC or DC PM
  - AC PM (Cisco product number CRS-PM-AC=), or
  - DC PM (Cisco product number CRS-PM-DC=)

## Steps

To install the PM in a power shelf, perform the following steps:

### SUMMARY STEPS

1. Attach the ESD-preventive wrist strap to your wrist and connect its leash to one of the ESD connection sockets: on the front (PLIM) side of the chassis there is one ESD connection socket right above the fan controllers. On the rear (MSC) side of the chassis there are two ESD connection sockets right above the cable management tray in the center of the chassis (left and right). You can also connect the ESD-preventive wrist strap leash to any bare metal surface on the chassis.
2. Using two hands to support and guide the PM, slide it into the power shelf. Install PM0 first.
3. Rotate the ejector lever upwards to seat the PM into the power shelf. Tighten the ejector lever to nominal install torque of 5.5 in.-lb (0.62 N m), screw the PM into the shelf (see [Figure 40: Securing the PM to the Shelf, on page 65](#)). Do not exceed a maximum install torque of 10 in.-lb (1.13 N-m).
4. Fill the power shelf, in PM ascending order, to the required configuration.

### DETAILED STEPS

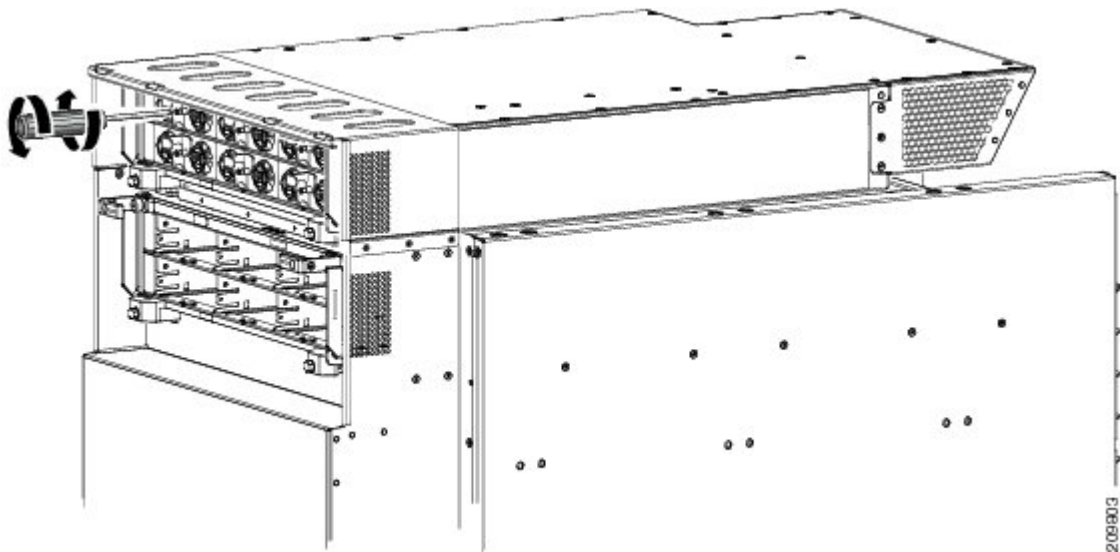
- 
- Step 1** Attach the ESD-preventive wrist strap to your wrist and connect its leash to one of the ESD connection sockets: on the front (PLIM) side of the chassis there is one ESD connection socket right above the fan controllers. On the rear (MSC) side of the chassis there are two ESD connection sockets right above the cable management tray in the center of the

chassis (left and right). You can also connect the ESD-preventive wrist strap leash to any bare metal surface on the chassis.

**Step 2** Using two hands to support and guide the PM, slide it into the power shelf. Install PM0 first.

**Step 3** Rotate the ejector lever upwards to seat the PM into the power shelf. Tighten the ejector lever to nominal install torque of 5.5 in.-lb (0.62 N m), screw the PM into the shelf (see [Figure 40: Securing the PM to the Shelf](#), on page 65). Do not exceed a maximum install torque of 10 in.-lb (1.13 N-m).

**Figure 40: Securing the PM to the Shelf**



**Step 4** Fill the power shelf, in PM ascending order, to the required configuration.

## What to Do Next

After performing this task, install power module slot covers into empty power module slots in the power shelf, if any. For more information, see the [Installing a Power Module Slot Cover](#), on page 65. Other wise, re-install the upper grille on the front (PLIM) side of the chassis, if applicable.

## Installing a Power Module Slot Cover

This section describes how to install power module slot covers, in empty power module slots in the power shelves installed in the Cisco CRS Series Enhanced 16-slot Line Card Chassis. For complete information on regulatory compliance and safety, see *Regulatory Compliance and Safety Information for the Cisco CRS Carrier Routing System*.

Although the AC and DC power module slot covers differ slightly in size, they are installed using the same procedures.

## Prerequisites

Before performing this task, you must first remove the upper grille on the front (PLIM) side of the chassis, if installed, and install the alarm module and power modules to the required configuration in each power shelf. See [Installing an Alarm Module, on page 58](#) and [Installing a Power Module, on page 63](#).

## Required Tools and Equipment

You need the following tools to perform this task:

- ESD-preventive wrist strap
- AC or DC PM Slot Cover
  - AC PM slot cover (Cisco product number 700–29097–xx), or
  - DC PM slot cover (Cisco product number 700–29098–xx)

## Steps

To install a PM slot cover in a power shelf, perform the following steps:

### SUMMARY STEPS

1. Attach the ESD-preventive wrist strap to your wrist and connect its leash to one of the ESD connection sockets: on the front (PLIM) side of the chassis there is one ESD connection socket right above the fan controllers. On the rear (MSC) side of the chassis there are two ESD connection sockets right above the cable management tray in the center of the chassis (left and right). You can also connect the ESD-preventive wrist strap leash to any bare metal surface on the chassis.
2. Align the PM slot cover with the empty PM slot in the power shelf.
3. Insert the two tabs on the right side of the PM slot cover into the two holes on the right side of the PM slot. See [Figure 41: Installing PM Slot Cover, on page 67](#).
4. Push the left side of the PM slot cover gently until it clicks into place. See [Figure 41: Installing PM Slot Cover, on page 67](#).

### DETAILED STEPS

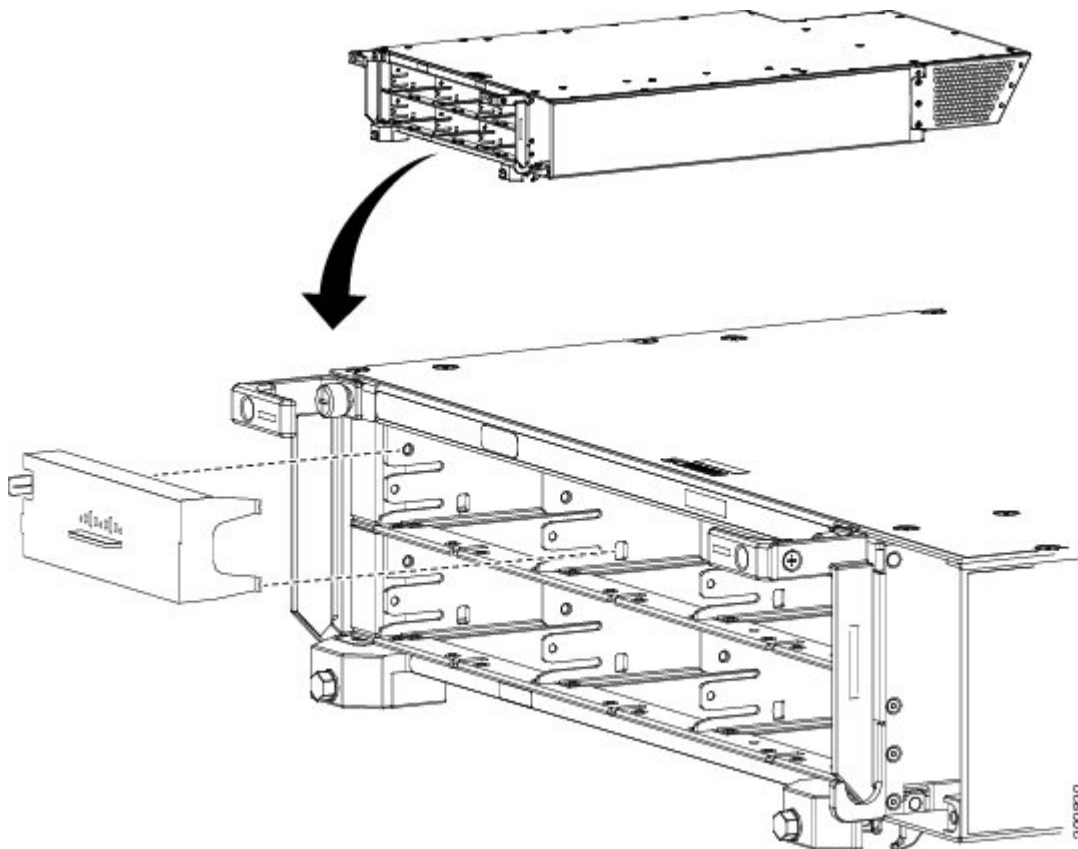
- 
- Step 1** Attach the ESD-preventive wrist strap to your wrist and connect its leash to one of the ESD connection sockets: on the front (PLIM) side of the chassis there is one ESD connection socket right above the fan controllers. On the rear (MSC) side of the chassis there are two ESD connection sockets right above the cable management tray in the center of the



chassis (left and right). You can also connect the ESD-preventive wrist strap leash to any bare metal surface on the chassis.

- Step 2** Align the PM slot cover with the empty PM slot in the power shelf.
- Step 3** Insert the two tabs on the right side of the PM slot cover into the two holes on the right side of the PM slot. See [Figure 41: Installing PM Slot Cover, on page 67](#).
- Step 4** Push the left side of the PM slot cover gently until it clicks into place. See [Figure 41: Installing PM Slot Cover, on page 67](#).

**Figure 41: Installing PM Slot Cover**



## What to Do Next

After performing this task, re-install the upper grille on the front (PLIM) side of the chassis, if applicable.

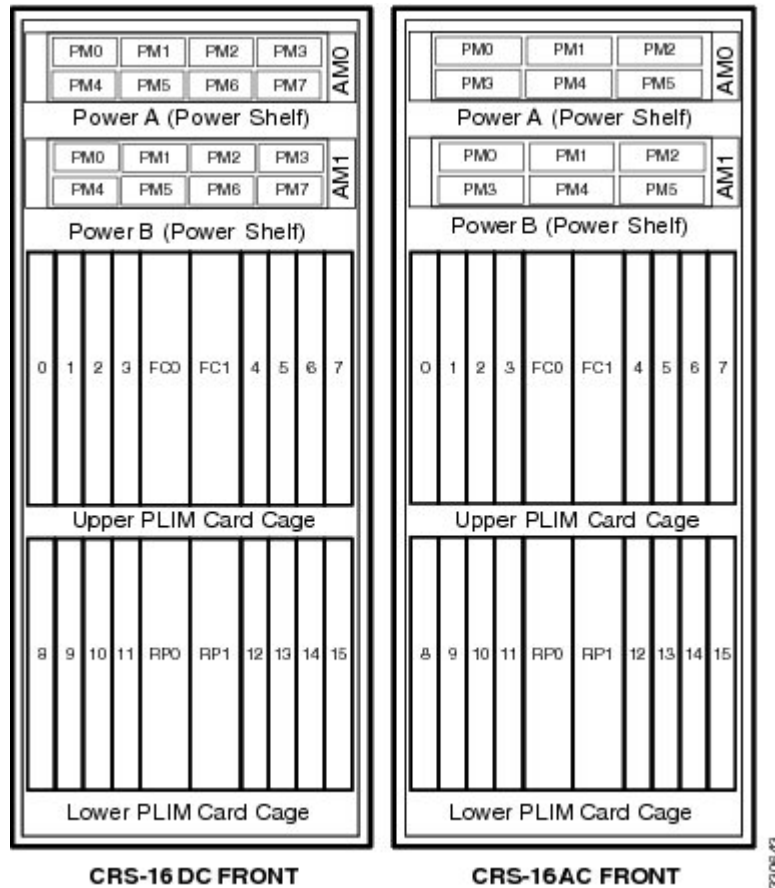
## Power Up and Power Down a Chassis

This section describes how to power up and power down a chassis with an AC or DC power shelf. For details on the chassis power systems, see the [Basic Chassis Power Details](#), on page 19, the [AC Power Systems](#), on page 26, and the [DC Power Systems](#), on page 24. For complete information on regulatory compliance and safety, see *Regulatory Compliance and Safety Information for the Cisco CRS Carrier Routing System*.

Most components on the chassis, such as the PMs, alarm modules, and fan trays, can be removed or installed in the chassis while it is running. Although it is possible to install or remove a power shelf while the chassis is running, it is recommended to remove power from the chassis completely, if possible, for service protection and safety.

[Figure 42: Cisco CRS Enhanced 16-Slot Line Card Chassis Front \(PLIM\) Side Slot Numbers](#), on page 68 shows the chassis slot number on the front (PLIM) side of the Cisco CRS Series Enhanced 16-slot Line Card Chassis with an AC and DC power system installed.

**Figure 42: Cisco CRS Enhanced 16-Slot Line Card Chassis Front (PLIM) Side Slot Numbers**



[Table 4: PM LED Status Indicator Lights](#), on page 69 shows the LED status indicator lights for the AC and DC PMs in a power supply.

**Table 4: PM LED Status Indicator LightS**

LED Name	Color	Function or Meaning
Input_OK	Green	On: The input voltage is present and within regulation range. Blinking: The input voltage is present but out of regulation range. Off: The input voltage is not present.
Output_OK	Green	On: The output voltage is on. Blinking: The PM is in a power limit or an OC condition. Off: The output voltage is off.
Internal Fault	Red	On: An internal fault is detected within the PM. Off: The PM has no internal fault.

## Power Up a Chassis

This section describes how to power up a chassis with AC or DC power shelves installed.

### Prerequisites

Before performing this task, perform the following procedures:

If you have a DC power system installed, wiring at the BDFB or at the power plant should be complete.

### Steps

To power on the chassis, perform the following steps:

## SUMMARY STEPS

1. Make sure all boards (RPs, PLIMs, SFCs, and FPs) are pulled-out and disconnected from the backplane. Verify that the three status LEDs on the front of each power module are off.
2. Make sure that I/O switches on the rear of the upper (Power A) and lower (Power B) power shelves are in the OFF position.
3. If you have a DC power system installed, perform the following steps:
4. If you have an AC power system installed, perform the following steps:
5. Verify that the fan tray and fan controller LEDs are on and that the fans are running.
6. Turn the I/O switch at the rear of both upper power shelves (Power A and Power B) to the OFF position. Verify that none of the Output\_OK LEDs on the PMs installed in the shelf are green.
7. Install all boards (RPs, PLIMs, SFCs, and FPs) in the chassis. For more information, see [Chapter 6, "Installing Line Cards, PLIMs, and Associated Components."](#)
8. Turn the I/O switch at the rear of both power shelves (Power A and Power B) to the ON position.

## DETAILED STEPS

- 
- Step 1** Make sure all boards (RPs, PLIMs, SFCs, and FPs) are pulled-out and disconnected from the backplane. Verify that the three status LEDs on the front of each power module are off.
- Step 2** Make sure that I/O switches on the rear of the upper (Power A) and lower (Power B) power shelves are in the OFF position.
- Step 3** If you have a DC power system installed, perform the following steps:
- a) Insert the power fuse at the BDFB or power plant to energize PM 0 on the upper power shelf, Power A.
  - b) Measure the voltage at the input terminal block and verify that the DC voltage between the positive and negative terminals is between 48 VDC and 60 VDC. Make a note of this voltage measurement.
 

**Caution** Make sure that the polarity of the DC input wiring is correct.

**Caution** This is a positive ground system; make sure to connect the positive lead to the +RTN terminal and the negative lead to the -48V terminal.
  - c) Verify that the correct Input OK LED on PM is lit.
  - d) Repeat Step a through Step c for each of the remaining DC inputs on the upper power shelf, Power A.
  - e) Repeat Step a through Step d for each of the DC inputs on the lower power shelf, Power B. When power shelf B has been completed go to Step 5.
- Step 4** If you have an AC power system installed, perform the following steps:
- a) Open the circuit breaker for each feed on the PDU (6) A and B or the 12 individual single phase inputs at the circuit breaker cabinet.
  - b) If you are using the Cisco AC PDU, connect the 3 phase Delta or Wye plug into the source outlet.
  - c) Energize the office three phase breakers for sides A and B.
  - d) Close PM 0 (AB) on the left side PDU (power shelf A) and verify that the In OK LED is on for the PM that is energized.
  - e) Repeat Step d for PMs 1-5 on side A and for PMs 0 - 6 side B.

- f) Close the power shelf output breaker for side A and verify that the Output LEDs are lit for PMs 0 - 5. Repeat for side B.

- Step 5** Verify that the fan tray and fan controller LEDs are on and that the fans are running.
- Step 6** Turn the I/O switch at the rear of both upper power shelves (Power A and Power B) to the OFF position. Verify that none of the Output\_OK LEDs on the PMs installed in the shelf are green.
- Step 7** Install all boards (RPs, PLIMs, SFCs, and FPs) in the chassis. For more information, see [Chapter 6, “Installing Line Cards, PLIMs, and Associated Components.”](#)
- Step 8** Turn the I/O switch at the rear of both power shelves (Power A and Power B) to the ON position.

### What to Do Next



**Note** For appropriate SFC LED information, see the appropriate section in [Chapter 6, “Installing Line Cards, PLIMs, and Associated Components.”](#) or the specific documentation for the card.

## Power Down a Chassis

This section describes how to power down a chassis with a AC or DC power shelf.

### Steps

To power down the chassis, perform the following steps:

#### SUMMARY STEPS

1. Turn the I/O switches at the rear of both power shelves, Power A and Power B, to the OFF position.
2. If you have a DC power system installed, remove the power fuse at the BDFB or power plant for each power module on both power shelves.
3. If you have an AC power system installed, turn off the source circuit breakers to de-energize the power modules in the upper and lower power shelves.

#### DETAILED STEPS

- Step 1** Turn the I/O switches at the rear of both power shelves, Power A and Power B, to the OFF position.
- Note** There is no required order in which you must turn off the power shelves.
- Step 2** If you have a DC power system installed, remove the power fuse at the BDFB or power plant for each power module on both power shelves.
- Step 3** If you have an AC power system installed, turn off the source circuit breakers to de-energize the power modules in the upper and lower power shelves.
- Note** All DC power cables or AC power cords must be de-energized to fully remove power from the chassis.





# Installing and Removing Air Circulation Components

This chapter provides instructions on how to install and replace the Cisco CRS Series Enhanced 16-Slot Line Card Chassis air circulation components.



**Note**

---

The chassis is shipped with the fan trays and air filter pre-installed.

---

This chapter presents the following topics:

- [Information About the Air Circulation Components, page 73](#)
- [How to Replace Air Circulation Components, page 75](#)

## Information About the Air Circulation Components

This section contains some general information about the air circulation components in the following topics:

### About the Fan Trays

The Cisco CRS Series Enhanced 16-Slot Line Card Chassis has two fan trays (see [Figure 43: Airflow Through the Cisco CRS Series Enhanced 16-Slot Line Card Chassis, on page 74](#)), one just below the lower card cage and the other just above the upper card cage. The chassis can run with only one fan tray operating. If a failure occurs in one fan tray, the other fan tray acts as the redundant fan tray to assure fault-tolerant system performance; the chassis continues to operate while the failed fan tray is replaced.

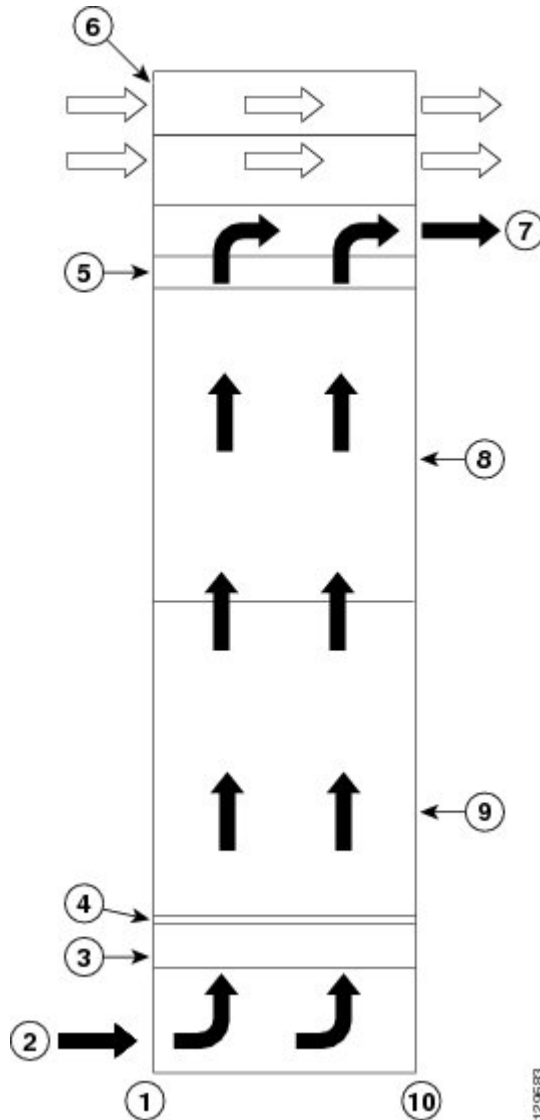
The Cisco CRS Series Enhanced 16-Slot Line Card Chassis fan tray operates in either the upper or lower fan tray slots. Each fan tray installs into the rear (MSC) side of the chassis and contains:

- Nine fans
- Fan tray board
- Front-panel status LED

**Note**

The upper and lower fan trays are interchangeable and installed in the same manner.

**Figure 43: Airflow Through the Cisco CRS Series Enhanced 16-Slot Line Card Chassis**



1	Front (PLIM) side of chassis	6	Power shelves (two installed)
2	Air intake	7	Air exhaust
3	Lower fan tray	8	Upper card cage
4	Air filter	9	Lower card cage



5	Upper fan tray	10	Rear [MSC] side of chassis
---	----------------	----	----------------------------

## About the Air Filter

The chassis has a serviceable air filter mounted in a slide-out tray accessible from the rear of the chassis just below the lower card cage (see [Figure 43: Airflow Through the Cisco CRS Series Enhanced 16-Slot Line Card Chassis, on page 74](#)). The air filter removes dust from the room air drawn into the router by the two fan trays. Once a month (or more often in dusty environments) you should examine the air filter and replace it if it appears damaged or excessively dirty.



### Caution

Periodic maintenance of the air filter is required to maintain proper air flow in the system as well as to avoid optical contamination. It is highly recommended to clean air filters once in three months and also replace the air filter once in a year.

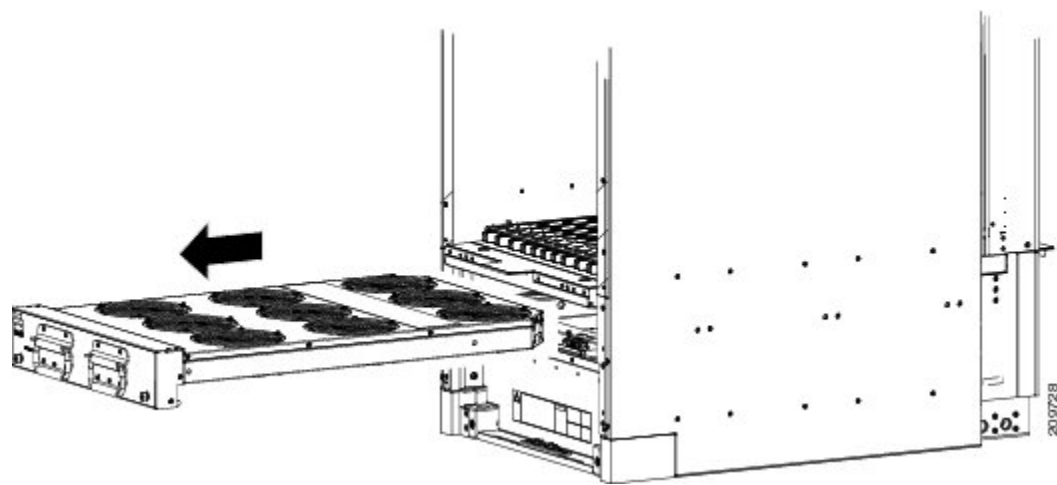
## How to Replace Air Circulation Components

This section contains the following procedures:

### Replacing a Fan Tray

This section describes how to replace a fan tray (see Fan Tray figure below) in the Cisco CRS Series Enhanced 16-Slot Line Card Chassis. For information on the fan tray, see the [Information About the Air Circulation Components, on page 73](#). For complete information on regulatory compliance and safety, see *Regulatory Compliance and Safety Information for the Cisco CRS Carrier Routing System*.

**Figure 44: Fan Tray**



## Prerequisites

Before performing this task, you must first open the chassis doors on the rear (MSC) side of the chassis, if installed. If you are replacing the upper fan tray, you must remove the upper grille from the rear (MSC) side of the chassis. If you are replacing the lower fan tray, you must remove the lower chassis cosmetic bezel from the rear (MSC) side of the chassis.

## Required Tools and Equipment

You need the following tools and part to perform this task:

- ESD-preventive wrist strap
- 6-in. long number 1 Phillips screwdriver
- Fan tray—Cisco product number CRS-16-FANTRAY

## Steps

To replace a fan tray, follow these steps:

### SUMMARY STEPS

1. Attach the ESD-preventive wrist strap to your wrist and connect its leash to one of the ESD connection sockets: on the front (PLIM) side of the chassis there is one ESD connection socket right above the fan controllers. On the rear (MSC) side of the chassis there are two ESD connection sockets right above the cable management tray in the center of the chassis (left and right). You can also connect the ESD-preventive wrist strap leash to any bare metal surface on the chassis.
2. Using the screwdriver, loosen the two captive screws on the fan tray faceplate. If necessary, use a step platform to reach the upper fan tray comfortably.
3. Pull firmly on the two handles to pull it free; two people are required to remove the fan tray.
4. Grasp the fan tray handles and pull it straight out to disconnect the fan tray from the connector mounted on the front of the fan tray bay on the rear (MSC) side of the chassis. Slide the fan tray halfway from the fan tray bay.
5. Use your free hands to support the fan tray, then slide the fan tray completely from the fan tray bay.
6. Set the fan tray carefully aside.
7. To install the replacement fan tray using two hands to support it, position the fan tray in front of the fan tray bay (label is on top).
8. Slide the fan tray into the fan tray bay. Stop when the fan tray makes contact with the chassis connector in the back of the fan tray bay.
9. Firmly push on the fan tray handles to seat the fan tray connector in the chassis connector. When completely seated, the fan tray faceplate flanges meet the rear (MSC) side of the chassis.
10. Tighten the two captive screws on the fan tray faceplate.

## DETAILED STEPS

**Step 1** Attach the ESD-preventive wrist strap to your wrist and connect its leash to one of the ESD connection sockets: on the front (PLIM) side of the chassis there is one ESD connection socket right above the fan controllers. On the rear (MSC) side of the chassis there are two ESD connection sockets right above the cable management tray in the center of the chassis (left and right). You can also connect the ESD-preventive wrist strap leash to any bare metal surface on the chassis.

**Step 2** Using the screwdriver, loosen the two captive screws on the fan tray faceplate. If necessary, use a step platform to reach the upper fan tray comfortably.

*Figure 45: Unscrewing the Screws in the Fan Tray Faceplate*



**Step 3** Pull firmly on the two handles to pull it free; two people are required to remove the fan tray.

**Caution** Because of the weight of the fan tray, approximately 37.5 lb (17 kg), two people are required to remove the fan tray. You should be especially careful while removing the fan tray from the chassis. To prevent injury, keep your back straight and lift with your legs, not your back. Avoid sudden twists or lateral moves. It is safer to use two people to remove the fan tray rather than a single person.

**Step 4** Grasp the fan tray handles and pull it straight out to disconnect the fan tray from the connector mounted on the front of the fan tray bay on the rear (MSC) side of the chassis. Slide the fan tray halfway from the fan tray bay.

**Step 5** Use your free hands to support the fan tray, then slide the fan tray completely from the fan tray bay.

**Step 6** Set the fan tray carefully aside.

**Step 7** To install the replacement fan tray using two hands to support it, position the fan tray in front of the fan tray bay (label is on top).

**Caution** Because of the weight of the fan tray, approximately 37.5 lb (17 kg), two people are required to replace the fan tray. You should be especially careful while replacing the fan tray into the chassis. To prevent injury, keep your back straight and lift with your legs, not your back. Avoid sudden twists or lateral moves. It is safer to use two people to support the fan tray while replacing it in the fan tray bay rather than a single person.

**Step 8** Slide the fan tray into the fan tray bay. Stop when the fan tray makes contact with the chassis connector in the back of the fan tray bay.

**Caution** To prevent damage to the chassis connector, do not use excessive force when inserting a fan tray into its bay.

**Step 9** Firmly push on the fan tray handles to seat the fan tray connector in the chassis connector. When completely seated, the fan tray faceplate flanges meet the rear (MSC) side of the chassis.

**Note** All electrical and control line connections are made automatically when the connectors mate. The Fan LED will light when the fan tray is inserted.

**Step 10** Tighten the two captive screws on the fan tray faceplate.

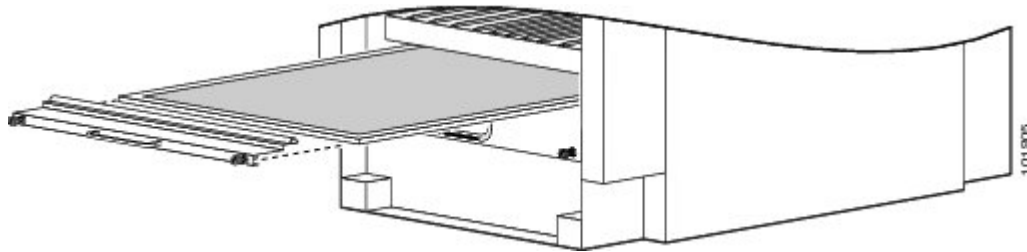
## What to Do Next

After performing this task, close the doors (if installed) and re-install the upper grille or lower chassis cosmetic bezel on the rear (MSC) side of the chassis, as necessary. For more information, see the [Installing the Rear \(MSC\) Side Cosmetic Components](#), on page 97.

## Replacing the Air Filter

This section describes how to replace the air filter in the Cisco CRS Series Enhanced 16-Slot Line Card Chassis. For further information, see the [Information About the Air Circulation Components](#), on page 73. For complete information on regulatory compliance and safety, see *Regulatory Compliance and Safety Information for the Cisco CRS Carrier Routing System*.

**Figure 46: Air Filter**



**Note**

A lattice of wire exists on both sides of the filter material with an arrow denoting airflow direction and a pair of sheet metal straps on the downstream side of the filter assembly.

### Prerequisites

Before performing this task, you must first open the doors and remove the lower grille on the Rear (MSC) side of the chassis. See the [Removing the Rear \(MSC\) Side Cosmetic Components](#), on page 195 for more information.



**Caution**

Never operate the Cisco CRS Series Enhanced 16-Slot Line Card Chassis without an air filter. Operating a Cisco CRS Series Enhanced 16-Slot Line Card Chassis without a filter or leaving an air filter cover off for an extended time can result in damage to the hardware.

### Required Tools and Equipment

You need the following tools and part to perform this task:

- ESD-preventive wrist strap
- 6-in. long number 1 Phillips screwdriver
- Air filter—Cisco product number CRS-16-FILTER

### Steps

To replace the air filter, perform the following steps:

## SUMMARY STEPS

1. Attach the ESD-preventive wrist strap to your wrist and connect its leash to one of the ESD connection sockets on the front (PLIM) side of the chassis or a bare metal surface on the chassis.
2. Using the screwdriver, loosen the two captive screws on the filter cover faceplate. Pull firmly on the cover to swing it free; some force may be required.
3. Insert the new air filter on top of the existing (old) air filter and push the new air filter into the air filter slot until it is seated fully within the slot.
4. Grasp the tabs at the front of the existing (old) air filter beneath the new air filter and carefully slide it from the slot.
5. Set this old air filter carefully aside.
6. Replace the filter cover and tighten the two captive screws on the front.

## DETAILED STEPS

- 
- |               |  |
|---------------|--|
| <b>Step 1</b> | Attach the ESD-preventive wrist strap to your wrist and connect its leash to one of the ESD connection sockets on the front (PLIM) side of the chassis or a bare metal surface on the chassis. |
| <b>Step 2</b> | Using the screwdriver, loosen the two captive screws on the filter cover faceplate. Pull firmly on the cover to swing it free; some force may be required.                                     |
| <b>Step 3</b> | Insert the new air filter on top of the existing (old) air filter and push the new air filter into the air filter slot until it is seated fully within the slot.                               |
| <b>Step 4</b> | Grasp the tabs at the front of the existing (old) air filter beneath the new air filter and carefully slide it from the slot.  |
| <b>Step 5</b> | Set this old air filter carefully aside.   |
| <b>Step 6</b> | Replace the filter cover and tighten the two captive screws on the front.  |
- 

## What to Do Next

After performing this task, re-install the lower grille and close the doors on the Rear (MSC) side of the chassis. For more information, see the [Installing the Rear \(MSC\) Side Cosmetic Components](#), on page 97.





## Installing Exterior Cosmetic Components

---

This chapter provides instructions on how to install the Cisco CRS Enhanced 16-slot line card chassis exterior cosmetic components.

This chapter presents the following topics:

- [Information About Exterior Cosmetic Components, page 81](#)
- [Installing the Front \(PLIM\) Side Exterior Cosmetic Components, page 86](#)
- [Installing the Rear \(MSC\) Side Cosmetic Components, page 97](#)
- [Attaching the Upper Rear Air Grille and Rear Kick Plate Without Vertical Troughs, page 104](#)

### Information About Exterior Cosmetic Components

This section contains some general information about the exterior cosmetic components.

The Cisco CRS Series enhanced 16-slot line card chassis is shipped with exterior cosmetic components for the front (PLIM) side and rear (MSC) side of the chassis.



**Note**

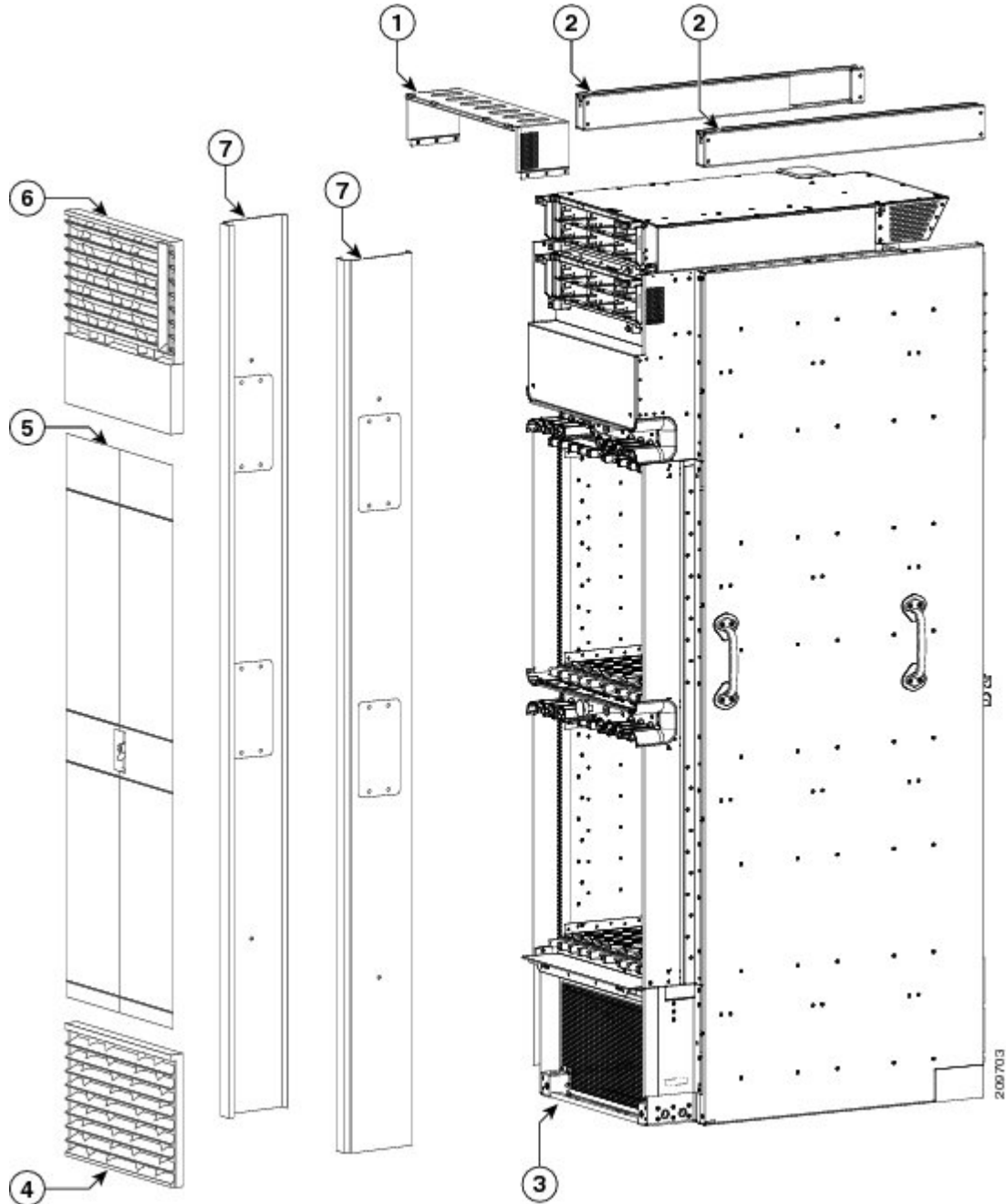
---

Some exterior cosmetic components, such as the cable pass-through accessory plates, are not required to be installed.

---

This figure shows the default exterior cosmetic components for the front (PLIM) side of a Cisco CRS Series enhanced 16-slot line card chassis.

**Figure 47: Default Front (PLIM) Side Exterior Cosmetic Components**



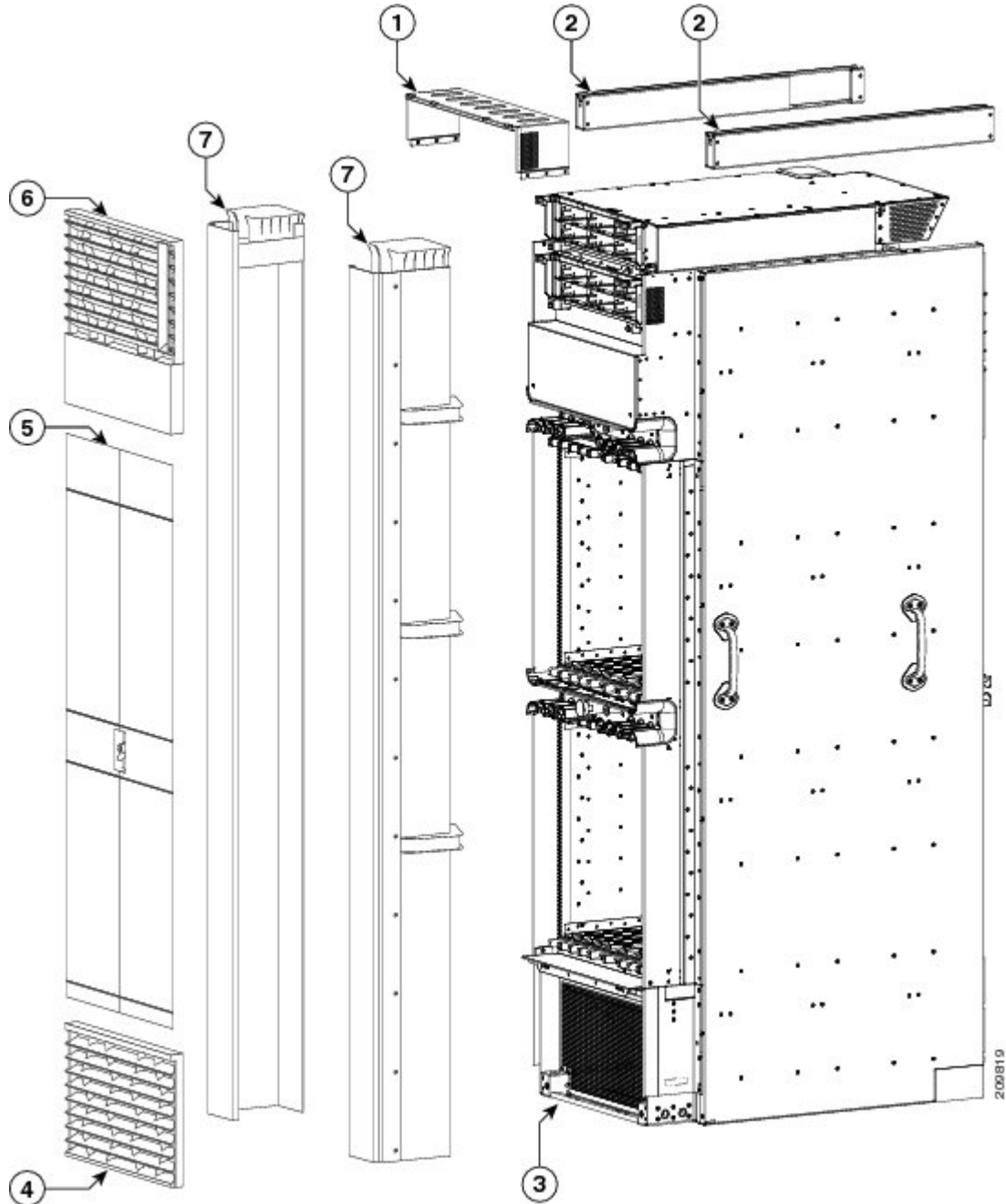
1	Upper grille support	5	Doors
2	Unistruts	6	Upper grille



3	Bracket for lower grille	7	Vertical cable troughs
4	Lower grille		

This figure shows the exterior cosmetic components for the front (PLIM) side of a Cisco CRS Series enhanced 16-slot line card chassis installed as part of a wide duct system.

**Figure 48: Front (PLIM) Side Exterior Cosmetic Components—Wide Duct System**

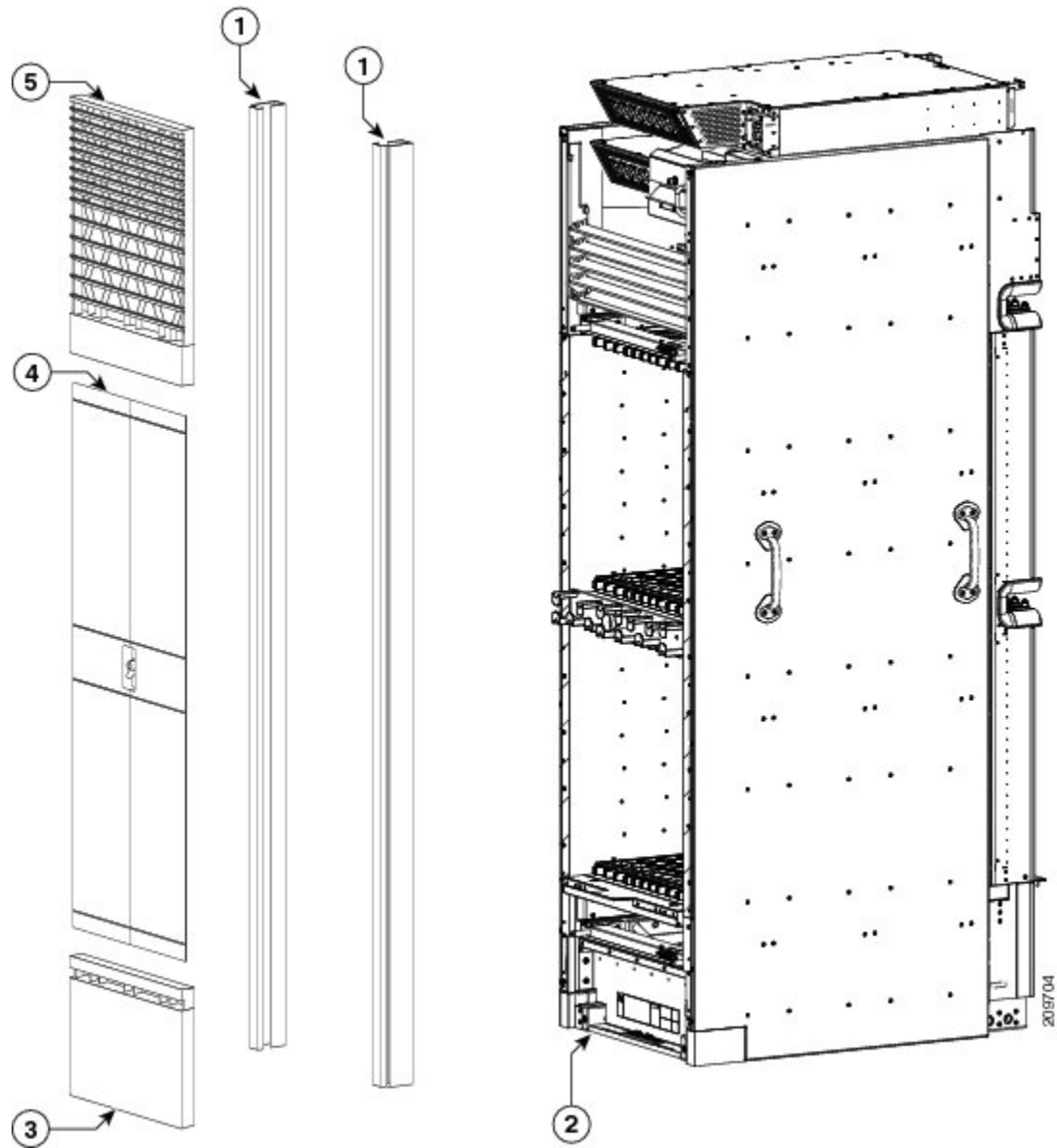


1	Upper grille support	5	Doors
2	Unistruts	6	Upper grille

3	Bracket for lower grille	7	Wide vertical cable troughs
4	Lower grille		

This figure shows the exterior cosmetic components for the rear (MSC) side of a Cisco CRS Series enhanced 16-slot line card chassis.

**Figure 49: Rear (MSC) Side Exterior Cosmetic Components**



1	Vertical cable trough	4	Doors
2	Bracket for optional rear kick panel	5	Upper air grille
3	Rear kick panel (optional, orderable separately)		

## Installing the Front (PLIM) Side Exterior Cosmetic Components

This section describes how to install the default front (PLIM) side exterior cosmetic components ([Figure 47: Default Front \(PLIM\) Side Exterior Cosmetic Components](#), on page 82) on the Cisco CRS Series enhanced 16-slot line card chassis.



### Note

While it is possible to install the various exterior components on the Cisco CRS Series enhanced 16-slot line card chassis in a different order, it is easier to install them in the order outlined in this section.

The lower grille screen and frame assembly are shipped pre-installed in the chassis. The upper grille support is not shipped pre-installed on the chassis but must be installed before the power shelves are installed in the chassis. For more information, see the [Installing the Upper Grille Support](#), on page 33

This section describes how to perform the following tasks:

## Prerequisites

Before performing this task, you must first unpack and secure the chassis. See the *Cisco CRS Carrier Routing System 16-Slot Line Card Chassis Unpacking, Moving, and Securing Guide*.

The upper grille support should already be installed at the top of the chassis. See the [Installing the Upper Grille Support](#), on page 33 for more information.

## Required Tools and Equipment

You need the following tools and parts to perform this task:

- 8-in. long number 1 Phillips screwdriver—magnetic head preferable, bit size #1
- 3/8-in. drive ratchet wrench
- Default vertical cable troughs (Cisco product number 800-35625-xx [right], 800-35644-xx [left])
- Optional wide vertical cable troughs (Cisco product number 800-36457-xx [right], 800-36456-xx [left])
- Optional cable pass-through accessory kit (Cisco product number CRS-LCC-CM-COVER), used with default cosmetics
- Upper grille (Cisco product number 800-35465-xx)
- Lower grille (Cisco product number 800-35466-xx)

- Exterior doors kit (Cisco product number CRS-16-DOORS-F)

## Steps

To install front (PLIM) side exterior cosmetic components, perform the following steps:

### SUMMARY STEPS

1. Unpack all cosmetic parts to prepare for installation.
2. (Attaching the Default Front Vertical Cable Troughs) Attach the vertical cable troughs—one right and one left—to the front (PLIM) side of the chassis (see *Installing the Front Vertical Cable Troughs* figure below):
3. (Installing the Cable Pass-through Accessory Plates (Optional)—Default Cable Trough Only) Remove the blank plates by unscrewing the four screws on each one.
4. Attach the inner cut-out plates using the four screws provided. See the *Cut-Out Plates* figure.
5. Attach the outer cut-out plate using the four screws provided.
6. (Attaching the Optional Wide Front Vertical Cable Troughs (Optional Trough)). Attach the vertical cable troughs—one right and one left—to the front (PLIM) side of the chassis (see *Installing the Front Vertical Cable Troughs* above):
7. (Installing the Upper Grille) Attach the upper grille by carefully inserting the four tabs on the grille into the appropriate hook hanger brackets on the top of the upper grille support (see below figure).
8. Press the grille and bezel firmly against the chassis until it snaps onto the ball stud snaps.
9. (Attaching the Lower Grille) Attach the lower grille by carefully inserting the tabs on the grille into the brackets on the bottom of the inlet grille frame.
10. Press the lower grille firmly until it snaps onto the ball stud snaps.
11. (Attaching the Front Exterior Doors) Orient the doors so that the slot on the metal part in the middle of the doors is lined up with the tab on the vertical cable trough. The door will then drop into position. See the below figure.
12. Insert the screws into the appropriate screw holes in the doors, and use the screwdriver to tighten fully. There are 11 M4x8 screws on each side for the metal sections of the doors and six M4x8 screws on each side for the plexiglass section of the door.
13. Ensure that the doors are properly aligned.
14. For wide duct installations (see *Door Adjustments for Wide Trough Installation* figure below):

### DETAILED STEPS

**Step 1** Unpack all cosmetic parts to prepare for installation.

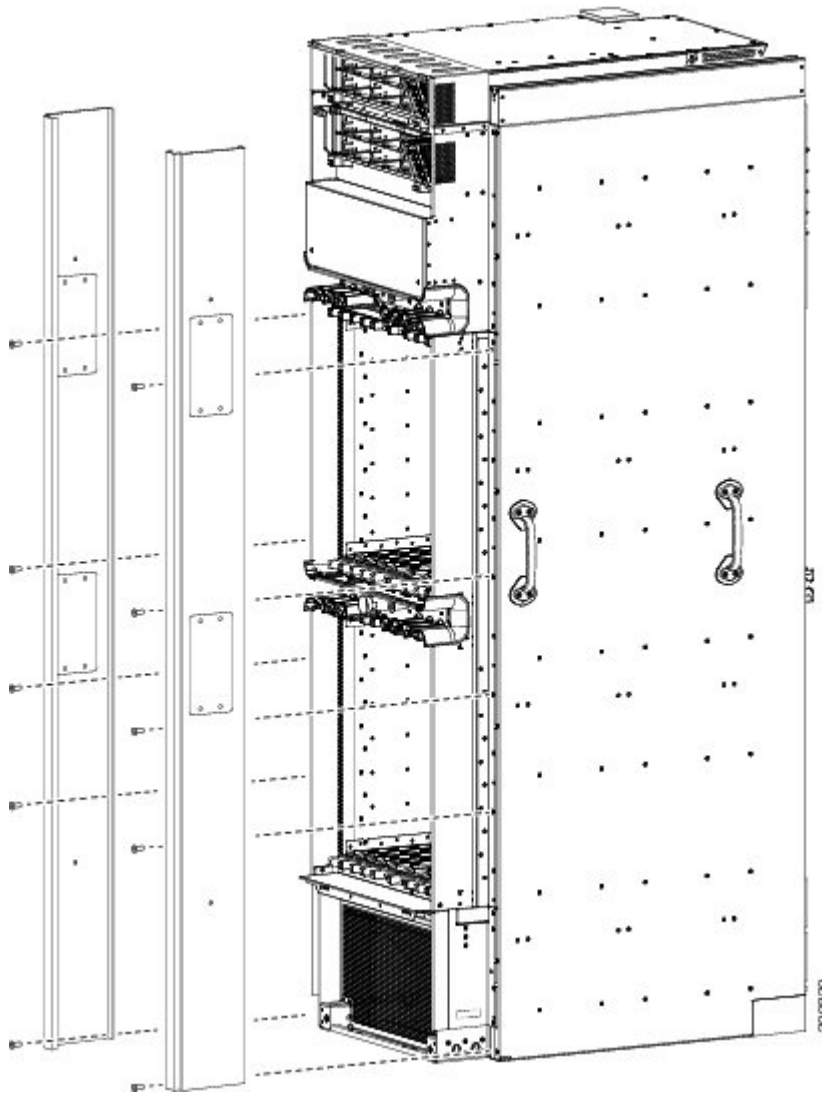
**Step 2** (Attaching the Default Front Vertical Cable Troughs) Attach the vertical cable troughs—one right and one left—to the front (PLIM) side of the chassis (see *Installing the Front Vertical Cable Troughs* figure below):

**Note** The part number for the right side vertical cable trough is 800-35625-xx; the part number for the left side vertical cable trough is 800-35644-xx.

- a) Tug all Velcro straps forward so that they are flush with the back side of the cable troughs (where the troughs attach to the chassis) to ensure that the troughs fit flush to the chassis.
- b) Insert the cable trough positioning studs into the guide slots on the unistrut, and let them slide down and lock into place.

- c) Insert the 10 M4x14-mm flat head screws (five on each trough) and use the screwdriver to turn the screws clockwise to attach the cable troughs firmly to the front of chassis.

**Figure 50: Installing the Front Vertical Cable Troughs**

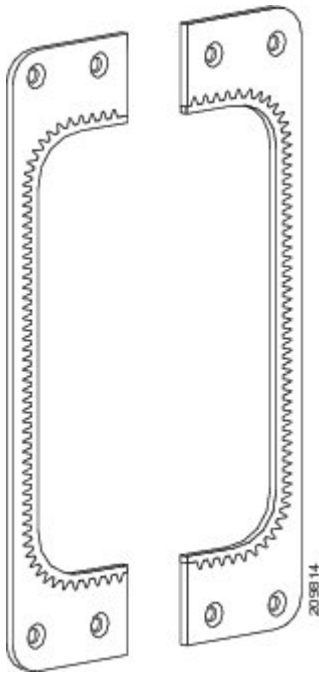


**Step 3** (Installing the Cable Pass-through Accessory Plates (Optional)—Default Cable Trough Only) Remove the blank plates by unscrewing the four screws on each one.

**Note** Depending on the size of the installation and the number and type of cables being used, the body of the chassis may become overcrowded and unable to accommodate all the required cables. To resolve this issue, you can install two pass-through accessory plates to allow cables be guided outside the default vertical troughs.

**Step 4** Attach the inner cut-out plates using the four screws provided. See the *Cut-Out Plates* figure.

**Figure 51: Cut-Out Plates**



**Step 5** Attach the outer cut-out plate using the four screws provided.

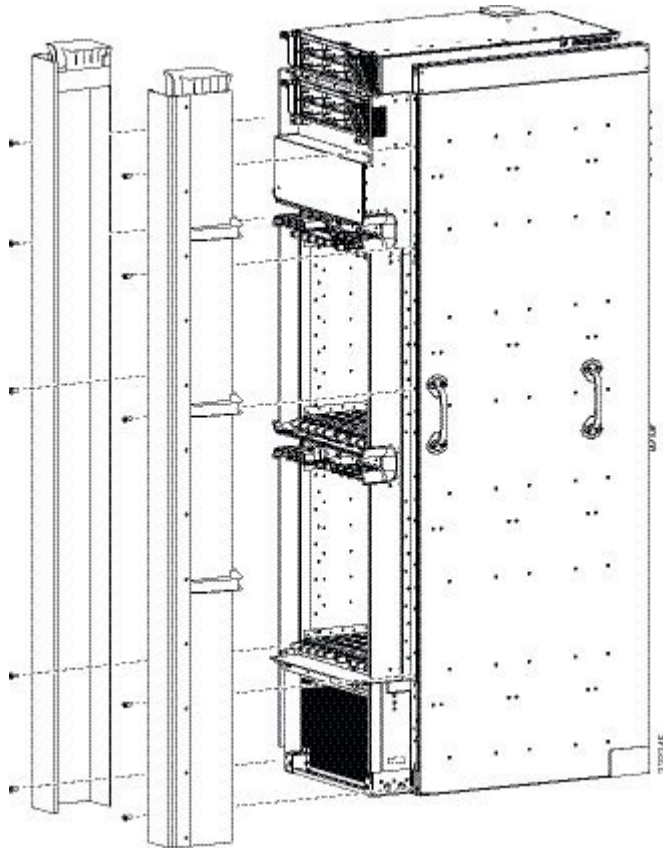
**Step 6** (Attaching the Optional Wide Front Vertical Cable Troughs (Optional Trough)). Attach the vertical cable troughs—one right and one left—to the front (PLIM) side of the chassis (see *Installing the Front Vertical Cable Troughs* above):

**Note** The part number for the right side vertical cable trough is 800-36457-xx; the part number for the left side vertical cable trough is 800-36456-xx.

- a) Tug all Velcro straps forward so that they are flush with the back side of the cable troughs (where the troughs attach to the chassis) to ensure that the troughs fit flush to the chassis.
- b) Insert the cable trough hooks into guide slots, and let them slide down and lock into place.

- c) Insert the ten M4x14-mm flat head screws (five on each side) and use the screwdriver to turn the screws clockwise to attach the cable troughs firmly to the front of the chassis. See the below figure .

**Figure 52: Attaching Wide Vertical Cable Troughs to Front of Chassis**

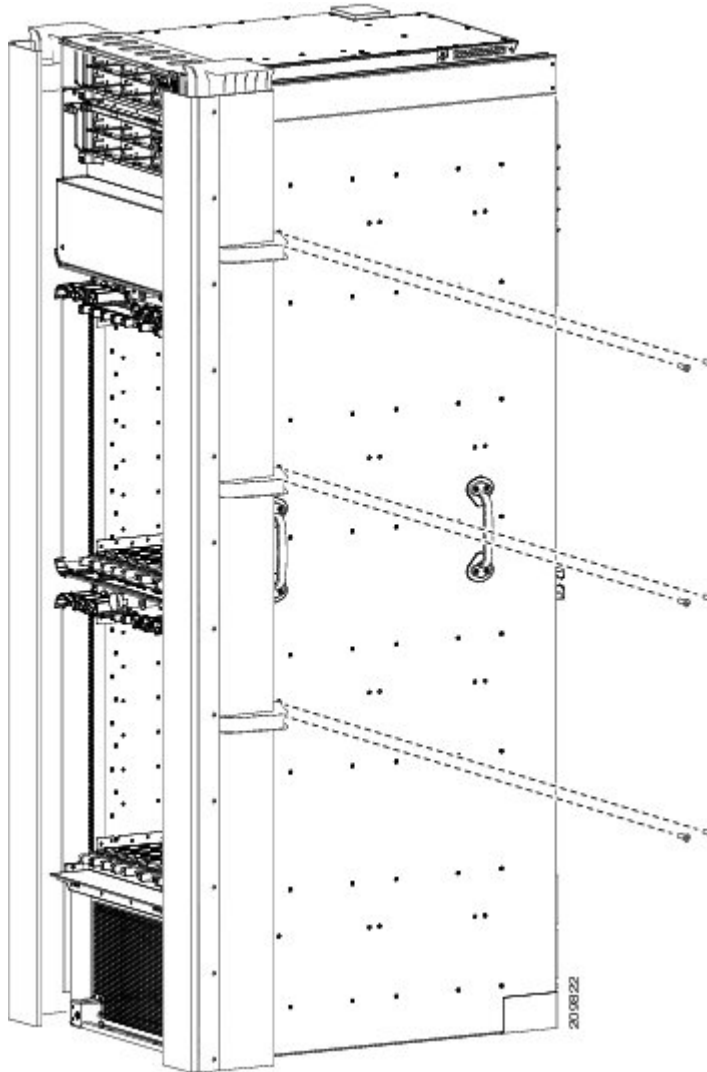


- d) Insert the twelve M8x12 screws that attach the three brackets (two screws on each bracket) on each trough to the side of the chassis. Use the screwdriver to turn the screws clockwise to attach the cable trough brackets firmly to the side of the chassis. See the below figure.



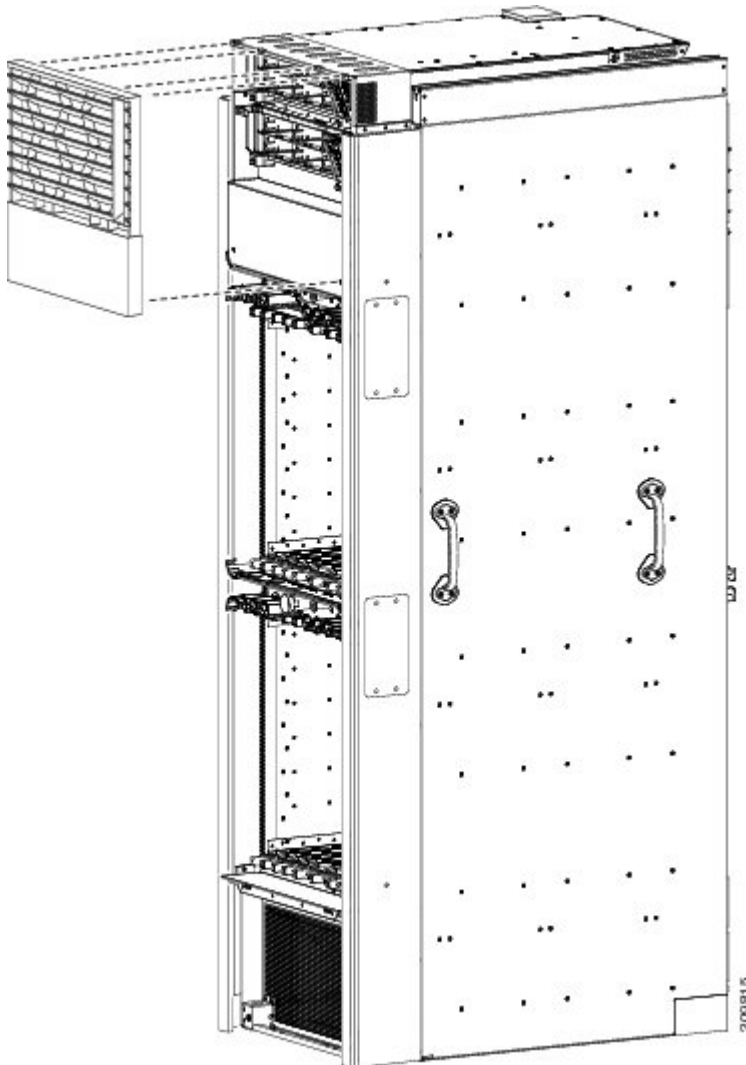
**Note** The brackets for securing the wide cable trough to the side of the chassis are shipped pre-installed on the cable trough.

**Figure 53: Attaching Wide Vertical Cable Trough Brackets to Side of Chassis**



- Step 7** (Installing the Upper Grille) Attach the upper grille by carefully inserting the four tabs on the grille into the appropriate hook hanger brackets on the top of the upper grille support (see below figure).
- Step 8** Press the grille and bezel firmly against the chassis until it snaps onto the ball stud snaps.

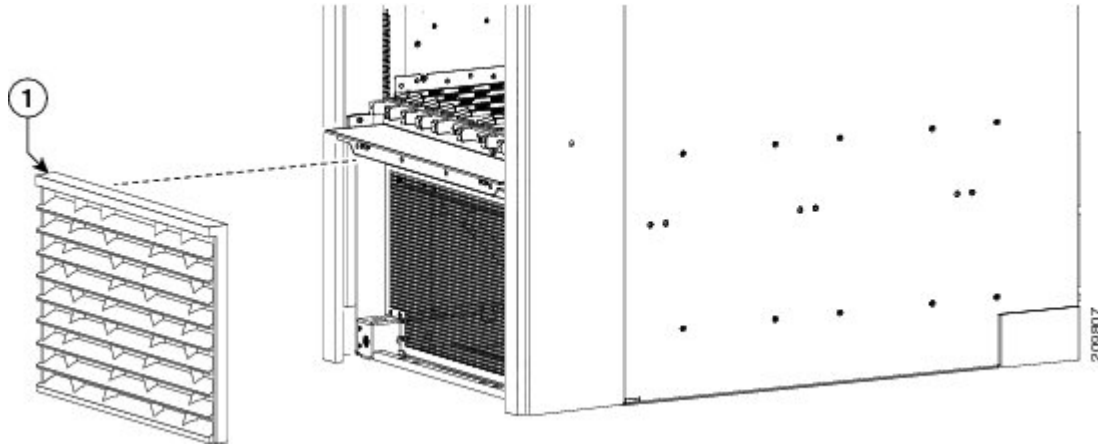
**Figure 54: Attaching the Front Upper Grille**



**Step 9** (Attaching the Lower Grille) Attach the lower grille by carefully inserting the tabs on the grille into the brackets on the bottom of the inlet grille frame.

**Step 10** Press the lower grille firmly until it snaps onto the ball stud snaps.

**Figure 55: Installing the Front Lower Grille**



1	Front lower grille
---	--------------------

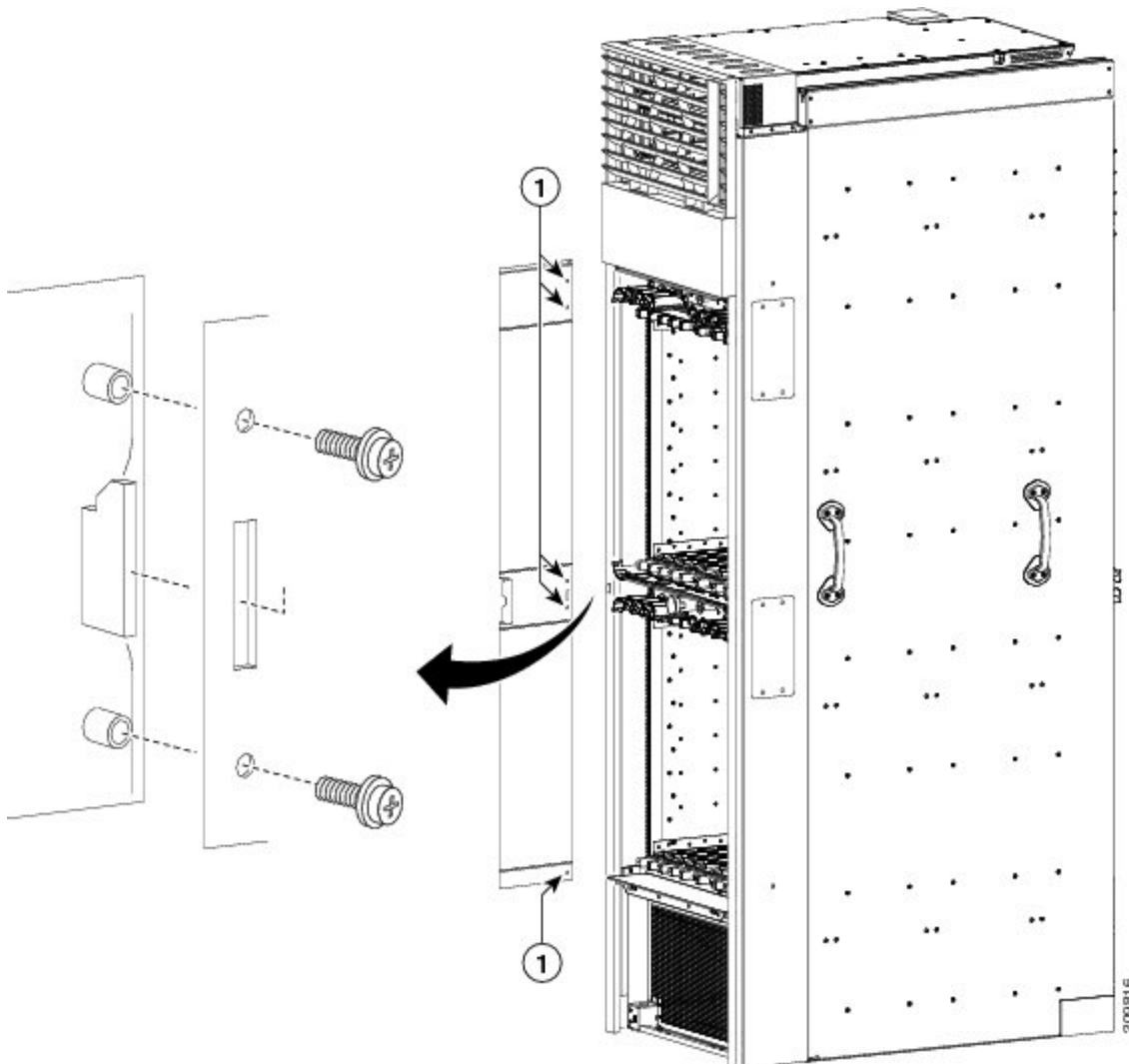
**Note** The procedure for installing the front doors on the default vertical cable troughs and the wide cable troughs is the same.

**Step 11** (Attaching the Front Exterior Doors) Orient the doors so that the slot on the metal part in the middle of the doors is lined up with the tab on the vertical cable trough. The door will then drop into position. See the below figure.

**Note** The part number for the right door is 800-35628-xx; the part number for the left door is 800-35646-xx. The door lock is on the left door.

**Caution** The doors scratch easily, so they should be handled with care.

**Figure 56: Attaching the Front Doors**



1

Screw locations

**Step 12** Insert the screws into the appropriate screw holes in the doors, and use the screwdriver to tighten fully. There are 11 M4x8 screws on each side for the metal sections of the doors and six M4x8 screws on each side for the plexiglass section of the door.

**Note** To ensure that the door is well supported during installation, insert screws in the upper and lower metal sections first.

**Step 13** Ensure that the doors are properly aligned.  
The following substeps apply to the default cosmetics.

**Note** Typically, the doors will close without interfering with each other. However, you may need to adjust either the left or right door, or both, to align the doors properly. Adjust doors only if necessary.

- a) Check to see if the doors close without interfering with each other.
- b) To decrease the door gap, loosen the screws that secure the vertical trough to the chassis. Using the 2 mm hex key wrench, tighten the bottom set screws one full turn. Snug the screws that attach the vertical trough to the chassis and check the door alignment.
- c) To increase the door gap, loosen the screws that secure the vertical trough to the chassis. Using the 2 mm hex key wrench, tighten the top set screws one full turn. Snug the screws that attach the vertical trough to the chassis and check the door alignment.
- d) Repeat the procedure as necessary until the doors are properly aligned.
- e) Tighten the screws that secure the vertical trough to the chassis.

#### Step 14

For wide duct installations (see *Door Adjustments for Wide Trough Installation* figure below):

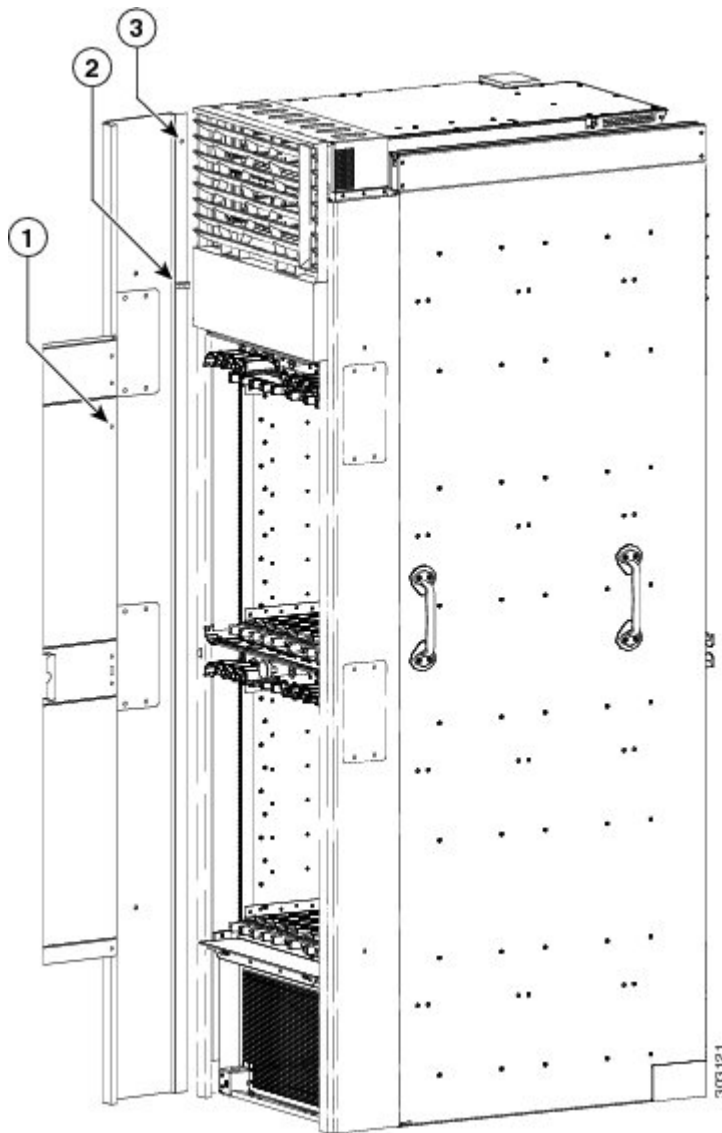
- a) Ensure that the doors are properly aligned.

**Note** Typically, the doors will close without interfering with each other. However, you may need to adjust either the left or right door, or both, to align the doors properly. Adjust doors only if necessary.

- b) Check to see if the doors close without interfering with each other.
- c) (Minor adjustments) Increase or decrease the door gap by loosening and adjusting the eleven (11) screws on each door as needed.
- d) (Major adjustments) Increase or decrease the door gap by loosening the seven (7) screws on the vertical metal bar on each door as needed.
- e) (Major adjustment) Using a flat blade screwdriver, insert it in the adjustment bracket (upper and lower) and pry either left or right to increase or decrease the door gap (see *Door Adjustments for Wide Trough Installation* figure below).
- f) Tighten all screws that were loosened during the procedure.

- g) Repeat procedure if additional adjustments are needed.

**Figure 57: Door Adjustments for Wide Trough Installation**



1	Minor adjustments (11 screws)	3	Major adjustments (7 screws on the vertical metal bar on each door)
2	Screwdriver location		

## Installing the Rear (MSC) Side Cosmetic Components

This section describes how to install the rear (MSC) side exterior cosmetic components on the Cisco CRS Series enhanced 16-slot line card chassis. While it is possible to install the various exterior components on the chassis in a different order, it is easier to install them in the order outlined in this section. [Figure 49: Rear \(MSC\) Side Exterior Cosmetic Components, on page 85](#) shows the exterior cosmetics for the rear (MSC) side of a Cisco CRS Series enhanced 16-slot line card chassis.

The midchassis cable management bracket and rear door strike tube are shipped pre-installed on the chassis.

This section contains the following procedures:

**Note**

---

For instructions on installing the rear cosmetics if the vertical trough is not used, see [Attaching the Upper Rear Air Grille and Rear Kick Plate Without Vertical Troughs, on page 104](#)

---

### Prerequisites

Before performing these tasks, you must first unpack and secure the chassis. See *Cisco CRS Carrier Routing System 16-Slot Line Card Chassis Unpacking, Moving, and Securing Guide*.

### Required Tools and Equipment

You need the following tools and parts to perform this task:

- 8-in. long number 1 Phillips screwdriver—magnetic head preferable #1
- Rear vertical cable troughs (included in CRS-16-REAR-CM)
- Rear kick plate (included in CRS-16-REAR-CM)
- Upper air grille (CRS-16-REAR-GRL)
- Rear doors (CRS-16-DOORS-R)
- Upper rear air grille with mounting brackets (CRS-16-REAR-GRL), only if vertical troughs are not used
- Rear kick plate with mounting brackets (CRS-16-KP-REAR), only if vertical troughs are not used

### Steps

To install the rear (MSC) exterior cosmetic components, perform the following steps:

## SUMMARY STEPS

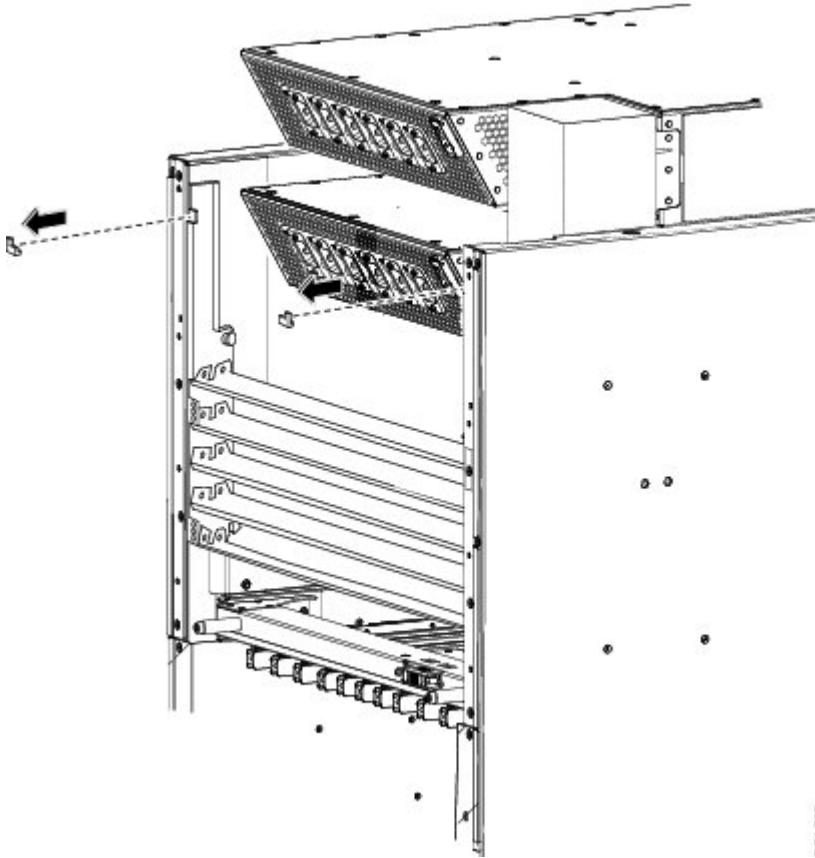
1. Unpack all cosmetic parts to prepare for installation.
2. (Attaching the Rear Vertical Cable Troughs) Before you attach the left and right vertical cable troughs, if the verticals have L-brackets, they will need to be removed so that they do not interfere with the air deflector. See below figure.
3. Attach the rear vertical cable troughs—one left and one right—to the rear of the chassis (see the figure below) by inserting the 10 M4x14-mm pan head screws (five on each side) and using the screwdriver to turn the screws clockwise to attach the cable troughs firmly to the chassis. (You might need to use a ladder to reach the upper screws.)
4. (Attaching the Upper Rear Air Grille) Follow these steps if you are using the vertical troughs. To install the upper rear air grille without the vertical troughs, see the [Attaching the Upper Rear Air Grille and Rear Kick Plate Without Vertical Troughs](#), on page 104. Attach the upper grille by carefully hooking the hanger brackets that are on top of the grille over the hook supports that are on top of the vertical cable troughs (see below figure).
5. Press the upper rear air grille firmly until its ball studs snap onto the ball stud retainers.
6. (Attaching the Rear Kick Plate) Carefully slot the tabs on the bottom of the rear kick plate into the brackets on the chassis (see below figure).
7. To secure the top fasteners, firmly press the top edge of the rear kick plate against the chassis until it snaps onto the ball stud snaps.
8. (Installing the Rear Doors) Orient the doors so that the slot on the metal part in the middle of the doors is lined up with the tab on the vertical cable trough. The door will then drop into position. See figure below.
9. Insert the screws into the appropriate screw holes in the doors, and use the screwdriver to tighten fully. There are 10 M4x8 screws on each side for the metal sections of the doors and six M4x8 screws on each side for the plexiglass section of the door.
10. Ensure that the doors are properly aligned.



**DETAILED STEPS**

- Step 1** Unpack all cosmetic parts to prepare for installation.
- Step 2** (Attaching the Rear Vertical Cable Troughs) Before you attach the left and right vertical cable troughs, if the verticals have L-brackets, they will need to be removed so that they do not interfere with the air deflector. See below figure.

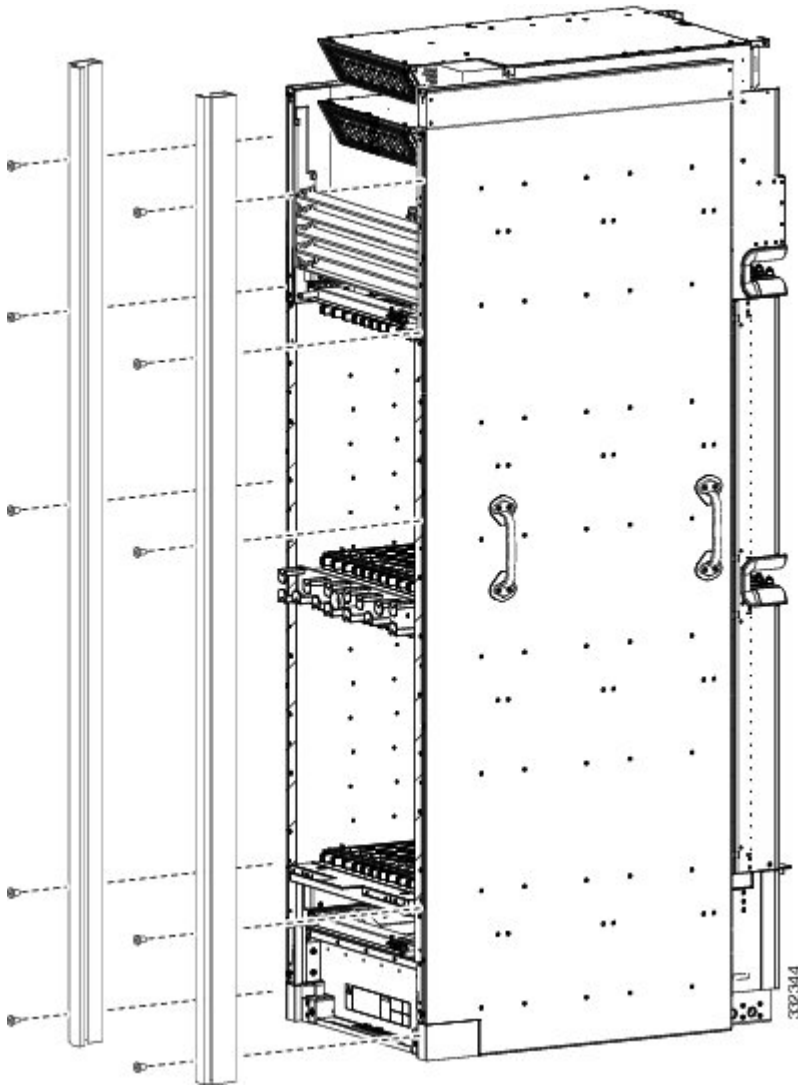
**Figure 58: Removing L-Brackets**



- Step 3** Attach the rear vertical cable troughs—one left and one right—to the rear of the chassis (see the figure below) by inserting the 10 M4x14-mm pan head screws (five on each side) and using the screwdriver to turn the screws clockwise to attach the cable troughs firmly to the chassis. (You might need to use a ladder to reach the upper screws.)

**Note** We recommend that you use two people to install the troughs, one person to hold the troughs in place while the other person inserts and tightens the screws.

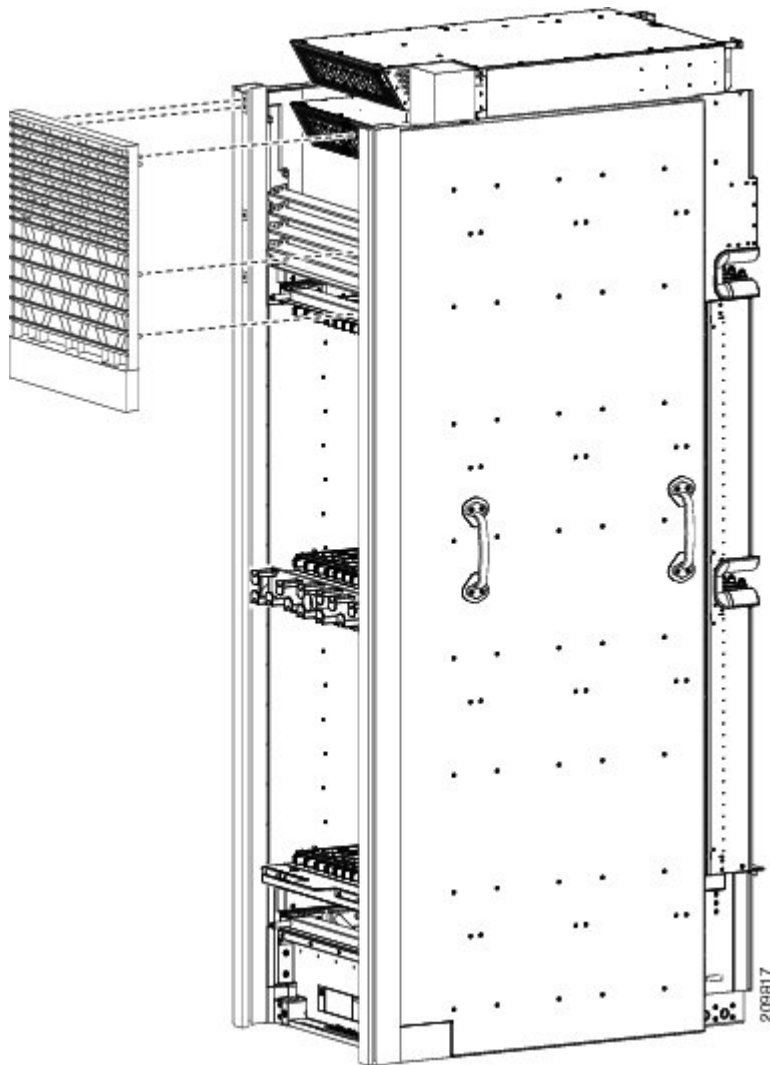
**Figure 59: Attaching the Rear (MSC) Side Vertical Cable Troughs**



**Step 4** (Attaching the Upper Rear Air Grille) Follow these steps if you are using the vertical troughs. To install the upper rear air grille without the vertical troughs, see the [Attaching the Upper Rear Air Grille and Rear Kick Plate Without Vertical Troughs, on page 104](#). Attach the upper grille by carefully hooking the hanger brackets that are on top of the grille over the hook supports that are on top of the vertical cable troughs (see below figure).

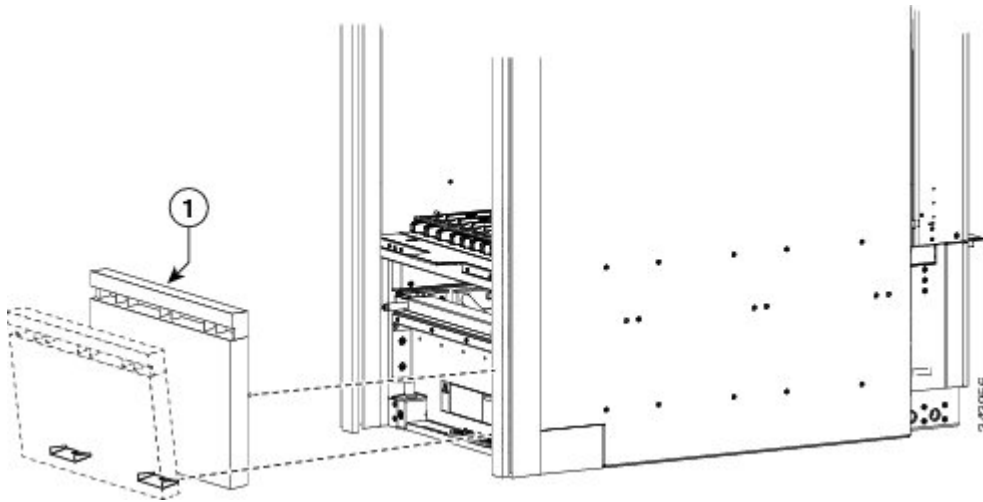
**Note** Because the upper rear air grille must be installed at the top of the chassis, it is easier to stand on a ladder while installing it.

**Note** Ensure cables are dressed correctly to ensure enough clearance to install the upper air grille.



- Step 5** Press the upper rear air grille firmly until its ball studs snap onto the ball stud retainers.
- Step 6** (Attaching the Rear Kick Plate) Carefully slot the tabs on the bottom of the rear kick plate into the brackets on the chassis (see below figure).

**Figure 60: Attaching the Rear Kick Plate**

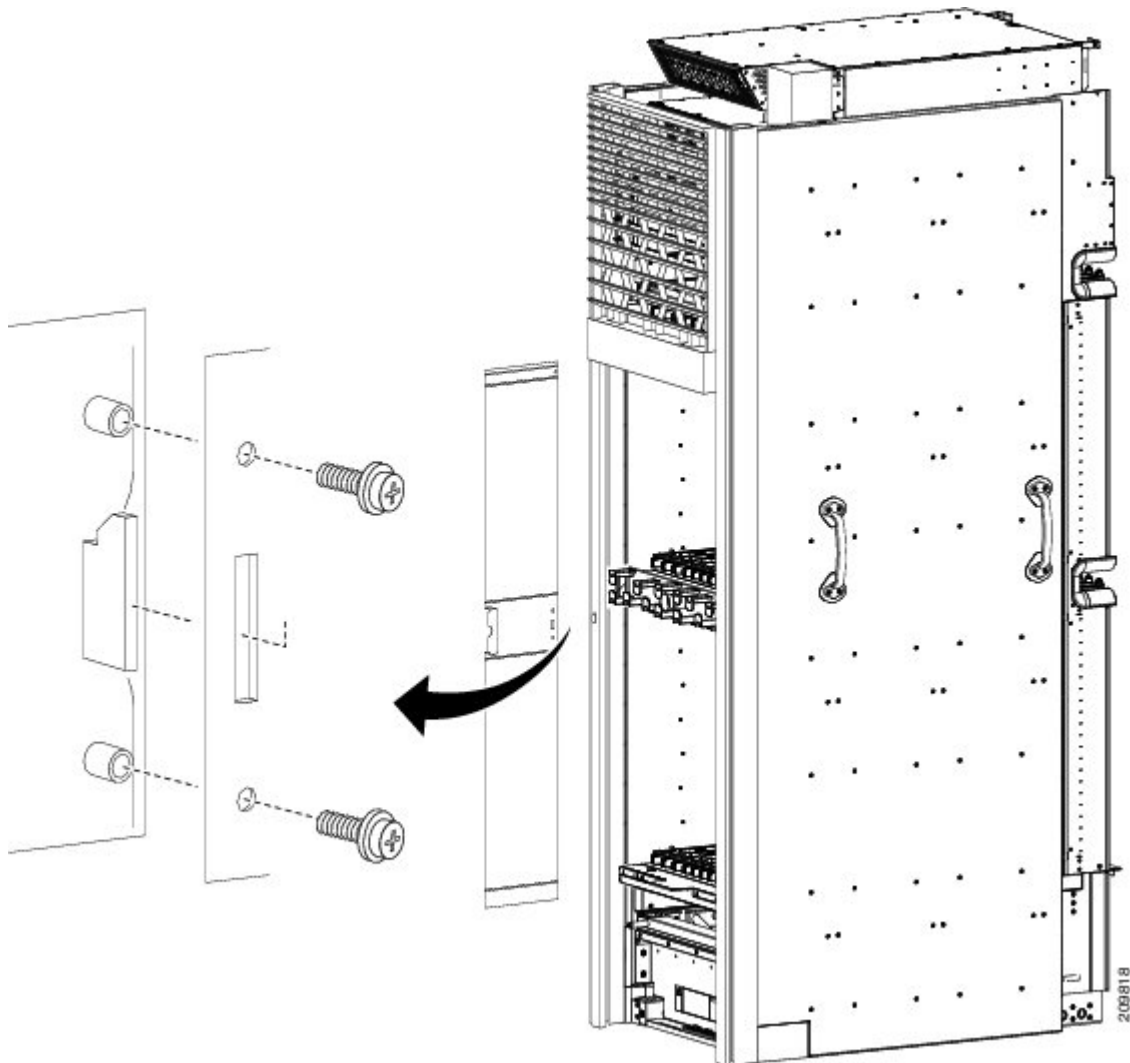


1	Rear kick plate
---	-----------------

- Step 7** To secure the top fasteners, firmly press the top edge of the rear kick plate against the chassis until it snaps onto the ball stud snaps.
- Step 8** (Installing the Rear Doors) Orient the doors so that the slot on the metal part in the middle of the doors is lined up with the tab on the vertical cable trough. The door will then drop into position. See figure below.
- Note** The part number for the right door is 800-35638-xx; the part number for the left door is 800-35475-xx. The door lock is on the left door.

**Caution** The doors scratch easily, so they should be handled with care.

**Figure 61: Attaching the Rear Doors**



- Step 9** Insert the screws into the appropriate screw holes in the doors, and use the screwdriver to tighten fully. There are 10 M4x8 screws on each side for the metal sections of the doors and six M4x8 screws on each side for the plexiglass section of the door.
- Note** To ensure that the door is well supported during installation, insert screws in the upper and lower metal sections first.
- Step 10** Ensure that the doors are properly aligned.
- Note** Typically, the doors will close without interfering with each other. However, you may need to adjust either the left or right door, or both, to align the doors properly. Adjust doors only if necessary.
- a) Check to see if the doors close without interfering with each other.

- b) To decrease the door gap, loosen the screws that secure the vertical trough to the chassis. Using the 2 mm hex key wrench, tighten the bottom set screws one full turn. Snug the screws that attach the vertical trough to the chassis and check the door alignment.
- c) To increase the door gap, loosen the screws that secure the vertical trough to the chassis. Using the 2 mm hex key wrench, tighten the top set screws one full turn. Snug the screws that attach the vertical trough to the chassis and check the door alignment.
- d) Repeat the procedure as necessary until the doors are properly aligned.
- e) Tighten the screws that secure the vertical trough to the chassis.

## Attaching the Upper Rear Air Grille and Rear Kick Plate Without Vertical Troughs

Use the procedures in this section to install the upper rear air grille (CRS-16-REAR-GRL) and rear kick plate (CRS-16-KP-REAR) if you are not using the vertical troughs. If you are using the vertical troughs, see the procedure in the [Installing the Rear \(MSC\) Side Cosmetic Components](#), on page 97.


**Note**

Because the upper rear air grille must be installed at the top of the chassis, it is easier to stand on a ladder while installing it.


**Note**

Ensure cables are dressed correctly to ensure enough clearance to install the upper air grille.

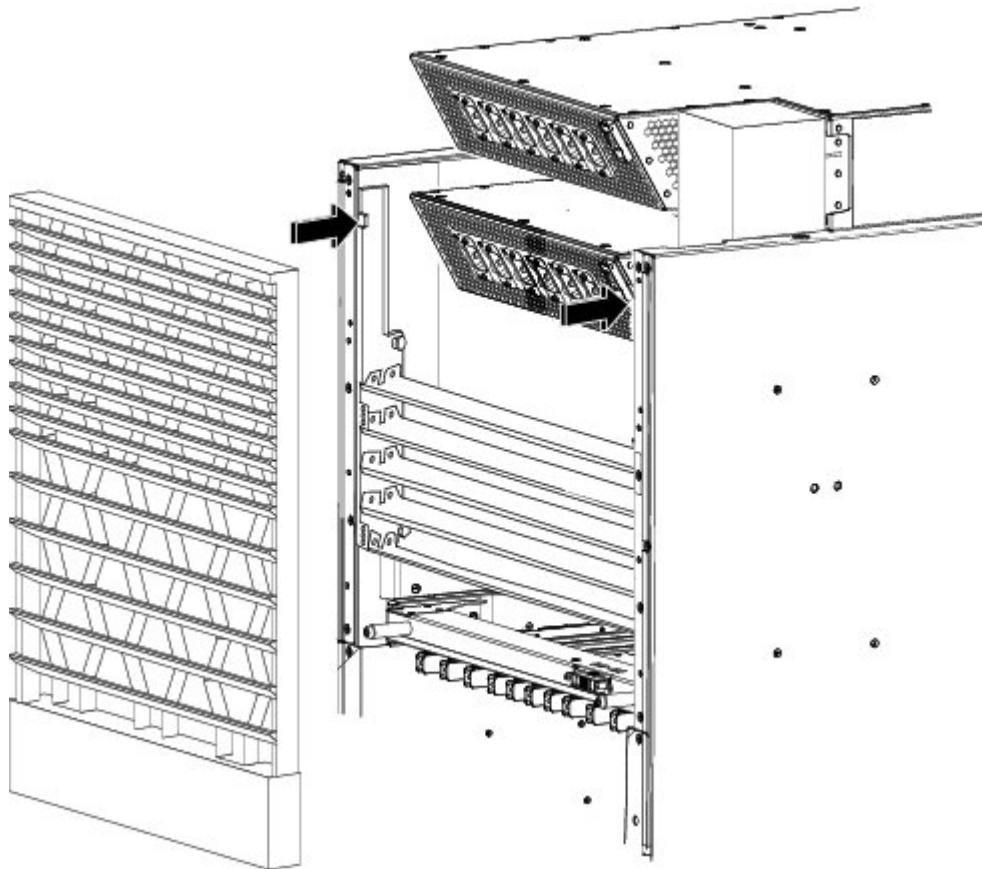
### SUMMARY STEPS

1. To attach the upper rear air grille, hang the grille on the inside grille supports.
2. Pivot to the closed position.
3. To attach the rear kick plate, first attach the two brackets provided with the kick plate and fasten them using the captive screws that are included (see figure below).
4. Carefully slot the tabs on the bottom of the rear kick plate into the brackets on the chassis (see figure below).
5. To secure the top fasteners, firmly press the top edge of the rear kick plate against the chassis until it snaps onto the ball stud snaps.

## DETAILED STEPS

**Step 1** To attach the upper rear air grille, hang the grille on the inside grille supports.

*Figure 62: Grille Positioning and Inside Supports*

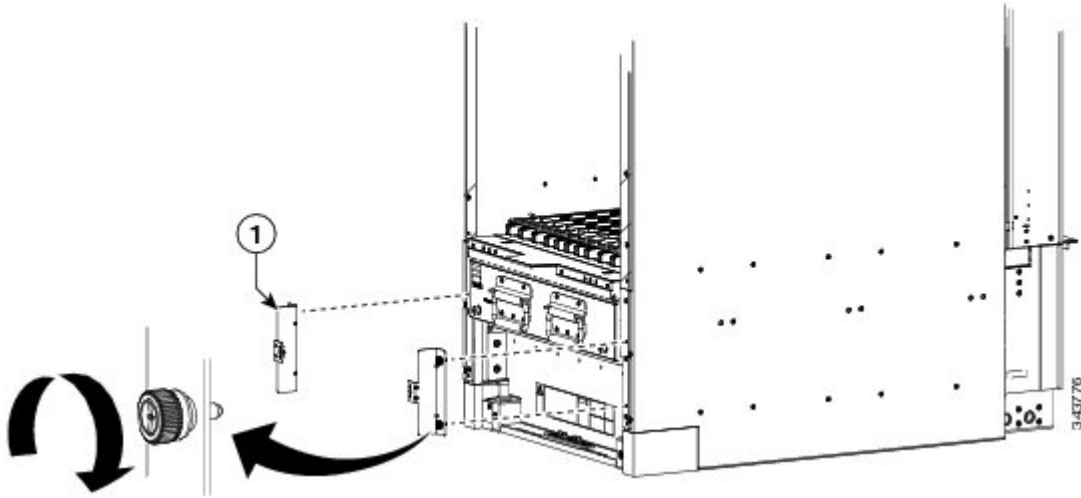


5101603

**Step 2** Pivot to the closed position.

**Step 3** To attach the rear kick plate, first attach the two brackets provided with the kick plate and fasten them using the captive screws that are included (see figure below).

**Figure 63: Attaching Brackets for the Rear Kick Plate**

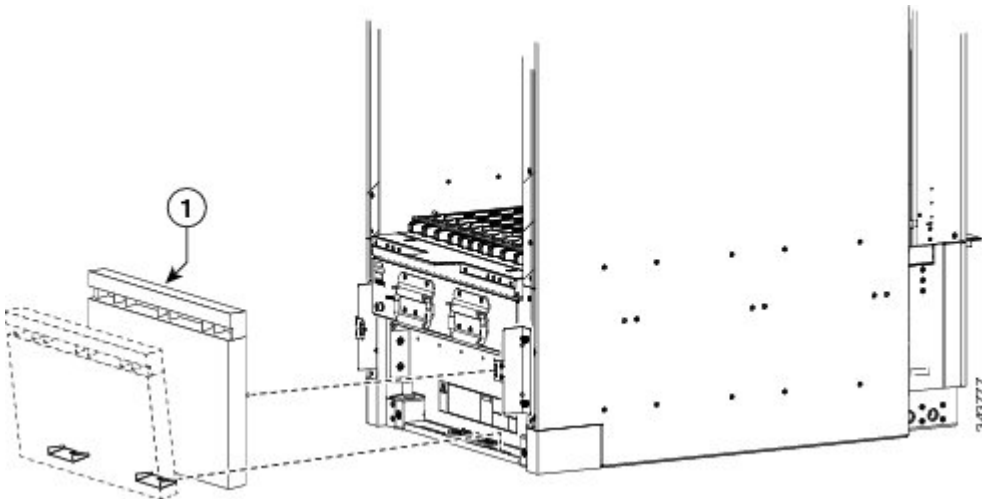


1

Brackets for rear kick plate

**Step 4** Carefully slot the tabs on the bottom of the rear kick plate into the brackets on the chassis (see figure below).

**Figure 64: Attaching the Lower Rear Kick Plate**



1

Rear kick plate



**Step 5** To secure the top fasteners, firmly press the top edge of the rear kick plate against the chassis until it snaps onto the ball stud snaps.

---





## Installing Line Cards, PLIMs, and Associated Components

---

This chapter provides instructions on how to install the Cisco CRS Enhanced 16-Slot Line Card Chassis (LCC) cards, physical layer interface modules (PLIMs), and any associated components.

This chapter presents the following topics:

- [About Installing and Removing Cards and Associated Components, page 109](#)
- [Installing or Removing a Slot Cover, page 118](#)
- [Installing or Removing an Impedance Carrier, page 122](#)
- [Installing an RP, PRP, or DRP Card, page 126](#)
- [Installing a Fan Controller Card, page 140](#)
- [Installing a Switch Fabric Card, page 145](#)
- [Installing a Line Card, page 152](#)
- [Installing a PLIM, page 161](#)
- [Installing a Card-Based Hard Drive, page 167](#)
- [Installing a PCMCIA Card, page 168](#)
- [Installing Optical Modules, page 170](#)
- [Installing a Cable Management Bracket, page 171](#)

### About Installing and Removing Cards and Associated Components

This section contains some general information about installing and removing cards, PLIMs, and associated components.

## Guidelines for Card Installation and Removal

Guidelines for card installation and removal include the following:

- Online (in-service) insertion and removal (OIR) is supported, enabling you to remove and install cards while the router is operating. OIR is seamless to users on the network, maintains all routing information, and ensures session preservation. You do not need to notify the software or reset the power. You have the option of using the Cisco IOS XR **shutdown** command before removing a card.



---

**Note**

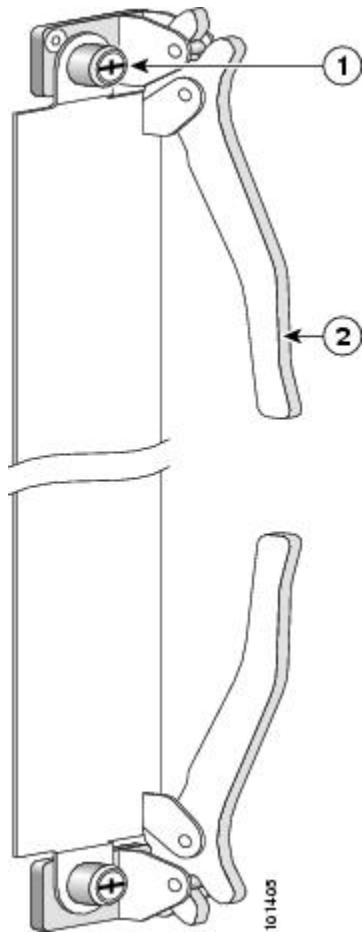
OIR removes power to a specific slot before the switch fabric card is replaced. The power remains on for all other slots.

---

- The different cards and PLIMs in the Cisco CRS Series Enhanced 16-Slot Line Card Chassis are all attached to the chassis itself using a pair of ejector levers and captive screws. The two ejector levers release the card or PLIM from its midplane connector. The exact locations of the ejector levers and captive screws vary slightly from card to card, but are, in general, in the same locations: on the upper

and bottom ends of the faceplate of the card. This figure shows the locations of the ejector levers and captive screws (on a modular services card [MSC]).

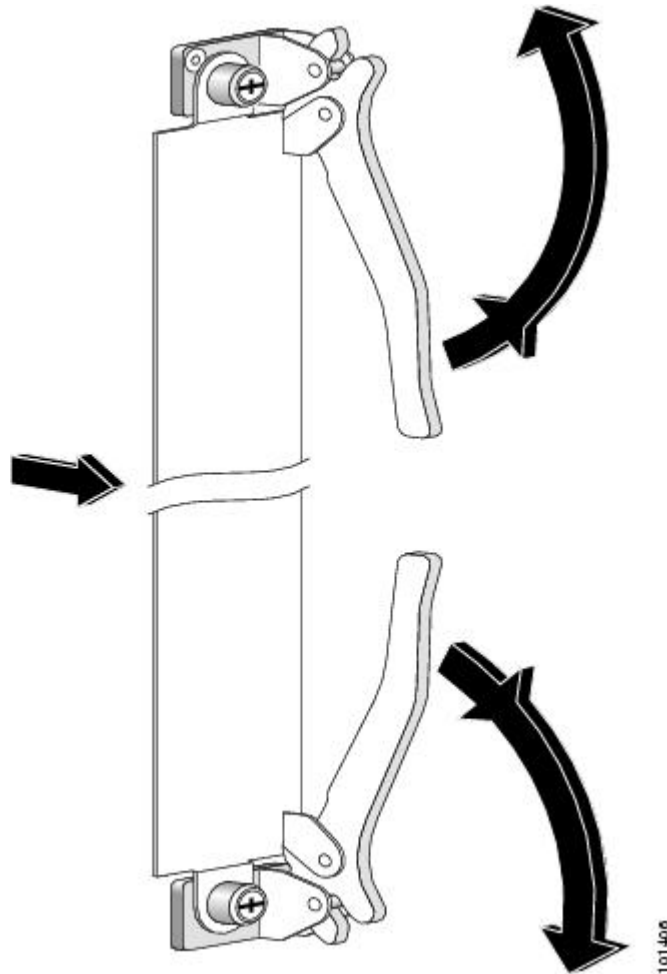
**Figure 65: Ejector Levers and Captive Screws**



1	Captive screw	2	Ejector lever
---	---------------	---	---------------

This figure shows how to operate the ejector levers. Be sure to operate both levers simultaneously.

**Figure 66: Operating Ejector Levers**



**Caution**

When you remove a card, always use the ejector levers to ensure that the connector pins disconnect from the midplane in the sequence expected by the router.

- You should install the cards in the following order during the chassis initial installation process:
  - Always install cards in the empty slots first from one side to the other. The chassis is shipped with all slots either containing impedance carriers or covered by slot covers to help maintain chassis stiffness and ensure that the chassis is undamaged during shipment. See the [About Impedance Carriers and Slot Covers](#), on page 113.
  - Install the route processor (RP) cards first, the left one before the right one. Tighten the screws only after fully inserting both RP cards.
  - Install the Cisco CRS Series Enhanced 16-Slot Line Card Chassis fan controller cards in the same manner.

- Install the switch fabric cards in the same manner, one shelf at a time.
- For an MSC, FP, or LSP line card or a PLIM, remove one impedance carrier, install a functional board and tighten the screw, and then repeat the process until all line cards and PLIMs have been installed.

For information about the slot numbers, see the [Slot Numbers, on page 8](#) section.

**Caution**

---

The router may indicate a hardware failure if you do not follow proper procedures. Remove or install only one card at a time. Allow at least 15 seconds for the router to complete the preceding tasks before removing or installing another card.

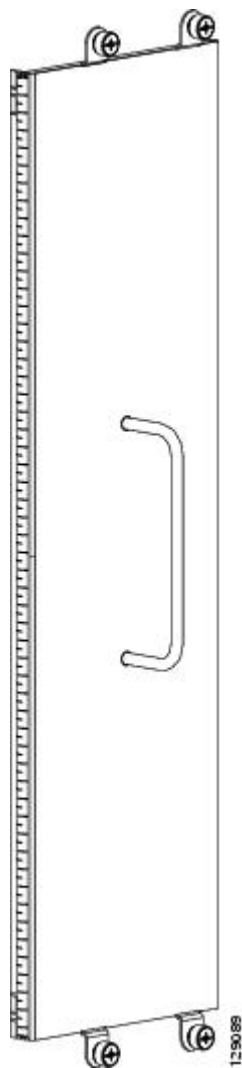
---

## About Impedance Carriers and Slot Covers

When shipped, some slots in the chassis may contain impedance carriers or are covered by slot covers to help ensure that the chassis is undamaged during shipment. Four different types of impedance carriers and slot covers exist for the four different sizes of slots in the chassis (see below figures).

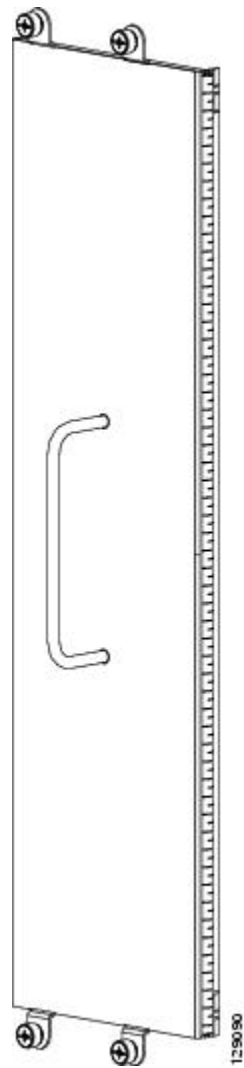
For further information on installing and removing the slot covers and impedance carriers, see the [Installing a Slot Cover](#), on page 119, the [Removing a Slot Cover](#), on page 121, the [Installing an Impedance Carrier](#), on page 122, and the [Removing an Impedance Carrier](#), on page 125.

**Figure 67: RP Slot Cover**

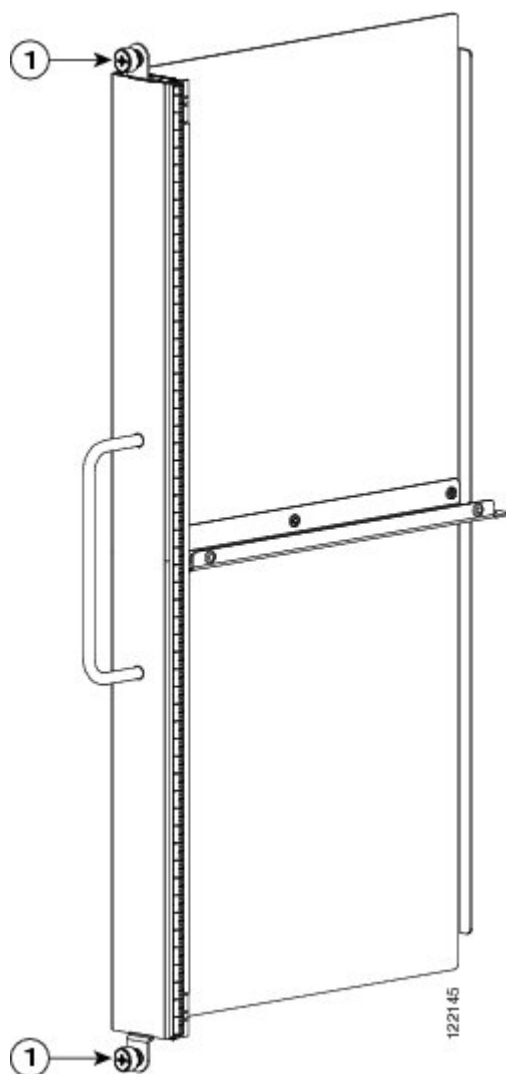


**Figure 68: Switch Fabric Slot Cover**

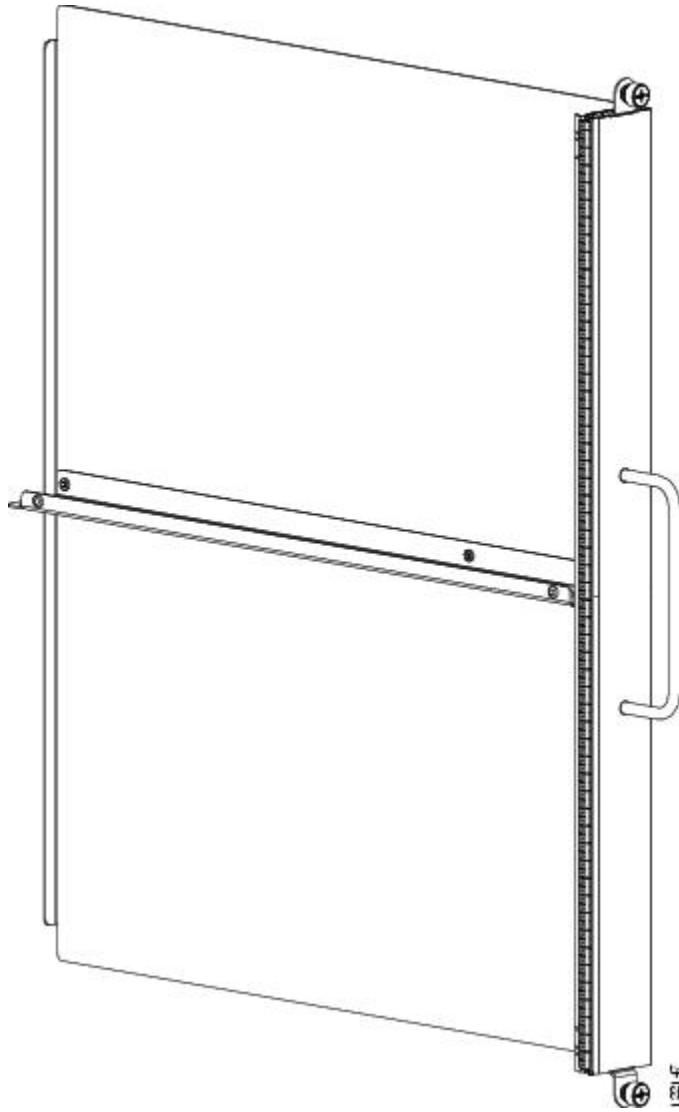




**Figure 69: PLIM Slot Impedance Carrier**



*Figure 70: MSC Slot Impedance Carrier*



## About Hard Drives and PCMCIA Cards

Both replacement and additional optional hard drives and PCMCIA cards are available for both the RP and DRP cards.

The hard drive is an IDE hard drive used for gathering debugging information, such as core dumps from the RPs, DRPs, or line cards. The IDE hard drive is typically powered down and activated only when there is a need to store data. The drive is not vital to a functioning Cisco CRS Series Enhanced 16-Slot Line Card Chassis and is optional.

**Note**

Only the original route processor (RP) card uses a PCMCIA card. The performance route processor (PRP) card has a USB connector for using a flash drive.

**Note**

Core dumps are discoverable only through intervention with the Cisco CRS Series Enhanced 16-Slot Line Card Chassis system software.

Physically, the RP or DRP hard drive is a hot-pluggable PC board and sled-mounted drive with a connector interface that gets cleanly seated into a route processor card. In general, removal and replacement of this drive is not required.

The RP and DRP cards provide two PCMCIA flash slots, each card providing up to 1 GB of flash storage. One PCMCIA flash subsystem is accessible externally, is removable, and allows you to transfer images and configurations by plugging in a PCMCIA flash card. The other subsystem is fixed to the RP or DRP, not removable, and for permanent storage of configurations and images.

## About Cable Management Brackets

The chassis includes a cable management system that organizes the interface cables entering and exiting the different cards, keeping them out of the way and free of sharp bends.

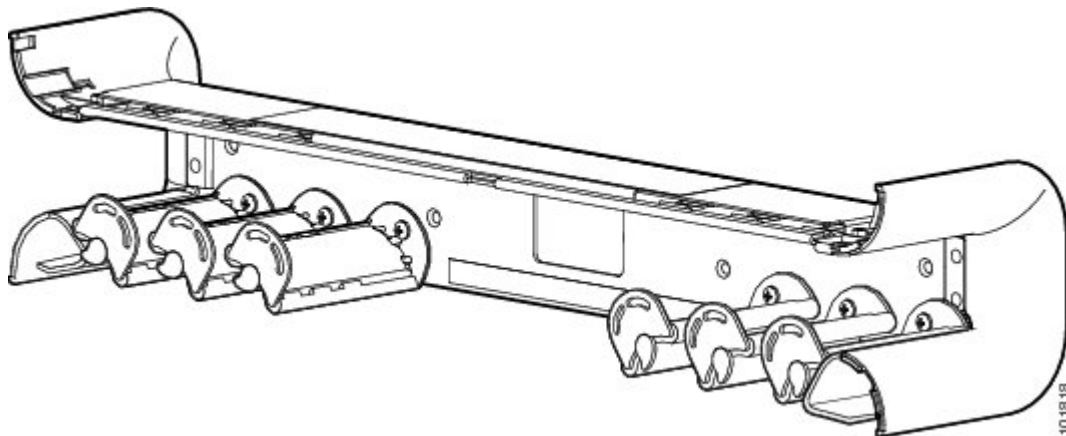
**Caution**

Excessive bending of interface cables can cause damage to the cables.

The Cisco CRS Series Enhanced 16-Slot Line Card Chassis arrives with a midchassis and upper-chassis horizontal cable management bracket preinstalled on the front (PLIM) side of the chassis.

This figure shows the midchassis cable management bracket.

**Figure 71: Midchassis Cable Management Bracket (Front [PLIM] Side of Chassis Only)**



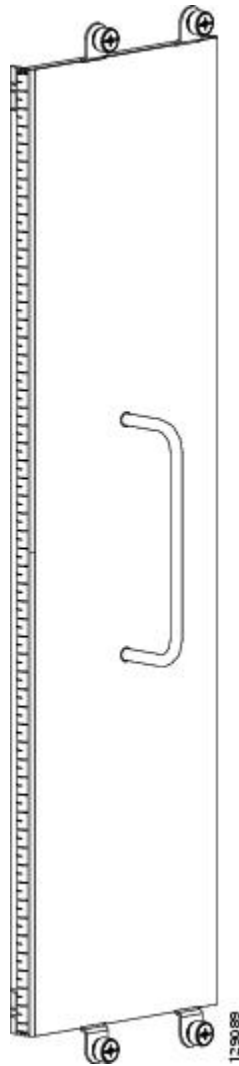
## Installing or Removing a Slot Cover

This section contains the following procedures:

## Installing a Slot Cover

This section describes how to install a slot cover in the Cisco CRS Series Enhanced 16-Slot Line Card Chassis. The chassis is shipped with slot covers over the switch fabric card and RP card slots; we advise installing slot covers over any empty slots in the chassis. Both slot cover types are installed in the same manner. The figure below shows an RP slot cover for reference. For more detailed information on the slot covers, see the [About Impedance Carriers and Slot Covers](#), on page 113.

**Figure 72: RP Slot Cover**



### Prerequisites

Before performing this task, open the cosmetic doors, if installed, and ensure that the slot over which you are about to install the cover is empty. See the [About Impedance Carriers and Slot Covers](#), on page 113 and the [Removing a Switch Fabric Card](#), on page 173.

## Required Tools and Equipment

You need the following tools and part to perform this task:

- ESD-preventive wrist strap
- Number 2 Phillips screwdriver or number 2 common (flat head) screwdriver
- Slot cover

## Steps

To install a slot cover, perform the following steps:

### SUMMARY STEPS

1. Attach the ESD-preventive wrist strap to your wrist and connect its leash to one of the ESD connection sockets: on the front (PLIM) side of the chassis there is one ESD connection socket right above the fan controllers. On the rear (MSC) side of the chassis there are two ESD connection sockets right above the cable management tray in the center of the chassis (left and right). You can also connect the ESD-preventive wrist strap leash to any bare metal surface on the chassis.
2. Using the handle, hold the slot cover in place over the slot.
3. Partially tighten each of the four captive screws on the front panel of the slot cover (either by hand or with the number 2 Phillips screwdriver or number 2 common (flat head) screwdriver) to make sure that they are all engaged.
4. Use the number 2 Phillips screwdriver or number 2 common (flat head) screwdriver to fully tighten the captive screws to seat the slot cover firmly in place.

### DETAILED STEPS

- 
- |               |   |
|---------------|---|
| <b>Step 1</b> | Attach the ESD-preventive wrist strap to your wrist and connect its leash to one of the ESD connection sockets: on the front (PLIM) side of the chassis there is one ESD connection socket right above the fan controllers. On the rear (MSC) side of the chassis there are two ESD connection sockets right above the cable management tray in the center of the chassis (left and right). You can also connect the ESD-preventive wrist strap leash to any bare metal surface on the chassis. |
| <b>Step 2</b> | Using the handle, hold the slot cover in place over the slot.   |
| <b>Step 3</b> | Partially tighten each of the four captive screws on the front panel of the slot cover (either by hand or with the number 2 Phillips screwdriver or number 2 common (flat head) screwdriver) to make sure that they are all engaged.  |
| <b>Step 4</b> | Use the number 2 Phillips screwdriver or number 2 common (flat head) screwdriver to fully tighten the captive screws to seat the slot cover firmly in place.  |
- 

## What to Do Next

After performing this task, close the front (PLIM) side cosmetic doors, if installed.

## Removing a Slot Cover

This section describes how to remove a slot cover from the Cisco CRS Series Enhanced 16-Slot Line Card Chassis. The chassis may be shipped with slot covers over the switch fabric card and RP card slots. Both slot cover types are removed in the same manner. [Figure 72: RP Slot Cover, on page 119](#) shows an RP slot cover for reference. For more detailed information on the slot covers, see the [About Impedance Carriers and Slot Covers, on page 113](#).

### Prerequisites

Before performing this task, open the front (PLIM) side cosmetic doors, if installed.

### Required Tools and Equipment

You need the following tools to perform this task:

- ESD-preventive wrist strap
- Number 2 Phillips screwdriver or number 2 common (flat head) screwdriver

### Steps

To remove a slot cover, perform the following steps:

#### SUMMARY STEPS

1. Attach the ESD-preventive wrist strap to your wrist and connect its leash to one of the ESD connection sockets: on the front (PLIM) side of the chassis there is one ESD connection socket right above the fan controllers. On the rear (MSC) side of the chassis there are two ESD connection sockets right above the cable management tray in the center of the chassis (left and right). You can also connect the ESD-preventive wrist strap leash to any bare metal surface on the chassis.
2. Grasp the slot cover with one hand.
3. Use the number 2 Phillips screwdriver or number 2 common (flat head) screwdriver to loosen the four captive screws that attach the slot cover to the chassis.
4. Holding the slot cover by the handle, remove it, and set it carefully aside.

#### DETAILED STEPS

##### Step 1

Attach the ESD-preventive wrist strap to your wrist and connect its leash to one of the ESD connection sockets: on the front (PLIM) side of the chassis there is one ESD connection socket right above the fan controllers. On the rear (MSC) side of the chassis there are two ESD connection sockets right above the cable management tray in the center of the

chassis (left and right). You can also connect the ESD-preventive wrist strap leash to any bare metal surface on the chassis.

- Step 2** Grasp the slot cover with one hand.
- Step 3** Use the number 2 Phillips screwdriver or number 2 common (flat head) screwdriver to loosen the four captive screws that attach the slot cover to the chassis.
- Step 4** Holding the slot cover by the handle, remove it, and set it carefully aside.
- 

## What to Do Next

After performing this task, store the slot cover for later reuse. You may now install a card in the uncovered slot. See the [Installing a Switch Fabric Card, on page 146](#) and the [Installing an RP, PRP, or DRP Card, on page 130](#) for further details.

# Installing or Removing an Impedance Carrier

This section contains the following procedures:

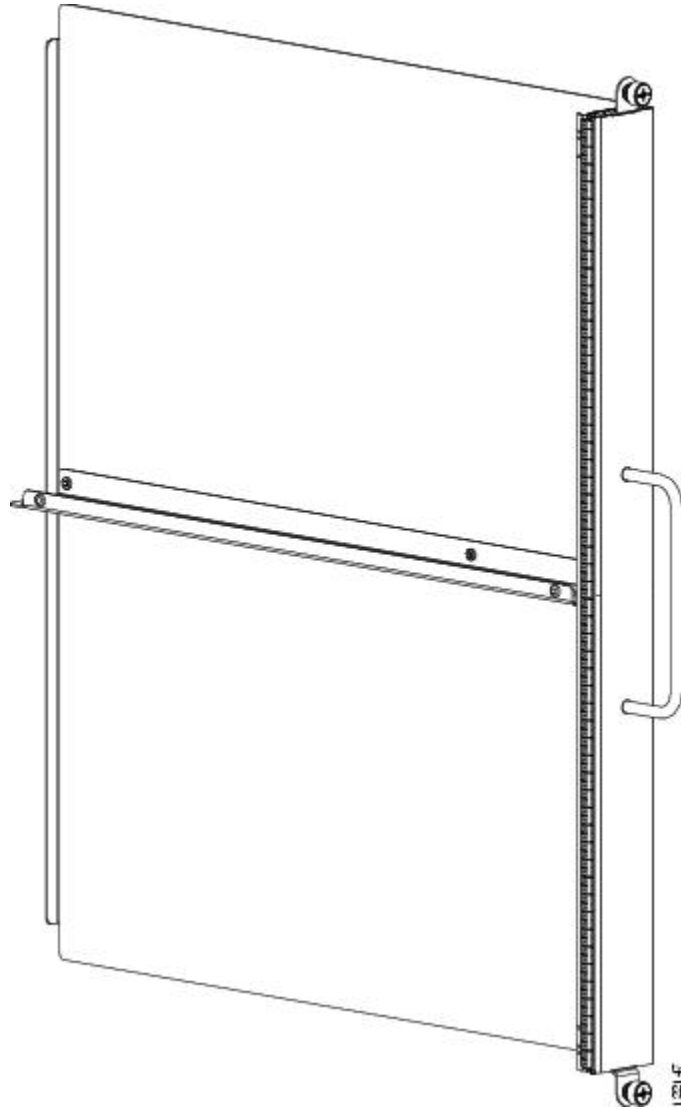
## Installing an Impedance Carrier

This section describes how to install an impedance carrier in the Cisco CRS Series Enhanced 16-Slot Line Card Chassis. The chassis is shipped with impedance carriers installed in the MSC and PLIM slots. Both types of impedance carrier are installed in the same manner. This figure shows an MSC impedance carrier for



reference. For more detailed information on impedance carriers, see the [About Impedance Carriers and Slot Covers](#), on page 113.

**Figure 73: MSC Slot Impedance Carrier**



## Prerequisites

Before performing this task, open the cosmetic doors, if installed, and ensure that the slot in which you are about to install the impedance carrier is empty. See the [About Impedance Carriers and Slot Covers](#), on page 113 and the [Removing an MSC, FP, or LSP Line Card](#), on page 178 or the [Removing a PLIM](#), on page 187 (depending on the slot in which you are installing an impedance carrier).

## Required Tools and Equipment

You need the following tools and part to perform this task:

- ESD-preventive wrist strap
- Number 2 Phillips screwdriver or number 2 common (flat head) screwdriver
- Impedance carrier:
  - MSC impedance carrier—Cisco Product number CRS-MSC-IMPEDANCE=

or

- ◦ PLIM impedance carrier—Cisco Product number CRS-INT-IMPEDANCE=

## Steps

To install an impedance carrier, perform the following steps:

### SUMMARY STEPS

1. Attach the ESD-preventive wrist strap to your wrist and connect its leash to one of the ESD connection sockets: on the front (PLIM) side of the chassis there is one ESD connection socket right above the fan controllers. On the rear (MSC) side of the chassis there are two ESD connection sockets right above the cable management tray in the center of the chassis (left and right). You can also connect the ESD-preventive wrist strap leash to any bare metal surface on the chassis.
2. Use both hands while inserting an impedance carrier. Use one hand on the faceplate and the other hand along the base of the impedance carrier to guide it into a slot.
3. Slide the impedance carrier into the chassis until the captive screw plates are flush with the chassis.
4. Partially tighten the two captive screws on the front panel of the impedance carrier (either by hand or with the number 2 Phillips screwdriver or number 2 common (flat head) screwdriver) to make sure that they are both engaged.
5. Use the number 2 Phillips screwdriver or number 2 common (flat head) screwdriver to fully tighten the captive screws to seat the impedance carrier firmly in the slot.

### DETAILED STEPS

- 
- Step 1** Attach the ESD-preventive wrist strap to your wrist and connect its leash to one of the ESD connection sockets: on the front (PLIM) side of the chassis there is one ESD connection socket right above the fan controllers. On the rear (MSC) side of the chassis there are two ESD connection sockets right above the cable management tray in the center of the

chassis (left and right). You can also connect the ESD-preventive wrist strap leash to any bare metal surface on the chassis.

- Step 2** Use both hands while inserting an impedance carrier. Use one hand on the faceplate and the other hand along the base of the impedance carrier to guide it into a slot.
- Step 3** Slide the impedance carrier into the chassis until the captive screw plates are flush with the chassis.
- Step 4** Partially tighten the two captive screws on the front panel of the impedance carrier (either by hand or with the number 2 Phillips screwdriver or number 2 common (flat head) screwdriver) to make sure that they are both engaged.
- Step 5** Use the number 2 Phillips screwdriver or number 2 common (flat head) screwdriver to fully tighten the captive screws to seat the impedance carrier firmly in the slot.
- 

## What to Do Next

After performing this task, close the cosmetic doors, if installed.

## Removing an Impedance Carrier

This section describes how to remove an impedance carrier from the Cisco CRS Series Enhanced 16-Slot Line Card Chassis. Both types of impedance carrier types are removed in the same manner. [Figure 73: MSC Slot Impedance Carrier, on page 123](#) shows an MSC impedance carrier for reference. For more detailed information on impedance carriers, see the [About Impedance Carriers and Slot Covers, on page 113](#).

## Prerequisites

Before performing this task, open the cosmetic doors, if installed.

## Required Tools and Equipment

You need the following tools to perform this task:

- ESD-preventive wrist strap
- Number 2 Phillips screwdriver or number 2 common (flat head) screwdriver

## Steps

To remove an impedance carrier, perform the following steps:

## SUMMARY STEPS

1. Attach the ESD-preventive wrist strap to your wrist and connect its leash to one of the ESD connection sockets: on the front (PLIM) side of the chassis there is one ESD connection socket right above the fan controllers. On the rear (MSC) side of the chassis there are two ESD connection sockets right above the cable management tray in the center of the chassis (left and right). You can also connect the ESD-preventive wrist strap leash to any bare metal surface on the chassis.
2. Identify the impedance carrier to be removed from the card cage. Use the number 2 Phillips screwdriver or number 2 common (flat head) screwdriver to turn the two captive screws on the front panel of the card counterclockwise to loosen it from the slot.
3. Grasp the impedance carrier handle with one hand and gently pull it halfway from the slot.
4. Place one hand under the impedance carrier to guide it.
5. Holding the impedance carrier underneath and by the handle, pull it from the slot, and set it carefully aside.

## DETAILED STEPS

- 
- Step 1** Attach the ESD-preventive wrist strap to your wrist and connect its leash to one of the ESD connection sockets: on the front (PLIM) side of the chassis there is one ESD connection socket right above the fan controllers. On the rear (MSC) side of the chassis there are two ESD connection sockets right above the cable management tray in the center of the chassis (left and right). You can also connect the ESD-preventive wrist strap leash to any bare metal surface on the chassis.
- Step 2** Identify the impedance carrier to be removed from the card cage. Use the number 2 Phillips screwdriver or number 2 common (flat head) screwdriver to turn the two captive screws on the front panel of the card counterclockwise to loosen it from the slot.
- Step 3** Grasp the impedance carrier handle with one hand and gently pull it halfway from the slot.
- Step 4** Place one hand under the impedance carrier to guide it.
- Step 5** Holding the impedance carrier underneath and by the handle, pull it from the slot, and set it carefully aside.
- 

## What to Do Next

After performing this task, store the impedance carrier for future use. You may now install a card in the uncovered slot. See the [Installing an MSC, FP, or LSP Line Card, on page 152](#) and the [Installing a PLIM, on page 161](#) for further details.

# Installing an RP, PRP, or DRP Card

This section contains the following procedures:



### Warning

Class 1 Laser Product. Statement 113

---

**Warning**

---

Because invisible radiation may be emitted from the aperture of the port when no fiber cable is connected, avoid exposure to radiation and do not stare into open apertures. Statement 125

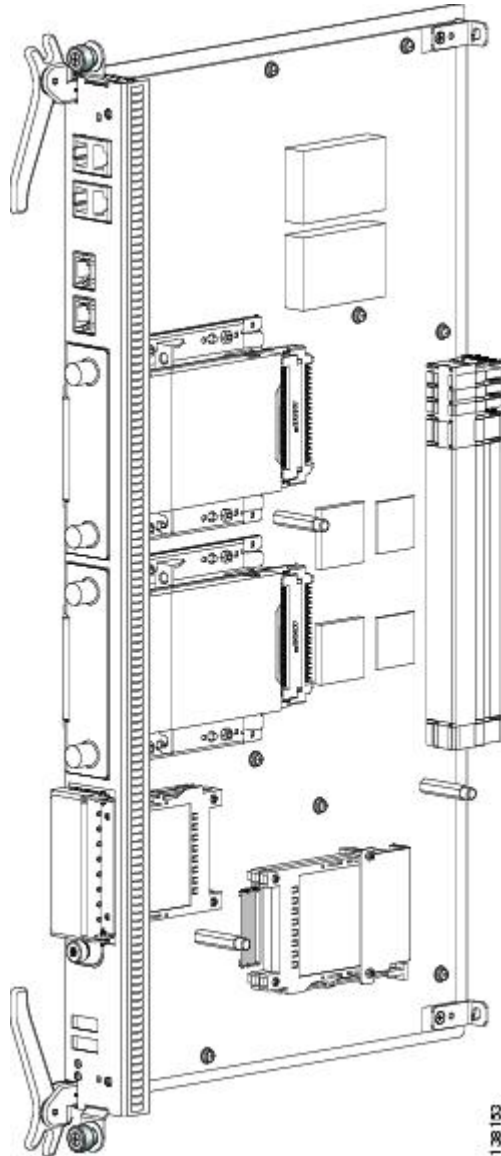
---

## About Distributed Route Processors and Distributed Route Processor PLIMs

The Cisco CRS Carrier Routing System provides distributed route processor (DRP) support through the installation of DRP PLIMs and DRP cards on the Cisco CRS Series Enhanced 16-Slot Line Card Chassis (see *Distributed Route Processor PLIM* and *Distributed Route Processor Card*). The installation of DRPs provides

you with the ability to configure the system for logical router support and additional processor power for multichassis systems.

**Figure 74: Distributed Route Processor PLIM**



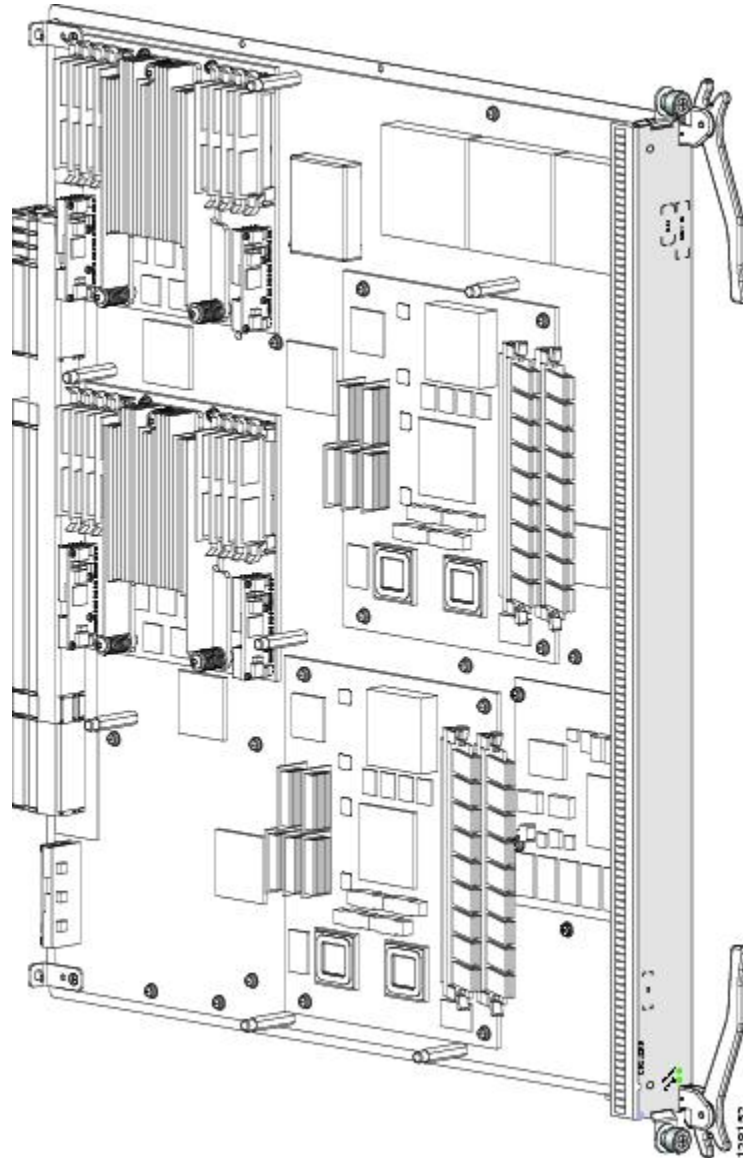
**Note**

The distributed route processor (DRP) card and DRP PLIM have no dedicated slots. The DRP card is installed in an open MSC slot and the DRP PLIM is installed in the corresponding PLIM slot.

For DRP support, you must install both the DRP PLIM in a PLIM slot on the front (PLIM) side of the chassis and a DRP card in the corresponding slot on the rear (MSC) side of the chassis. The DRP PLIM and DRP

cards are installed in the same manner as regular PLIMs and MSCs. See the [Installing a Line Card](#), on page 152 or the [Installing a PLIM](#), on page 161 for further information.

**Figure 75: Distributed Route Processor Card**



DRPs contain two CPU complexes, independent of each other, each with its own hard drive. In addition, the DRP provides you with two PCMCIA card slots, similar to the RP. For further information, see the [About Hard Drives and PCMCIA Cards](#), on page 117. For installation information, see the [Installing a Card-Based Hard Drive](#), on page 167 or the [Installing a PCMCIA Card](#), on page 168.

For more detailed information on the DRP PLIMs and DRP cards, see *Cisco CRS Series Enhanced 16-Slot Line Card Chassis System Description*.

## Installing an RP, PRP, or DRP Card

This section describes how to install a route processor (RP), performance route processor (PRP), or a DRP card in the Cisco CRS Series Enhanced 16-Slot Line Card Chassis. For more detailed information on route processor cards, see Cisco CRS Series Enhanced 16-Slot Line Card Chassis System Description.

Every Cisco CRS Series Enhanced 16-Slot Line Card Chassis contains two RP or PRP cards in dedicated slots on the PLIM side of the chassis.



---

**Note**

A chassis may not be populated with a mix of RP and PRP cards. Both route processor cards should be of the same type (RP or PRP). If you are using Cisco CRS-X, you must use only PRP cards.

---



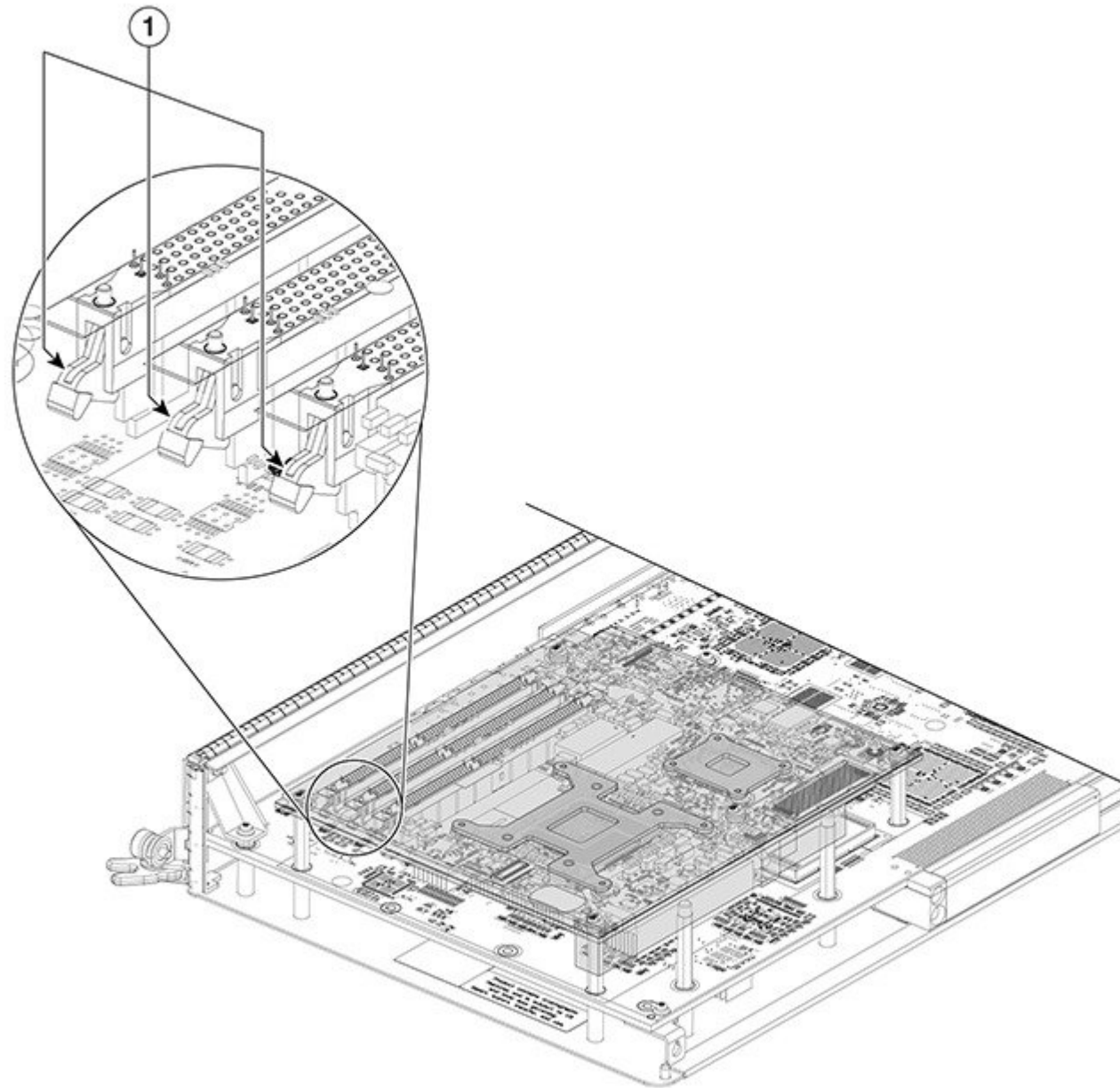
**Caution**

---

Be careful while handling the PRP line cards to avoid pressing the memory module latches on the daughter board and accidentally disengaging the memory modules. For the location of these latches, see the following figure.

---

*Figure 76: Memory Modules Latches on the Daughter Board*



1

Memory Module Latches

## Prerequisites

Because chassis operation may be impacted by the installation of a route processor card, perform these tasks only if one of the following conditions exists:

- When you are certain that the second RP in the chassis is operational and, if not already the master RP, ready to assume control (this happens automatically)
- When the chassis is undergoing scheduled maintenance
- When the Cisco CRS Series Enhanced 16-Slot Line Card Chassis is powered down

Failure to follow these guidelines can result in interruptions in data communications and network connectivity. Before performing this task, open the cosmetic doors, if installed.

## Required Tools and Equipment

You need the following tools and part to perform this task:

- ESD-preventive wrist strap
- Number 2 Phillips screwdriver or number 2 common (flat head) screwdriver
- RP, PRP, or DRP card:
  - RP card—Cisco product number: CRS-16-RP=
  - PRP card—Cisco product number: CRS-16-PRP-6G=
  - PRP card—Cisco product number: CRS-16-PRP-12G=
  - DRP card—Cisco product number: CRS-DRP-CPU=

## Steps

To install an RP, PRP, or DRP card, perform the following steps:

## SUMMARY STEPS

1. Attach the ESD-preventive wrist strap to your wrist and connect its leash to one of the ESD connection sockets: on the front (PLIM) side of the chassis there is one ESD connection socket right above the fan controllers. On the rear (MSC) side of the chassis there are two ESD connection sockets right above the cable management tray in the center of the chassis (left and right). You can also connect the ESD-preventive wrist strap leash to any bare metal surface on the chassis.
2. Remove the card from its antistatic packaging.
3. Identify the card to be replaced in the card cage. Remove any cables connected to the front panel of the RP card.
4. Use the number 2 Phillips screwdriver or number 2 common (flat head) screwdriver to turn the two captive screws on the front panel of the card counterclockwise to loosen the card from the slot.
5. Grasp the two card ejector levers and simultaneously pivot both ejector levers 90 degrees away from the front edge of the card carrier to unseat the card from the backplane connector.
6. Touching only the metal card carrier, slide the card from the slot and place it directly into an antistatic sack or other ESD-preventive container. If you plan to return the defective card to the factory, repackage it in the shipping container you received with the replacement card.
7. Grasp the card carrier handle with one hand and place your other hand under the carrier to support and guide it into the correct slot. Slide the card halfway into the slot. Avoid touching the card circuitry or any connectors.
8. Pivot both card ejector levers so that the openings on the card ejector cams at the top and bottom of the card pass over the tabs on each side of the card cage slot.
9. Continue sliding the card into the card cage slot until the openings on the card ejector cams engage the tabs on each side of the card cage slot.
10. To seat the card in the backplane connector, grasp both card ejector levers and pivot them inward toward the handle in the card carrier until they are flush against the front edge of the card carrier.
11. Use the number 2 Phillips screwdriver or number 2 common (flat head) screwdriver to turn the two captive screws on the front panel of the card clockwise to seat the card firmly in the slot.
12. Reattach any cables you removed in Step 3.

## DETAILED STEPS

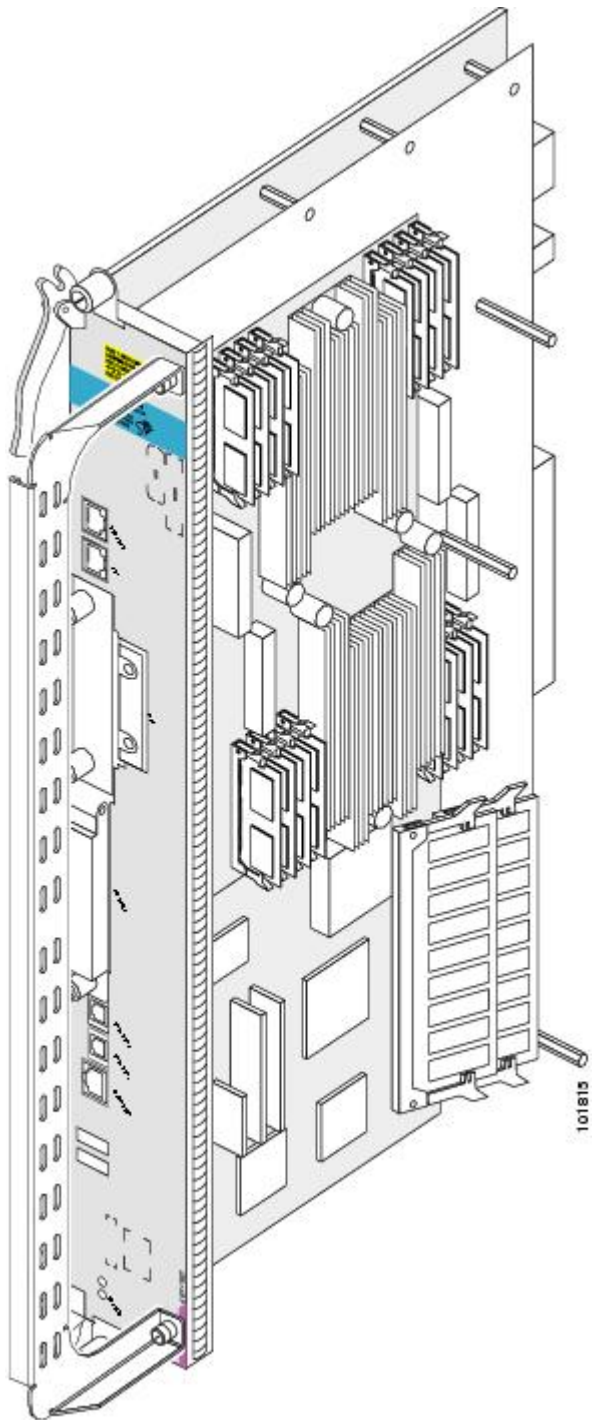
- 
- Step 1** Attach the ESD-preventive wrist strap to your wrist and connect its leash to one of the ESD connection sockets: on the front (PLIM) side of the chassis there is one ESD connection socket right above the fan controllers. On the rear (MSC) side of the chassis there are two ESD connection sockets right above the cable management tray in the center of the

chassis (left and right). You can also connect the ESD-preventive wrist strap leash to any bare metal surface on the chassis.

**Step 2** Remove the card from its antistatic packaging.

**Step 3** Identify the card to be replaced in the card cage. Remove any cables connected to the front panel of the RP card.

***Figure 77: Route Processor (RP) Card***



- Step 4** Use the number 2 Phillips screwdriver or number 2 common (flat head) screwdriver to turn the two captive screws on the front panel of the card counterclockwise to loosen the card from the slot.
- Step 5** Grasp the two card ejector levers and simultaneously pivot both ejector levers 90 degrees away from the front edge of the card carrier to unseat the card from the backplane connector.
- Step 6** Touching only the metal card carrier, slide the card from the slot and place it directly into an antistatic sack or other ESD-preventive container. If you plan to return the defective card to the factory, repackage it in the shipping container you received with the replacement card.
- Step 7** Grasp the card carrier handle with one hand and place your other hand under the carrier to support and guide it into the correct slot. Slide the card halfway into the slot. Avoid touching the card circuitry or any connectors.
- Note** Alignment grooves exist on each slot in the card cage. When you install a card in the card cage, make sure that you align both edges of the card carrier in the slot grooves.
- Step 8** Pivot both card ejector levers so that the openings on the card ejector cams at the top and bottom of the card pass over the tabs on each side of the card cage slot.
- Caution** Verify that the openings on the card ejector cams pass over the tabs; otherwise, one or both ejector levers might bind when you attempt to close the ejector levers, thereby damaging or breaking one or both ejector levers.
- Step 9** Continue sliding the card into the card cage slot until the openings on the card ejector cams engage the tabs on each side of the card cage slot.
- Note** RP and PRP cards have guide pins that make initial contact with the backplane connector as you slide the card into its slot. After the guide pins make contact, continue pushing on the card carrier until the card ejector levers begin pivoting forward toward the handle in the card carrier.
- Step 10** To seat the card in the backplane connector, grasp both card ejector levers and pivot them inward toward the handle in the card carrier until they are flush against the front edge of the card carrier.
- Step 11** Use the number 2 Phillips screwdriver or number 2 common (flat head) screwdriver to turn the two captive screws on the front panel of the card clockwise to seat the card firmly in the slot.
- Step 12** Reattach any cables you removed in Step 3.
- 

## What to Do Next

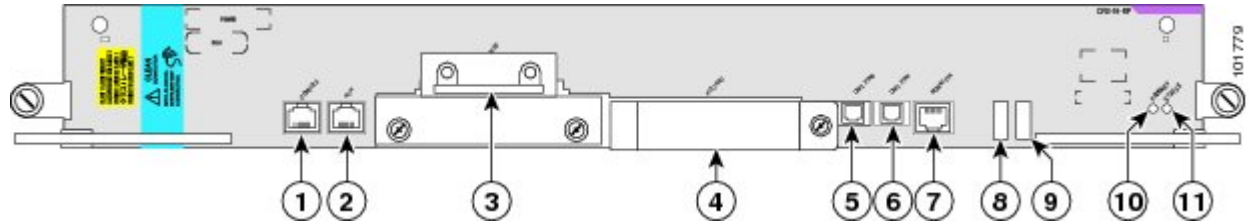
After performing this task, close the cosmetic doors, if installed, and verify that the card has been installed properly.

## Verifying the Installation of an RP, PRP, or DRP Card

This section describes how to verify and troubleshoot the installation of a route processor (RP), performance route processor (PRP), or distributed route processor (DRP) card in the Cisco CRS Series Enhanced 16-Slot Line Card Chassis. For more detailed information on the RP card, see Cisco CRS Series Enhanced 16-Slot Line Card Chassis System Description.

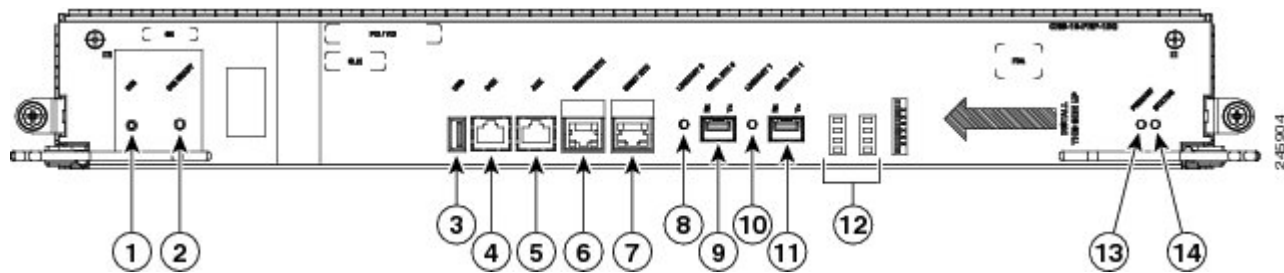
This section tells you how to verify that the card has been properly installed. The figure *RP Card Front Panel* shows the RP card front panel and *Performance Route Processor Front Panel* shows the PRP card front panel.

**Figure 78: RP Card Front Panel**



1	Console port	7	Management Ethernet RJ45 port
2	Aux port	8	Alphanumeric LED Display
3	Internal hard disk	9	Alphanumeric LED Display
4	PC card slot	10	PRIMARY LED—PRP active or standby indicator
5	Control Ethernet 0 port	11	STATUS LED—Card status indicator
6	Control Ethernet 1 port		

**Figure 79: Performance Route Processor Front Panel**



1	OIR push button—Press to initiate OIR process	8	Link/Active 0 LED
2	OIR Ready LED	9	Control Ethernet 0 port (SFP or SFP+)



3	USB socket	10	Link/Active 1 LED
4	Console port	11	Control Ethernet 1 port (SFP or SFP+)
5	Auxiliary port	12	Alphanumeric LED Display
6	Service Ethernet RJ45 port	13	PRIMARY LED—PRP active or standby indicator
7	Management Ethernet RJ45 port	14	STATUS LED—Card status indicator

## Understanding the Alphanumeric LEDs

On the card front panel, the RP, PRP, or DRP card has an alphanumeric LED display that shows a sequence of messages indicating the state of the card.



### Note

It is normal for some displayed messages to appear too briefly in the LED display to be read.

## Troubleshooting the RP, PRP, or DRP Card

If the installed or replaced card fails to operate or to power up on installation:

- Make sure that the card is seated firmly in the Cisco CRS Series Enhanced 16-Slot Line Card Chassis slot. One easy way to verify physical installation is to see whether the front faceplate of the card is even with the fronts of the other cards installed in the card cage.



### Note

PRP cards only—If the PRP is not seated properly, the blue OIR Ready LED on the faceplate glows solidly, and the PRIMARY and STATUS LEDs keep blinking to indicate that the card is not seated correctly. If this happens, remove the card fully and re-insert fully.

- Check whether the ejector levers are latched and that the captive screws are fastened properly. If you are uncertain, unlatch the levers, loosen the screws, and attempt to reseat the card.
- Examine the alarm module to see if there are any active alarm conditions. (See *Cisco CRS Series Enhanced 16-Slot Line Card Chassis System Description* for information on the alarm module.)
- Examine the power shelves to see whether the chassis, as a whole, is receiving power.

Use the card status LED, located on the RP and PRP card front panel, to verify the correct installation of the card:

- When the card is properly installed, the card status LED turns green. If this LED is off, verify that the card is installed correctly.
- When the card status LED is blinking yellow, a problem exists on the board.
- When the card status LED is off, the board status is unknown. Verify that there is power to the board by looking at the indicators on the power shelf.
- If a failure occurs during the board boot sequence, the four-digit alphanumeric display indicates the current boot phase to assist you in debugging the board failure.

## Installing a Fan Controller Card

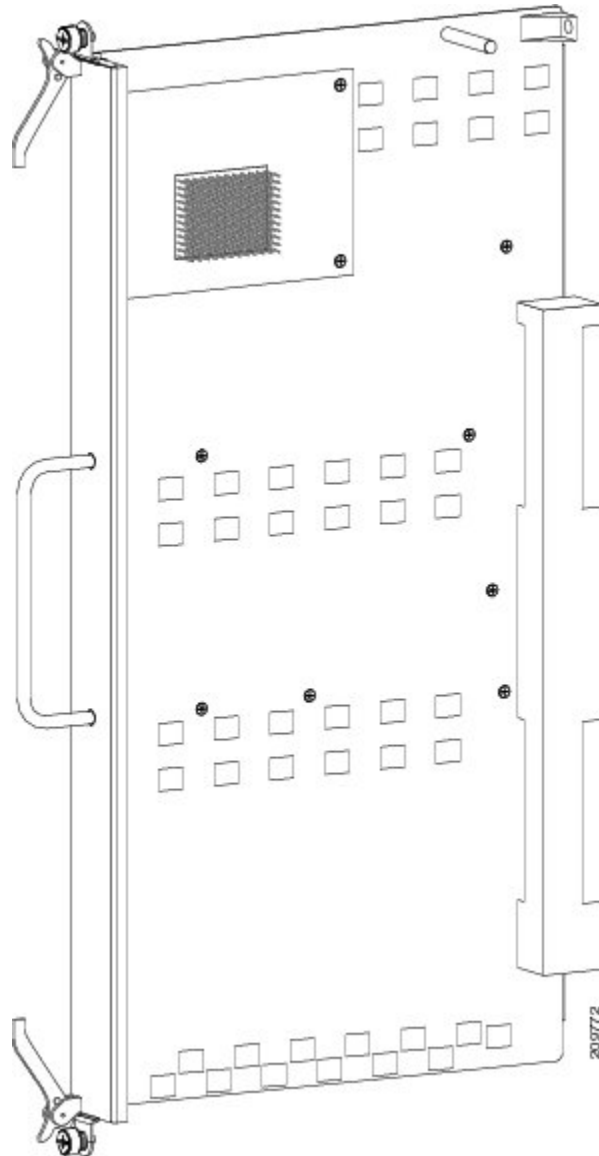
This section contains the following procedures:

### Installing a Cisco CRS Series Enhanced 16-Slot Line Card Chassis Fan Controller Card

This section describes how to install a Cisco CRS Series Enhanced 16-Slot Line Card Chassis fan controller (LCFC) card in the Cisco CRS Series Enhanced 16-Slot Line Card Chassis. For more detailed information on the Cisco CRS Series Enhanced 16-Slot Line Card Chassis fan controller card, see Cisco CRS Series Enhanced 16-Slot Line Card Chassis System Description.

Two Cisco CRS Series Enhanced 16-Slot Line Card Chassis fan controller cards, shown in the figure below, exist in every Cisco CRS Series Enhanced 16-Slot Line Card Chassis.

**Figure 80: Cisco CRS Series Enhanced 16-Slot Line Card Chassis Fan Controller Card**



## Prerequisites

Before performing this task, open the front (PLIM) cosmetic doors, if installed.

## Required Tools and Equipment

You need the following tools and part to perform this task:

- ESD-preventive wrist strap
- Number 2 Phillips screwdriver or number 2 common (flat head) screwdriver
- Cisco CRS Series Enhanced 16-Slot Line Card Chassis fan controller card—Cisco product number CRS-16-LCC-FAN-CT=

## Steps

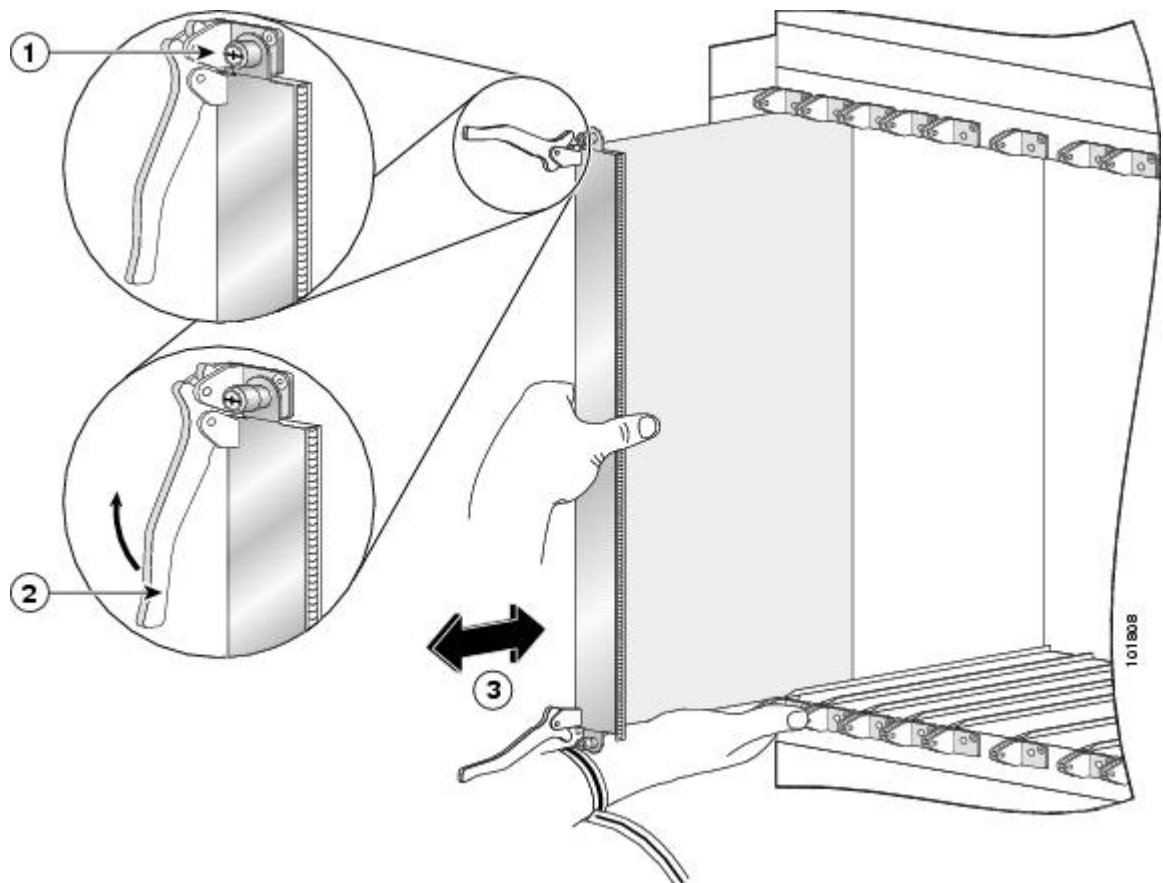
To install a Cisco CRS Series Enhanced 16-Slot Line Card Chassis fan controller card, see [Figure 81: Installing a Cisco CRS Series Enhanced 16-Slot Line Card Chassis Fan Controller Card](#), on page 142 and perform the following steps:



### Note

In the card installation figure, *Installing a Cisco CRS Series Enhanced 16-Slot Line Card Chassis Fan Controller Card*, an Impedance Carrier is shown. Refer to figure *Cisco CRS Series Enhanced 16-Slot Line Card Chassis Fan Controller Card Front Panel* for an example of the actual Cisco CRS Series Enhanced 16-Slot Line Card Chassis fan controller card.

**Figure 81: Installing a Cisco CRS Series Enhanced 16-Slot Line Card Chassis Fan Controller Card**



1	Captive screw	3	Direction of installation or removal
2	Ejector lever		

## SUMMARY STEPS

1. Attach the ESD-preventive wrist strap to your wrist and connect its leash to one of the ESD connection sockets: on the front (PLIM) side of the chassis there is one ESD connection socket right above the fan controllers. On the rear (MSC) side of the chassis there are two ESD connection sockets right above the cable management tray in the center of the chassis (left and right). You can also connect the ESD-preventive wrist strap leash to any bare metal surface on the chassis.
2. Remove the impedance carrier card from the available slot in which you plan to install the Cisco CRS Series Enhanced 16-Slot Line Card Chassis fan controller card.
3. Remove the Cisco CRS Series Enhanced 16-Slot Line Card Chassis fan controller card from its antistatic packaging.
4. Grasp the card carrier handle with one hand and place your other hand under the carrier to support and guide it into the correct slot.
5. Slide the card halfway into the slot. Avoid touching the card circuitry or any connectors.
6. Pivot both card ejector levers so that the openings on the card ejector cams at the top and bottom of the card pass over the tabs on each side of the card cage slot.
7. Continue sliding the card into the card cage slot until the openings on the card ejector cams engage the tabs on each side of the slot.
8. To seat the card in the midplane connector, grasp both card ejector levers and pivot them inward toward the handle in the card carrier until they are flush against the front edge of the card carrier.
9. Use the number 2 Phillips screwdriver or number 2 common (flat head) screwdriver to turn the two captive screws on the front panel of the Cisco CRS Series Enhanced 16-Slot Line Card Chassis fan controller card clockwise to seat the card firmly in the slot.

## DETAILED STEPS

- 
- Step 1** Attach the ESD-preventive wrist strap to your wrist and connect its leash to one of the ESD connection sockets: on the front (PLIM) side of the chassis there is one ESD connection socket right above the fan controllers. On the rear (MSC) side of the chassis there are two ESD connection sockets right above the cable management tray in the center of the chassis (left and right). You can also connect the ESD-preventive wrist strap leash to any bare metal surface on the chassis.
- Step 2** Remove the impedance carrier card from the available slot in which you plan to install the Cisco CRS Series Enhanced 16-Slot Line Card Chassis fan controller card.
- Step 3** Remove the Cisco CRS Series Enhanced 16-Slot Line Card Chassis fan controller card from its antistatic packaging.
- Step 4** Grasp the card carrier handle with one hand and place your other hand under the carrier to support and guide it into the correct slot.  
**Note** For easier installation, install the far left card first.
- Step 5** Slide the card halfway into the slot. Avoid touching the card circuitry or any connectors.

- Note** Alignment grooves exist on each slot in the card cage. When you install a card in the card cage, make sure that you align both edges of the card carrier in the slot grooves.
- Step 6** Pivot both card ejector levers so that the openings on the card ejector cams at the top and bottom of the card pass over the tabs on each side of the card cage slot.
- Caution** Verify that the openings on the card ejector cams pass over the tabs; otherwise, one or both ejector levers might bind when you attempt to close the levers, thereby damaging or breaking one or both of them.
- Step 7** Continue sliding the card into the card cage slot until the openings on the card ejector cams engage the tabs on each side of the slot.
- Note** The Cisco CRS Series Enhanced 16-Slot Line Card Chassis fan controller card has guide pins that make initial contact with the midplane connector as you slide a card into its slot. After the guide pins make contact, continue pushing the card carrier until the card ejector levers begin pivoting forward, toward the handle in the card carrier.
- Step 8** To seat the card in the midplane connector, grasp both card ejector levers and pivot them inward toward the handle in the card carrier until they are flush against the front edge of the card carrier.
- Note** For easier installation, install both Cisco CRS Series Enhanced 16-Slot Line Card Chassis fan controller cards before you tighten the fasteners.
- Step 9** Use the number 2 Phillips screwdriver or number 2 common (flat head) screwdriver to turn the two captive screws on the front panel of the Cisco CRS Series Enhanced 16-Slot Line Card Chassis fan controller card clockwise to seat the card firmly in the slot.

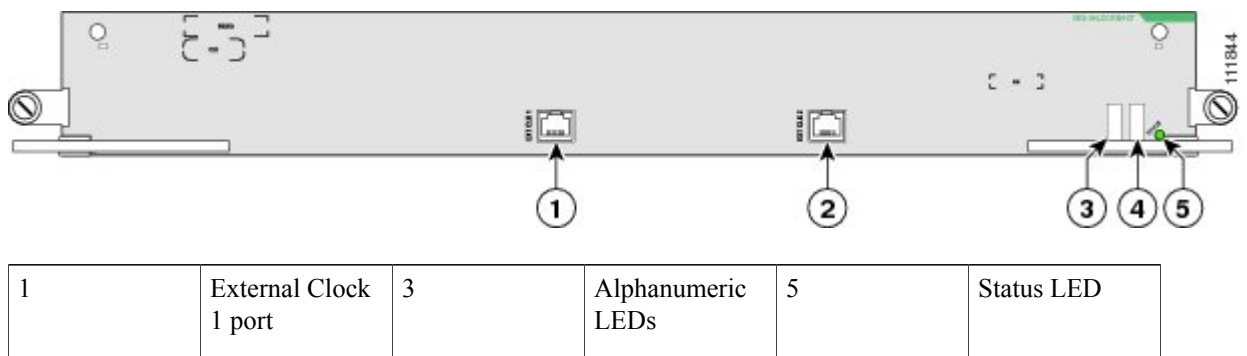
## What to Do Next

After performing this task, place the impedance carrier in an antistatic bag for storage and future use. Close the front (PLIM) side cosmetic doors and verify that the card has been installed properly (see the [Verifying the Installation of a Cisco CRS Series Enhanced 16-Slot Line Card Chassis Fan Controller Card](#), on page 144).

## Verifying the Installation of a Cisco CRS Series Enhanced 16-Slot Line Card Chassis Fan Controller Card

This section describes how to verify that the Cisco CRS Series Enhanced 16-Slot Line Card Chassis fan controller card has been properly installed. This figure is an illustration of the Cisco CRS Series Enhanced 16-Slot Line Card Chassis fan controller front panel.

*Figure 82: Cisco CRS Series Enhanced 16-Slot Line Card Chassis Fan Controller Card Front Panel*



2	External Clock 2 port	4	Alphanumeric LEDs		
---	--------------------------	---	----------------------	--	--

## Understanding the Alphanumeric LEDs

At one end of the faceplate, near an ejector lever, a Cisco CRS Series Enhanced 16-Slot Line Card Chassis fan controller card has two four-digit alphanumeric LED displays that show a sequence of messages indicating the state of the card.



### Note

It is normal for some displayed messages to appear too briefly in the LED display to be read.

## Troubleshooting the Cisco CRS Series Enhanced 16-Slot Line Card Chassis Fan Controller Card

If the installed or replaced Cisco CRS Series Enhanced 16-Slot Line Card Chassis fan controller card fails to operate or to power up on installation:

- Make sure that the card is seated firmly in the Cisco CRS Series Enhanced 16-Slot Line Card Chassis slot. One easy way to verify physical installation is to see whether the front faceplate of the Cisco CRS Series Enhanced 16-Slot Line Card Chassis fan controller card is even with the fronts of the other cards installed in the card cage.
- Check whether the ejector levers are latched and that the captive screws are fastened properly. If you are uncertain, unlatch the levers, loosen the screws, and attempt to reseat the Cisco CRS Series Enhanced 16-Slot Line Card Chassis fan controller card.
- Examine the alarm module to see if there are any active alarm conditions. (See Cisco CRS Series Enhanced 16-Slot Line Card Chassis System Description.)
- Examine the power shelves to see whether the chassis, as a whole, is receiving power.

Use the Status LED, located on the Cisco CRS Series Enhanced 16-Slot Line Card Chassis fan controller card faceplate, to verify the correct installation of the card:

- When the card is properly installed, the Status LED turns green. If this LED is off, verify that the card is installed correctly.
- When the Status LED is blinking yellow, a problem exists on the board.
- When the Status LED is off, the board status is unknown. Verify that there is power to the board by looking at the indicators on the power shelf.
- If a failure occurs during the board boot sequence, the two four-digit alphanumeric display indicate the current boot phase to assist you in debugging the board failure.

## Installing a Switch Fabric Card

This section contains the following procedures:

**Note**

Some switch fabric cards (SFCs) contain Class 1 lasers, while others contain Class 1M lasers; for details on the specifics of your card, see Cisco CRS Series Enhanced 16-Slot Line Card Chassis System Description.

**Warning**

Class 1 Laser Product. Statement 113

**Warning**

Because invisible radiation may be emitted from the aperture of the port when no fiber cable is connected, avoid exposure to radiation and do not stare into open apertures. Statement 125

**Caution**

Class 1M laser radiation when open. Do not view directly with optical instruments. Statement 281

**Warning**

For diverging beams, viewing the laser output with certain optical instruments within a distance of 100 mm may pose an eye hazard. For collimated beams, viewing the laser output with certain optical instruments designed for use at a distance may pose an eye hazard. Statement 282

**Warning**

Laser radiation. Do not view directly with optical instruments. Class 1M laser product. Statement 283

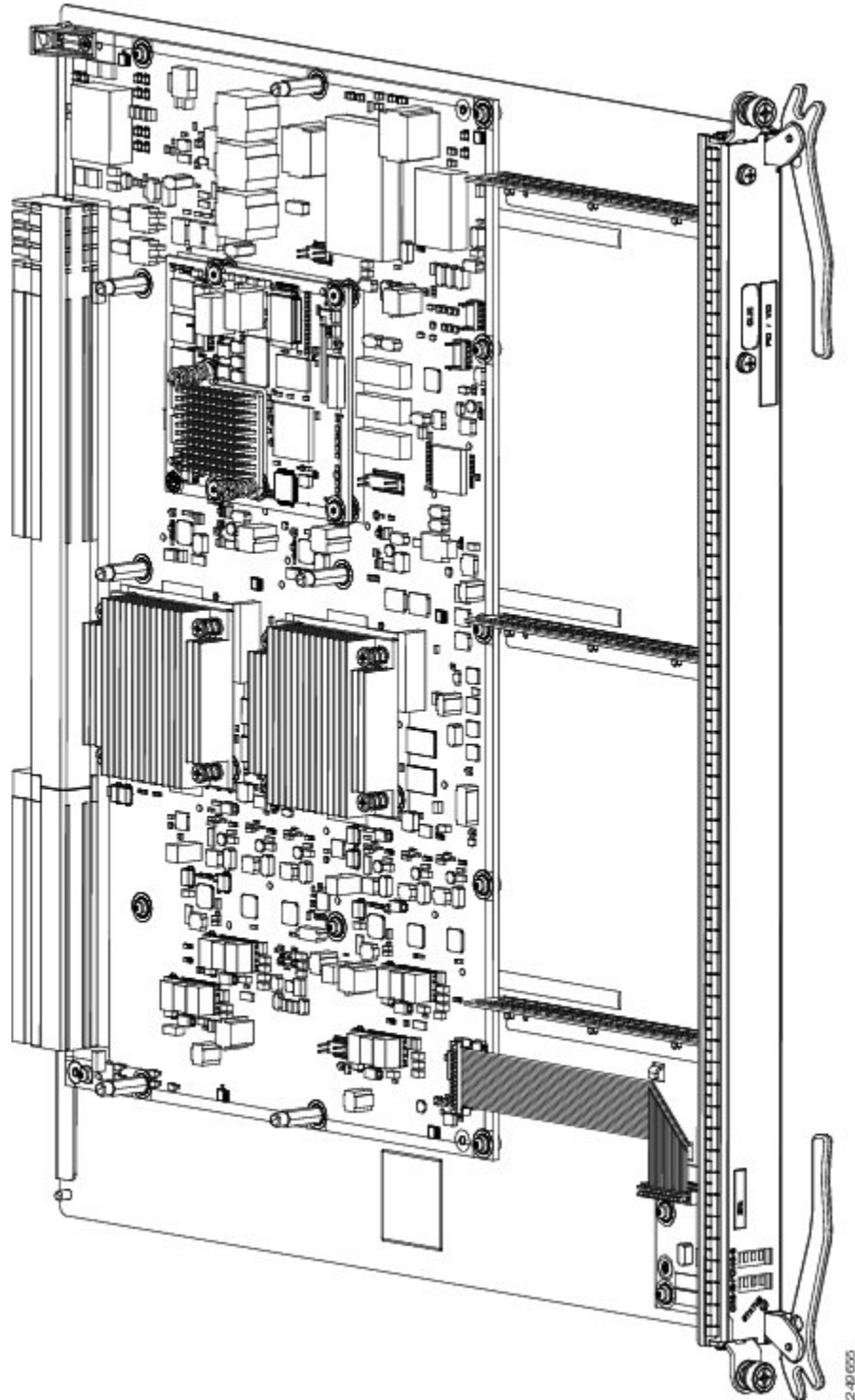
## Installing a Switch Fabric Card

This section describes how to install a switch fabric card (SFC) in the Cisco CRS Series Enhanced 16-Slot Line Card Chassis. For more detailed information on the different types of switch fabric cards available and details on the cards themselves, see Cisco CRS Series Enhanced 16-Slot Line Card Chassis System Description.



This figure shows the FQ123-140G switch fabric card for a single-chassis system (in other words, a system that has only a single Cisco CRS Series Enhanced 16-Slot Line Card Chassis).

**Figure 83: FQ123 -140G Switch Fabric Card**



## Prerequisites

Before performing this task, open the front (PLIM) side cosmetic doors, if installed.

## Required Tools and Equipment

You need the following tools and part to perform this task:

- ESD-preventive wrist strap
- Number 2 Phillips screwdriver or number 2 common (flat head) screwdriver
- Switch fabric card:
  - FQ123—Cisco product number: CRS-16-FC/S=

or

- ◦ FQ123-140G—Cisco product number: CRS-16-FC140/S=

or

- ◦ FQ123-400G—Cisco product number: CRS-16-FC400/S=

## Steps

To install a switch fabric card, perform the following steps:

## SUMMARY STEPS

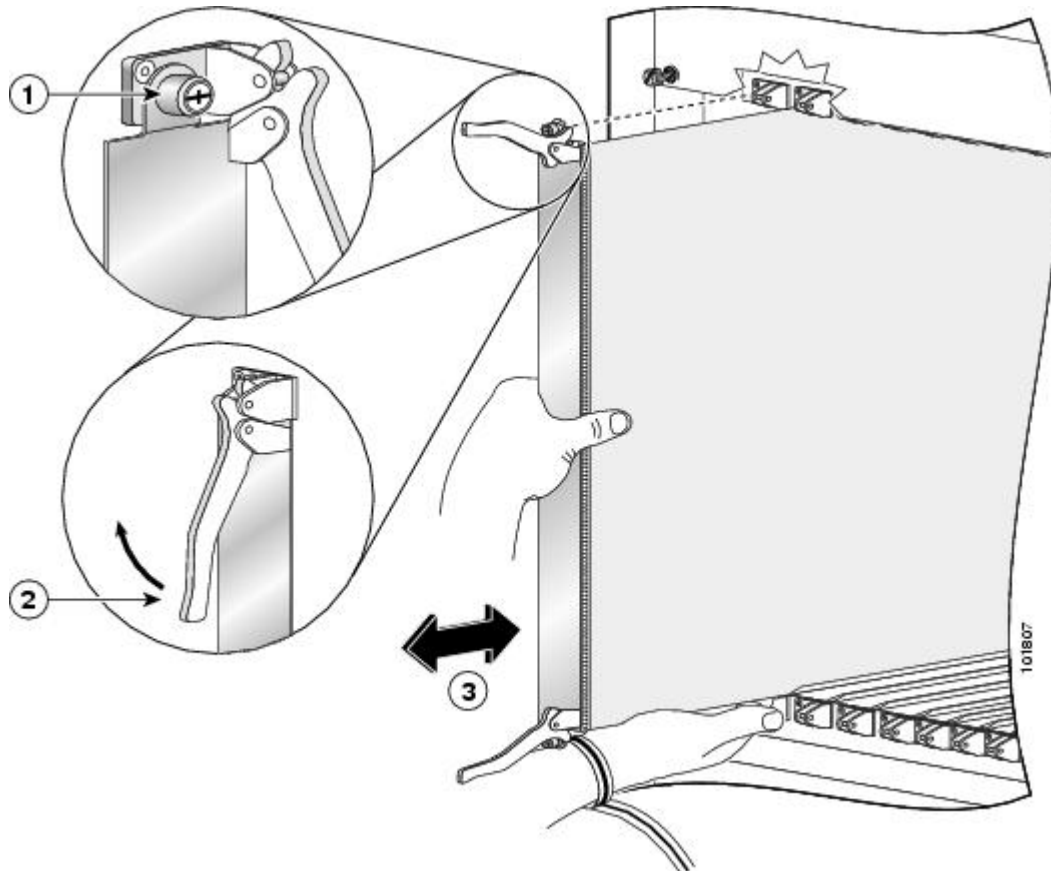
1. Attach the ESD-preventive wrist strap to your wrist and connect its leash to one of the ESD connection sockets: on the front (PLIM) side of the chassis there is one ESD connection socket right above the fan controllers. On the rear (MSC) side of the chassis there are two ESD connection sockets right above the cable management tray in the center of the chassis (left and right). You can also connect the ESD-preventive wrist strap leash to any bare metal surface on the chassis.
2. Remove the switch fabric card from its antistatic packaging.
3. Grasp the card carrier handle with one hand and place your other hand under the carrier to support and guide it into the correct slot (see figure *Installing a Switch Fabric Card*).
4. Position the card for insertion into the card cage slot. Avoid touching the card circuitry or any connectors.
5. Orient the switch fabric card so that the PCB faces left and the carrier is to the right; if the card does not slide easily into the slot, the orientation may be wrong and the misorientation rejection flange is stopping the card from going into the slot. Reorient the switch fabric card, if necessary.
6. Carefully slide the switch fabric card into the slot until the ejector levers meet the edges of the card cage, then *stop* when the ejector lever hooks catch the pillow block in the card cage. If they do not catch, try reinserting the switch fabric card until the ejector lever hooks are fully latched.
7. Pivot both card ejector levers so that the openings on the card ejector cams at the top and bottom of the card pass over the tabs on each side of the card cage slot.
8. Continue sliding the card into the card cage slot until the openings on the card ejector cams engage the tabs on each side of the card cage slot.
9. To seat the card in the midplane connector, grasp both card ejector levers and pivot them inward toward the handle in the card carrier until they are flush against the front edge of the card carrier.
10. Use the number 2 Phillips screwdriver or number 2 common (flat head) screwdriver to turn the two captive screws on the front panel of the card clockwise to seat the card firmly in the slot.

## DETAILED STEPS

- 
- Step 1** Attach the ESD-preventive wrist strap to your wrist and connect its leash to one of the ESD connection sockets: on the front (PLIM) side of the chassis there is one ESD connection socket right above the fan controllers. On the rear (MSC) side of the chassis there are two ESD connection sockets right above the cable management tray in the center of the chassis (left and right). You can also connect the ESD-preventive wrist strap leash to any bare metal surface on the chassis.
- Step 2** Remove the switch fabric card from its antistatic packaging.
- Step 3** Grasp the card carrier handle with one hand and place your other hand under the carrier to support and guide it into the correct slot (see figure *Installing a Switch Fabric Card*).
- Note** For easiest installation, install the cards from right to left sequentially, starting from the far right slot.
- Note** In the switch fabric card installation figure, an Impedance Carrier is shown. Refer to [Figure 83: FQ123 -140G Switch Fabric Card](#), on page 147 for an example of the actual switch fabric card.
- Step 4** Position the card for insertion into the card cage slot. Avoid touching the card circuitry or any connectors.

**Note** Alignment grooves exist on each slot in the card cage. When you install a card in the card cage, make sure that you align both edges of the card carrier in the slot grooves.

**Figure 84: Installing a Switch Fabric Card**



1	Captive screw	3	Direction of installation or removal
2	Ejector lever		

**Step 5** Orient the switch fabric card so that the PCB faces left and the carrier is to the right; if the card does not slide easily into the slot, the orientation may be wrong and the misorientation rejection flange is stopping the card from going into the slot. Reorient the switch fabric card, if necessary.

**Step 6** Carefully slide the switch fabric card into the slot until the ejector levers meet the edges of the card cage, then *stop* when the ejector lever hooks catch the pillow block in the card cage. If they do not catch, try reinserting the switch fabric card until the ejector lever hooks are fully latched.

**Step 7** Pivot both card ejector levers so that the openings on the card ejector cams at the top and bottom of the card pass over the tabs on each side of the card cage slot.

**Caution** Verify that the openings on the card ejector cams pass over the tabs; otherwise, one or both ejector levers might bind when you attempt to close the levers, thereby damaging or breaking one or both of them.

- Step 8** Continue sliding the card into the card cage slot until the openings on the card ejector cams engage the tabs on each side of the card cage slot.
- Note** Switch fabric cards have guide pins that make initial contact with the midplane connector as you slide a card into its slot. After the guide pins make contact, continue pushing the card carrier until the card ejector levers begin pivoting forward, toward the handle in the card carrier.
- Step 9** To seat the card in the midplane connector, grasp both card ejector levers and pivot them inward toward the handle in the card carrier until they are flush against the front edge of the card carrier.
- Note** For easier installation, install all four switch fabric cards in each bay before securing any fasteners.
- Step 10** Use the number 2 Phillips screwdriver or number 2 common (flat head) screwdriver to turn the two captive screws on the front panel of the card clockwise to seat the card firmly in the slot.

## What to Do Next

After performing this task, place the impedance carrier in an antistatic bag for storage and future use. Close the front (PLIM) side cosmetic doors, if installed, and verify that the card has been installed properly (see the next section *Verifying the Installation of a Switch Fabric Card*). If you are performing the initial installation of the system, install the MSCs (see the [Installing an MSC, FP, or LSP Line Card](#), on page 152) after you complete the installation of the switch fabric cards.

## Verifying the Installation of a Switch Fabric Card

This section tells you how to verify that a switch fabric card (SFC) has been properly installed. This figure shows an FQ123-140G switch fabric card for a single-chassis system (in other words, a system that has only a single Cisco CRS Series Enhanced 16-Slot Line Card Chassis). The FQ123 SFC is similar.

**Figure 85: FQ123-140G Switch Fabric Card Front View**



1	Status LED	2	Alphanumeric LEDs
---	------------	---	-------------------

## Understanding the Alphanumeric LEDs

At one end of the faceplate, near an ejector lever, a switch fabric card has two four-digit alphanumeric LED displays that show a sequence of messages indicating the state of the card.

**Note**


---

It is normal for some displayed messages to appear too briefly in the LED display to be read.

---

## Troubleshooting the Switch Fabric Card

If the installed or replaced switch fabric card fails to operate or power up on installation:

- Make sure that the card is seated firmly in the Cisco CRS Series Enhanced 16-Slot Line Card Chassis slot. One easy way to verify physical installation is to see whether the front faceplate of the switch fabric card is even with the fronts of the other cards installed in the card cage.
- Check whether the ejector levers are latched and that the captive screws are fastened properly. If you are uncertain, unlatch the levers, loosen the screws, and attempt to reseat the switch fabric card.
- Examine the alarm module to see if there are any active alarm conditions. See *Cisco CRS Series Enhanced 16-Slot Line Card Chassis System Description* for information on the alarm module.
- Examine the power shelves to see whether the chassis, as a whole, is receiving power.

Use the Status LED, located on the switch fabric card faceplate, to verify the correct installation of the card:

- When the card is properly installed, the Status LED turns green. If this LED is off, verify that the card is installed correctly.
- When the Status LED is blinking yellow, a problem exists on the board.
- When the Status LED is off, the board status is unknown. Verify that there is power to the board by looking at the indicators on the power shelf.
- If a failure occurs during the board boot sequence, the two four-digit alphanumeric displays indicate the current boot phase to assist you in debugging the board failure.

## Installing a Line Card

This section contains the following procedures:

### Installing an MSC, FP, or LSP Line Card

This section describes how to install a modular services card (MSC), forwarding processor (FP) card, or label switch processor (LSP) in the Cisco CRS Series Enhanced 16-Slot Line Card Chassis. For more detailed information on the MSC, see *Cisco CRS Series Enhanced 16-Slot Line Card Chassis System Description*.

The MSC, FP, and LSP are Layer 3 forwarding engines.

- The MSCs include: CRS-MSC, CRS-MSC-B, CRS-MSC-140G, and CRS-MSC-X (400G).
- The FPs include: CRS-FP-140, CRS-FP-X (400G).
- The LSPs include: CRS-LSP, CRS-LSP-X (400G).

The card versions provide different scale and feature capabilities to address requirements of different positions in the network.

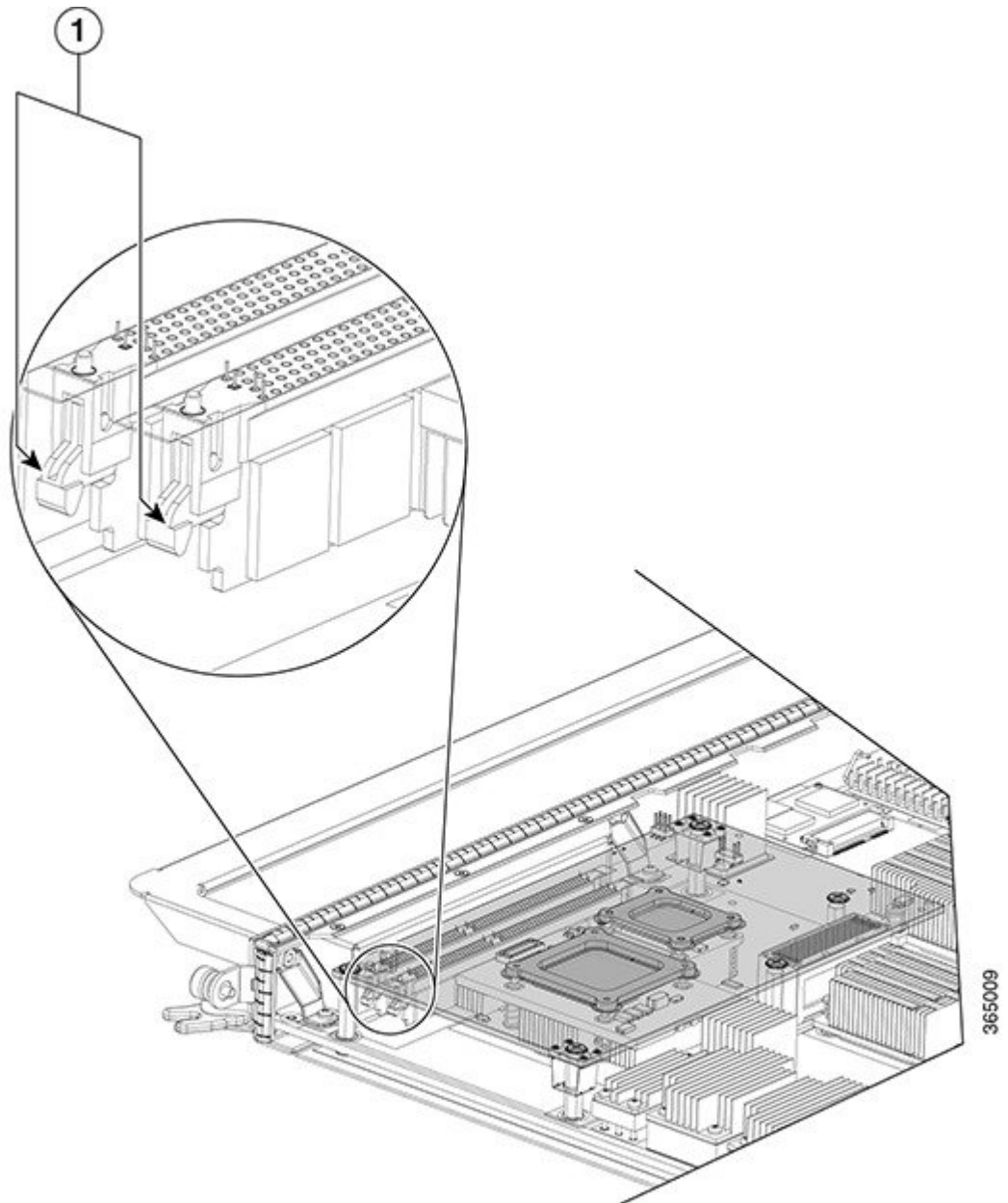
**Caution**

---

Be careful while handling these line cards to avoid pressing the memory module latches on the daughter board and accidentally disengaging the memory modules. For the location of these latches, see the following figure.

---

***Figure 86: Memory Modules Latches on the Daughter Board***



1

Memory Module Latches

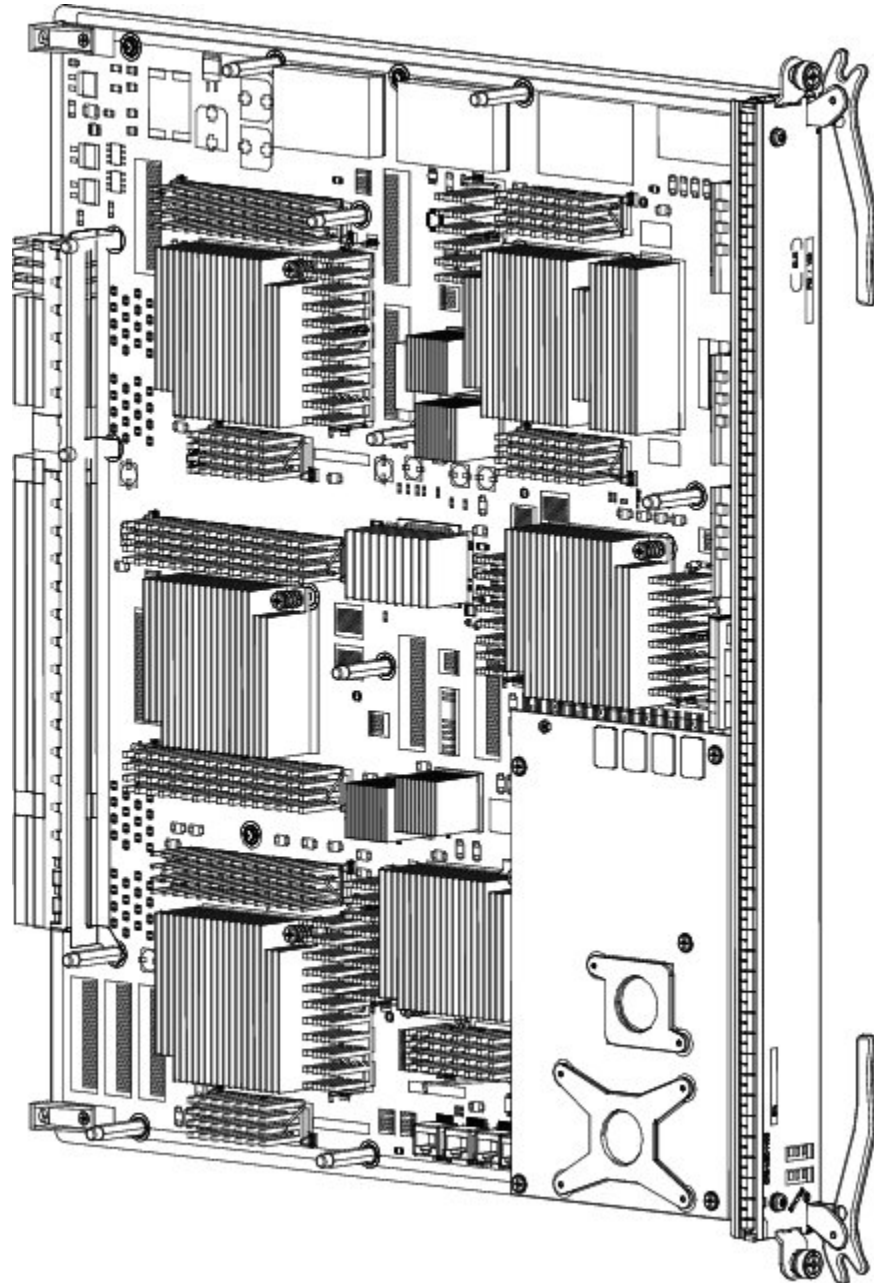
This figure shows the CRS-MSC-140G MSC. The other MSCs and the FP and LSP cards are similar.



**Caution**

MSC-140G, FP-140, and LSP line cards should only be paired with 20-port and 14-port 10-GE XFP PLIMs and 1-port 100-GE CFP PLIMs. The MSC-40 line card should not be paired with 20-port and 14-port 10-GE XFP PLIMs or 1-port 100-GE CFP PLIMs. The MSC-40 line card can be paired with all previous PLIMs. See the release notes for details.

**Figure 87: Modular Services Card (CRS-MSC-140G)**



## Prerequisites

Before performing this task, open the cosmetic doors, if installed.

**Caution**

---

Remove or install only one modular services card at a time. Allow at least 15 seconds for the router to complete the preceding tasks before removing or installing another modular services card. The router may indicate a hardware failure if you do not follow proper procedures.

---

**Caution**

---

Do not carry a line card by the bracket attached to the faceplate.

---

## Required Tools and Equipment

You need the following tools and part to perform this task:

- ESD-preventive strap
- Number 2 Phillips screwdriver or number 2 common (flat head) screwdriver
- MSC, FP, or LSP (see the product data sheet for ordering details).

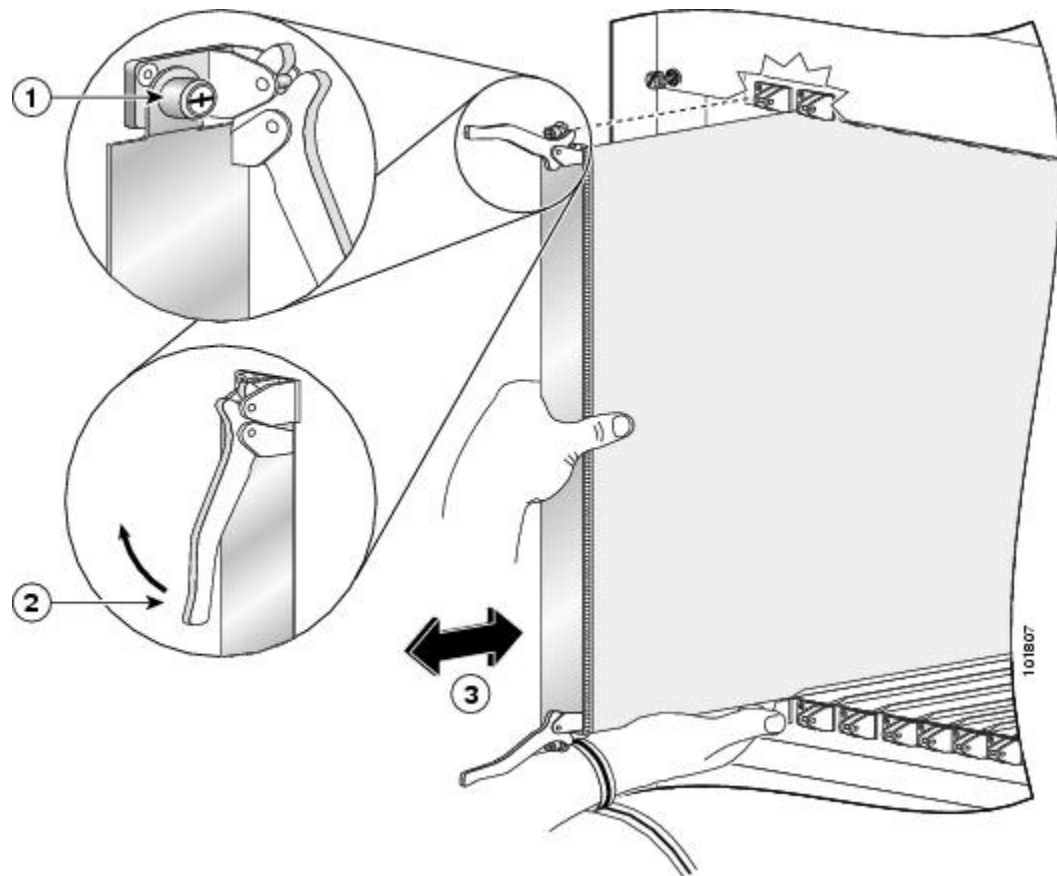
## Steps

To install a line card, see the below figure and perform the following steps:

**Note**

In the card installation figure below, an Impedance Carrier is shown. Refer to [Figure 89: CRS-MSC-140G Front Panel](#), on page 159 and [Figure 90: CRS-FP140 Front Panel](#), on page 160 for examples of the actual Modular Service Cards (MSCs).

**Figure 88: Installing a Line Card**



1	Captive screw	3	Direction of installation or removal
2	Ejector lever		

## SUMMARY STEPS

1. Attach the ESD-preventive wrist strap to your wrist and connect its leash to one of the ESD connection sockets: on the front (PLIM) side of the chassis there is one ESD connection socket right above the fan controllers. On the rear (MSC) side of the chassis there are two ESD connection sockets right above the cable management tray in the center of the chassis (left and right). You can also connect the ESD-preventive wrist strap leash to any bare metal surface on the chassis.
2. Choose an available modular services card slot for the line card.
3. Remove the MSC impedance carrier from the slot you need to fill and set it aside.
4. Remove the replacement line card from the antistatic bag or mat.
5. Use both hands while inserting a line card. Use one hand on the faceplate and the other hand along the base of the line card to guide it into a slot.
6. Orient the line card so that the PCB faces left and the carrier is to the right; if the card does not slide easily into the slot, the orientation may be wrong and the misorientation rejection flange is stopping the card from going into the slot. Reorient the line card, if necessary.
7. Make sure that the ejector levers are oriented properly to engage with the pin as the line card slides into the slot. Carefully slide the line card into the slot until the ejector levers engage the catches, then *stop*.
8. Simultaneously pivot the ejector levers toward the faceplate of the line card. Do not force the line card; the ejector levers properly seat the line card against the midplane.
9. Use a number 2 Phillips screwdriver or number 2 common (flat head) screwdriver to tighten the captive screws next to each line card ejector lever to ensure proper EMI shielding and prevent the line card from becoming partially dislodged from the midplane.
10. Attach the bracket to the line card; use the screws that came with it.

## DETAILED STEPS

- 
- Step 1** Attach the ESD-preventive wrist strap to your wrist and connect its leash to one of the ESD connection sockets: on the front (PLIM) side of the chassis there is one ESD connection socket right above the fan controllers. On the rear (MSC) side of the chassis there are two ESD connection sockets right above the cable management tray in the center of the chassis (left and right). You can also connect the ESD-preventive wrist strap leash to any bare metal surface on the chassis.
- Step 2** Choose an available modular services card slot for the line card.
- Caution** To prevent ESD damage, handle a modular services card by its ejector levers or the line card carrier edges only. Do not touch any of the electrical components, pins, or circuitry.
- Step 3** Remove the MSC impedance carrier from the slot you need to fill and set it aside.
- Note** Remove only one impedance carrier and install one line card at a time. Be sure to verify that each line card is fully installed and secured before installing another card.

- Step 4** Remove the replacement line card from the antistatic bag or mat.
- Step 5** Use both hands while inserting a line card. Use one hand on the faceplate and the other hand along the base of the line card to guide it into a slot.
- Step 6** Orient the line card so that the PCB faces left and the carrier is to the right; if the card does not slide easily into the slot, the orientation may be wrong and the misorientation rejection flange is stopping the card from going into the slot. Reorient the line card, if necessary.
- Step 7** Make sure that the ejector levers are oriented properly to engage with the pin as the line card slides into the slot. Carefully slide the line card into the slot until the ejector levers engage the catches, then *stop*.
- Step 8** Simultaneously pivot the ejector levers toward the faceplate of the line card. Do not force the line card; the ejector levers properly seat the line card against the midplane.
- Note** If the captive screws are difficult to tighten, ensure that each ejector lever is properly secured to each catch and that the line card is properly seated in the slot.
- Step 9** Use a number 2 Phillips screwdriver or number 2 common (flat head) screwdriver to tighten the captive screws next to each line card ejector lever to ensure proper EMI shielding and prevent the line card from becoming partially dislodged from the midplane.
- Caution** To ensure adequate space for additional PLIMs or line cards, always tighten the captive installation screws on each newly installed PLIM *before* you insert any additional PLIM or line card. These screws also prevent accidental removal and provide proper grounding and EMI shielding for the system.
- Step 10** Attach the bracket to the line card; use the screws that came with it.

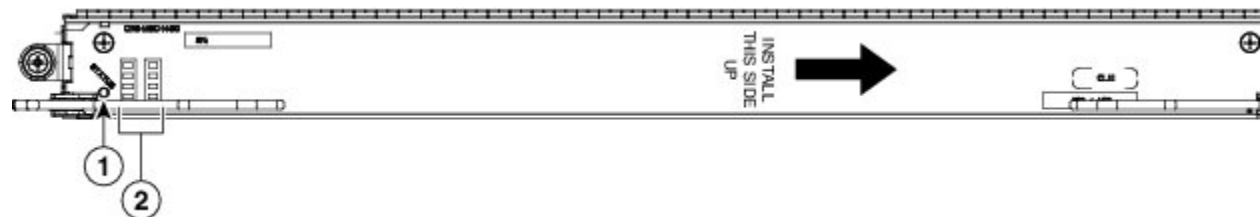
## What to Do Next

After performing this task, place the impedance carrier in an antistatic bag for storage and future use. Close the cosmetic doors, if installed, and verify that the card has been installed properly (see the next section *Verifying the Installation of an MSC, FP, or LSP Line Card*). If you are performing the initial installation of the system, install the PLIMs (see the [Installing a PLIM, on page 161](#)) after you complete the installation of the line cards.

## Verifying the Installation of an MSC, FP, or LSP Line Card

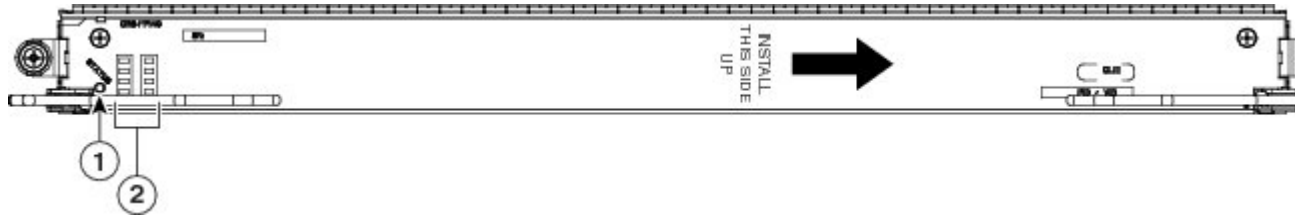
This section describes how to verify that a line card has been properly installed. *CRS-MSC-140G Front Panel* is an illustration of the MSC-140G front panel. *CRS-FP140 Front Panel* shows the FP-140 front panel. The other MSC, FP, and LSP cards are similar.

**Figure 89: CRS-MSC-140G Front Panel**



1	Status LED	2	Alphanumeric LEDs
---	------------	---	-------------------

Figure 90: CRS-FP140 Front Panel



1	Status LED	2	Alphanumeric LEDs
---	------------	---	-------------------

## Understanding the Alphanumeric LEDs

At one end of the faceplate, near an ejector lever, an MSC has two four-digit alphanumeric LED displays that show a sequence of messages indicating the state of the card.



### Note

It is normal for some displayed messages to appear too briefly in the LED display to be read.

## Troubleshooting the MSC, FP, or LSP Card

If the installed or replaced line card fails to operate or to power up on installation:

- Make sure that the card is seated firmly into the Cisco CRS Series Enhanced 16-Slot Line Card Chassis slot. One easy way to verify physical installation is to see whether the front faceplate of the card is even with the fronts of the other cards installed in the card cage.
- Check whether the ejector levers are latched and that the captive screws are fastened properly. If you are uncertain, unlatch the levers, loosen the screws, and attempt to reseat the card.
- Examine the Cisco CRS Series Enhanced 16-Slot Line Card Chassis alarm module to see if there are any active alarm conditions. (See *Cisco CRS Series Enhanced 16-Slot Line Card Chassis System Description* for information on the alarm module.)
- Examine the Cisco CRS Series Enhanced 16-Slot Line Card Chassis power shelves to see whether the chassis, as a whole, is receiving power.

Use the Status LED, located on the line card faceplate, to verify the correct installation of the line card:

- When the card is properly installed, the Status LED turns green. If this LED is off, verify that the card is installed correctly.
- If a failure occurs during the board boot sequence, the two four-digit alphanumeric LED displays indicate the current boot phase to assist you in debugging the board failure.

## Installing a PLIM

This section contains the following procedures:


**Note**

Some PLIMs contain Class 1 lasers, while others contain Class 1M lasers; for details of your PLIM, see Cisco CRS Series Enhanced 16-Slot Line Card Chassis System Description.


**Warning**

Class 1 Laser Product. Statement 113


**Warning**

Because invisible radiation may be emitted from the aperture of the port when no fiber cable is connected, avoid exposure to radiation and do not stare into open apertures. Statement 125


**Caution**

Class 1M laser radiation when open. Do not view directly with optical instruments. Statement 281


**Warning**

For diverging beams, viewing the laser output with certain optical instruments within a distance of 100 mm may pose an eye hazard. For collimated beams, viewing the laser output with certain optical instruments designed for use at a distance may pose an eye hazard. Statement 282


**Warning**

Laser radiation. Do not view directly with optical instruments. Class 1M laser product. Statement 283

## Installing a PLIM

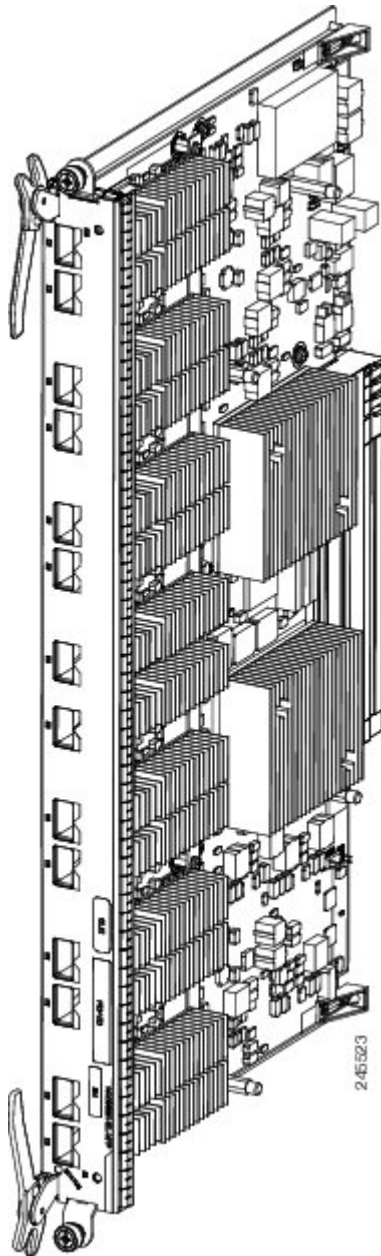
This section describes how to install a PLIM in the Cisco CRS Series Enhanced 16-Slot Line Card Chassis. For more detailed information on PLIMs, see Cisco CRS Series Enhanced 16-Slot Line Card Chassis System Description.


**Caution**

MSC-140G, FP-140, and LSP line cards should only be paired with 20-port and 14-port 10-GE XFP PLIMs and 1-port 100-GE CFP PLIMs. The MSC-40 line card should not be paired with 20-port and 14-port 10-GE XFP PLIMs or 1-port 100-GE CFP PLIMs. The MSC-40 line card can be paired with all previous PLIMs. See the release notes for details.

A PLIM is paired with a line card through the midplane of the chassis. A PLIM provides the ability to choose several interfaces (for example, Packet-over-SONET [PoS]). This figure shows a typical PLIM (in this case, a 14-port 10-GE XFP PLIM).

**Figure 91: Typical PLIM - 14-Port 10-GE XFP PLIM**



You can install a PLIM in any slot not occupied by an RP or Cisco CRS Series Enhanced 16-Slot Line Card Chassis fan controller card. If you install a new line card or PLIM, remove the impedance carrier card from the available slot.



**Caution**

The system can indicate a hardware failure if you do not follow proper procedures. Remove or install only one PLIM at a time. Allow at least 15 seconds for the system to complete the preceding tasks before removing or installing another PLIM.

## Prerequisites

Before performing this task, open the front (PLIM) side cosmetic doors, if installed.

## Required Tools and Equipment

You need the following tools and part to perform this task:

- ESD-preventive wrist strap
- Number 2 Phillips screwdriver or number 2 common (flat head) screwdriver
- PLIM

## Steps

To install a PLIM, see the below figure and perform the following steps:

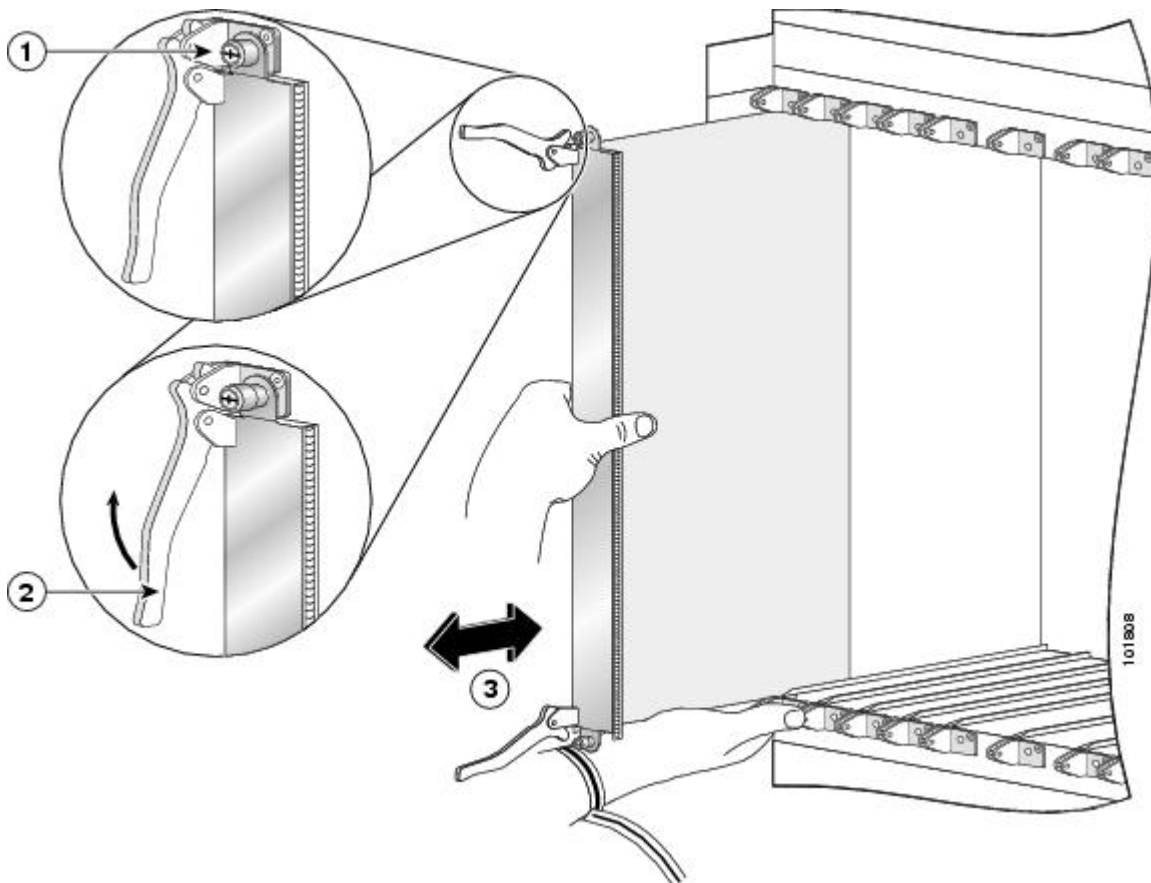
### SUMMARY STEPS

1. Attach the ESD-preventive wrist strap to your wrist and connect its leash to one of the ESD connection sockets: on the front (PLIM) side of the chassis there is one ESD connection socket right above the fan controllers. On the rear (MSC) side of the chassis there are two ESD connection sockets right above the cable management tray in the center of the chassis (left and right). You can also connect the ESD-preventive wrist strap leash to any bare metal surface on the chassis.
2. Remove the PLIM from its antistatic packaging.
3. Remove the PLIM impedance carrier from the slot you need to fill and set it aside.
4. Grasp the card carrier handle with one hand and place your other hand under the carrier to support and guide it into the correct slot (see below figure). Slide the card halfway into the far left slot. Avoid touching the card circuitry or any connectors.
5. Pivot both card ejector levers so that the openings on the card ejector cams at the top and bottom of the card pass over the tabs on each side of the card cage slot.
6. Continue sliding the card into the card cage slot until the openings on the card ejector cams engage the tabs on each side of the card cage slot.
7. To seat the card in the midplane connector, grasp both card ejector levers and pivot them inward toward the handle in the card carrier until they are flush against the front edge of the card carrier.
8. Tighten the captive screws on the PLIM.
9. Install the optical modules, if applicable.
10. Install the PLIM cable management bracket.
11. Install the interface cables.

## DETAILED STEPS

- Step 1** Attach the ESD-preventive wrist strap to your wrist and connect its leash to one of the ESD connection sockets: on the front (PLIM) side of the chassis there is one ESD connection socket right above the fan controllers. On the rear (MSC) side of the chassis there are two ESD connection sockets right above the cable management tray in the center of the chassis (left and right). You can also connect the ESD-preventive wrist strap leash to any bare metal surface on the chassis.
- Step 2** Remove the PLIM from its antistatic packaging.
- Step 3** Remove the PLIM impedance carrier from the slot you need to fill and set it aside. Remove only one impedance carrier and install one PLIM at a time. Be sure to verify that each PLIM is fully installed and secured before installing another card.
- Step 4** Grasp the card carrier handle with one hand and place your other hand under the carrier to support and guide it into the correct slot (see below figure). Slide the card halfway into the far left slot. Avoid touching the card circuitry or any connectors.
- Note** In the PLIM installation figure below, an Impedance Carrier is shown. Refer to [Figure 93: 14-Port 10-Gigabit Ethernet XFP PLIM front panel](#), on page 166 for an example of an actual PLIM faceplate.

**Figure 92: Installing a PLIM**



1	Captive screw	3	Direction of installation or removal
2	Ejector lever		

- Step 5** Pivot both card ejector levers so that the openings on the card ejector cams at the top and bottom of the card pass over the tabs on each side of the card cage slot.
- Caution** Verify that the openings on the card ejector cams pass over the tabs; otherwise, one or both ejector levers might bind when you attempt to close the ejector levers, thereby damaging or breaking one or both ejector levers.
- Step 6** Continue sliding the card into the card cage slot until the openings on the card ejector cams engage the tabs on each side of the card cage slot.
- Note** Guide pins exist that make initial contact with the backplane connector as you slide a card into its slot. After the guide pins make contact, continue pushing on the card carrier until the card ejector levers begin pivoting forward, toward the handle in the card carrier.
- Step 7** To seat the card in the midplane connector, grasp both card ejector levers and pivot them inward toward the handle in the card carrier until they are flush against the front edge of the card carrier.
- Step 8** Tighten the captive screws on the PLIM.
- Caution** To ensure adequate space for additional PLIMs, MSCs, FPs, or LSPs, always tighten the captive installation screws on each newly installed PLIM *before* you insert any additional PLIM, MSC, FP, or LSP. These screws also prevent accidental removal and provide proper grounding and EMI shielding for the system.
- Step 9** Install the optical modules, if applicable.
- Step 10** Install the PLIM cable management bracket.
- Step 11** Install the interface cables.
- Warning** Because invisible laser radiation may be emitted from the aperture of the port when no cable is connected, avoid exposure to laser radiation and do not stare into open apertures. Statement 70
- Some PLIMs contain Class 1 lasers and some contain Class 1M. See the documentation for the specific PLIM for details.

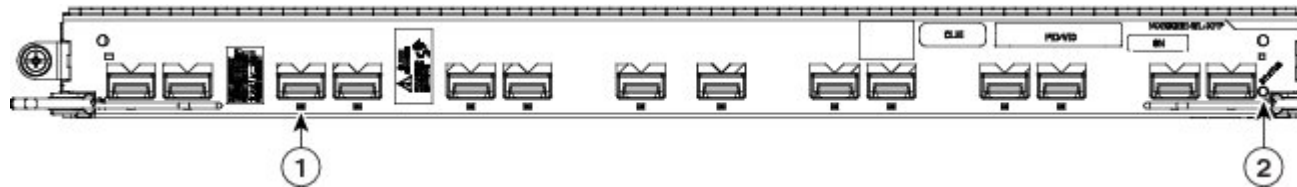
## What to Do Next

After performing this task, place the impedance carrier in an antistatic bag for storage and future use. Close the front (PLIM) side cosmetic doors, if installed, and verify that the card has been installed properly (see the [Verifying the Installation of a PLIM](#), on page 166).

## Verifying the Installation of a PLIM

This section describes how to verify that the PLIM has been properly installed. This figure shows an example of a PLIM front panel (in this case, a 14-port 10-GE XFP PLIM).

**Figure 93: 14-Port 10-Gigabit Ethernet XFP PLIM front panel**



1	Port LED (one per port)	2	Status LED
---	-------------------------	---	------------

## Troubleshooting the PLIM

If a PLIM fails to operate or to power up on installation:

- Make sure that the PLIM is seated firmly in the Cisco CRS Series Enhanced 16-Slot Line Card Chassis slot. One easy way to verify physical installation is to see whether the front faceplate of the PLIM is even with the fronts of the other PLIMs installed in the card cage.
- Check whether the ejector levers are latched and that the captive screws are fastened properly. If you are uncertain, unlatch the levers, loosen the screws, and attempt to reseat the PLIM.
- Examine the alarm module to see if there are any active alarm conditions. (See *Cisco CRS Series Enhanced 16-Slot Line Card Chassis System Description* for information on the alarm module.)
- Examine the power shelves to see whether the chassis, as a whole, is receiving power.

Use the LEDs on the PLIM faceplate to verify the correct installation and operation of the card:

- Status LED—Indicates whether the card is properly seated and operating OK.
  - Green—Card is properly installed and operating OK.
  - Yellow—Problem exists on the card.
  - Off—PLIM is not properly seated or system power is off.

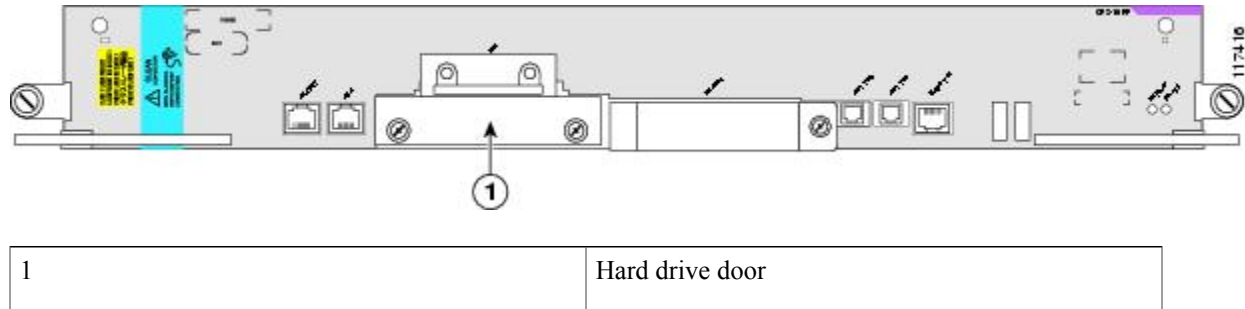
Port Status LED:

- ◦ On—Port is logically active and the laser is on.
- ◦ Off—Port is not active.

## Installing a Card-Based Hard Drive

This section describes how to install a hard drive in an RP or a DRP PLIM. Hard drives are available as an option on both the RP and DRP PLIM and are installed in the same manner. For more detailed information on the hard drives, see the [About Hard Drives and PCMCIA Cards, on page 117](#), or *Cisco CRS Series Enhanced 16-Slot Line Card Chassis System Description*. This figure shows the hard drive location on the RP card. (The hard drive for the DRP PLIM is in a similar location.)

**Figure 94: RP Card Hard Drive Location**



### Prerequisites

Before performing this task, open the cosmetic doors, if installed.

### Required Tools and Equipment

You need the following tools and part to perform this task:

- ESD-preventive strap
- Number 2 Phillips screwdriver or number 2 common (flat head) screwdriver
- Hard drive

### Steps

To install a hard drive, perform the following steps:

## SUMMARY STEPS

1. Attach the ESD-preventive wrist strap to your wrist and connect its leash to one of the ESD connection sockets: on the front (PLIM) side of the chassis there is one ESD connection socket right above the fan controllers. On the rear (MSC) side of the chassis there are two ESD connection sockets right above the cable management tray in the center of the chassis (left and right). You can also connect the ESD-preventive wrist strap leash to any bare metal surface on the chassis.
2. Use the number 2 Phillips screwdriver or number 2 common (flat head) screwdriver to loosen the captive screws at the left and right of the hard drive door on the faceplate of the card. If needed, use a number 2 Phillips screwdriver or number 2 common (flat head) screwdriver on the captive screws.
3. Remove the hard drive door and set it carefully aside.
4. Carefully align the hard drive sled (attached to the hard drive), and slowly insert it into the hard drive slot.
5. After the hard drive is in the slot, firmly press it all the way in so that it is properly seated. (When the hard drive is firmly seated, the release button on the card pops out slightly.)
6. Replace the hard drive door to keep dust out, and tighten the captive screws.

## DETAILED STEPS

- 
- Step 1** Attach the ESD-preventive wrist strap to your wrist and connect its leash to one of the ESD connection sockets: on the front (PLIM) side of the chassis there is one ESD connection socket right above the fan controllers. On the rear (MSC) side of the chassis there are two ESD connection sockets right above the cable management tray in the center of the chassis (left and right). You can also connect the ESD-preventive wrist strap leash to any bare metal surface on the chassis.
- Step 2** Use the number 2 Phillips screwdriver or number 2 common (flat head) screwdriver to loosen the captive screws at the left and right of the hard drive door on the faceplate of the card. If needed, use a number 2 Phillips screwdriver or number 2 common (flat head) screwdriver on the captive screws.
- Step 3** Remove the hard drive door and set it carefully aside.
- Step 4** Carefully align the hard drive sled (attached to the hard drive), and slowly insert it into the hard drive slot.
- Step 5** After the hard drive is in the slot, firmly press it all the way in so that it is properly seated. (When the hard drive is firmly seated, the release button on the card pops out slightly.)
- Step 6** Replace the hard drive door to keep dust out, and tighten the captive screws.
- 

## What to Do Next

After performing this task, replace any cosmetic cover plates.

After installing the hard disk, use the **proc restart hd\_drv** and **proc mandatory on hd\_drv** commands to reduce the chances of data corruption.

## Installing a PCMCIA Card

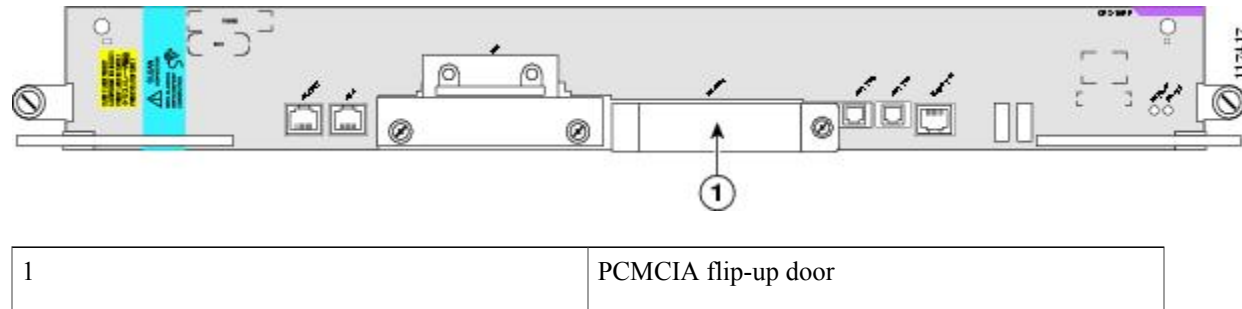
This section describes how to install a PCMCIA card in an RP or a DRP card PCMCIA slot. For more detailed information on PCMCIA cards, see the [About Hard Drives and PCMCIA Cards](#), on page 117, or Cisco CRS

Series Enhanced 16-Slot Line Card Chassis System Description. This figure shows you the location of the PCMCIA door in the RP card faceplate. (The PCMCIA cards for the DRP are in a similar location.)

**Note**

Only the original route processor (RP) card uses a PCMCIA card. The performance route processor (PRP) card has a USB connector for using a flash drive.

**Figure 95: RP Card PCMCIA Slot Door**



## Prerequisites

If you are replacing a PCMCIA card, see the [Removing an RP PCMCIA Card](#), on page 191 for information on how to remove the PCMCIA card from the PCMCIA card slot.

Before performing this task, open the cosmetic doors, if installed.

## Required Tools and Equipment

You need the following tools and part to perform this task:

- ESD-preventive strap
- Number 2 Phillips screwdriver or number 2 common (flat head) screwdriver
- PCMCIA card

## Steps

To install a PCMCIA card, perform the following steps:

**SUMMARY STEPS**

1. Attach the ESD-preventive wrist strap to your wrist and connect its leash to one of the ESD connection sockets: on the front (PLIM) side of the chassis there is one ESD connection socket right above the fan controllers. On the rear (MSC) side of the chassis there are two ESD connection sockets right above the cable management tray in the center of the chassis (left and right). You can also connect the ESD-preventive wrist strap leash to any bare metal surface on the chassis.
2. Using the number 2 Phillips screwdriver or number 2 common (flat head) screwdriver, loosen the captive screw at the bottom of the PCMCIA slot door on the faceplate of the card.
3. While lifting the hinged PCMCIA slot door up, carefully insert the new PCMCIA flash card into the left slot of the PCMCIA card cage. When the card is fully inserted, the release button pops up. (If the button fails to pop up, you may not have the card in right side up; turn the card over and try again.)
4. Close the door to keep dust out, and tighten the captive screw with the number 2 Phillips screwdriver or number 2 common (flat head) screwdriver.

**DETAILED STEPS**

- 
- Step 1** Attach the ESD-preventive wrist strap to your wrist and connect its leash to one of the ESD connection sockets: on the front (PLIM) side of the chassis there is one ESD connection socket right above the fan controllers. On the rear (MSC) side of the chassis there are two ESD connection sockets right above the cable management tray in the center of the chassis (left and right). You can also connect the ESD-preventive wrist strap leash to any bare metal surface on the chassis.
- Step 2** Using the number 2 Phillips screwdriver or number 2 common (flat head) screwdriver, loosen the captive screw at the bottom of the PCMCIA slot door on the faceplate of the card.
- Step 3** While lifting the hinged PCMCIA slot door up, carefully insert the new PCMCIA flash card into the left slot of the PCMCIA card cage. When the card is fully inserted, the release button pops up. (If the button fails to pop up, you may not have the card in right side up; turn the card over and try again.)
- Step 4** Close the door to keep dust out, and tighten the captive screw with the number 2 Phillips screwdriver or number 2 common (flat head) screwdriver.
- 

**What to Do Next**

After performing this task, close the cosmetic doors, if installed.

**Installing Optical Modules**

Refer to the *Cisco CRS Carrier Routing System Ethernet Physical Layer Interface Module Installation Note* for information on how to install SFP, XFP, and other modules for your PLIM.

**Warning**

Because invisible laser radiation may be emitted from the aperture of the port when no cable is connected, avoid exposure to laser radiation and do not stare into open apertures. Statement 70

---

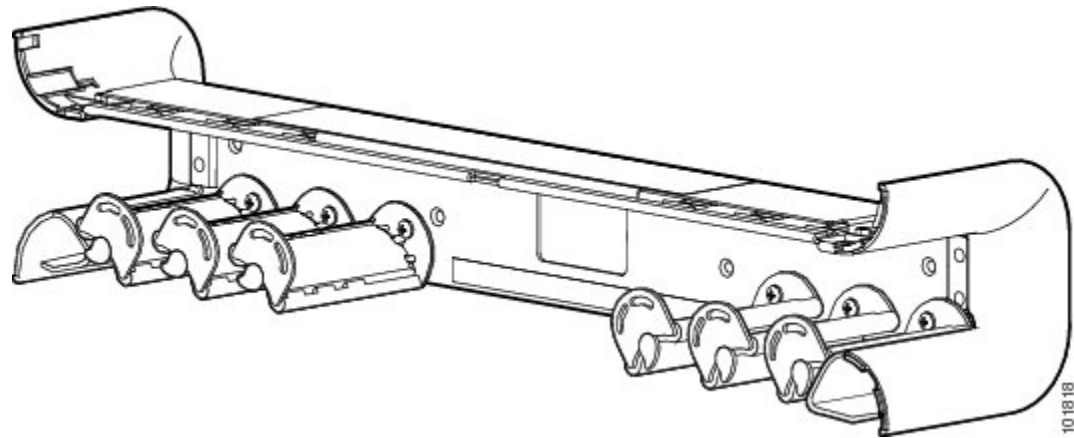


## Installing a Cable Management Bracket

This section describes how to install a cable management bracket in the Cisco CRS Series Enhanced 16-Slot Line Card Chassis.

The horizontal cable management brackets provide cable management capabilities for the MSCs and PLIMs on the Cisco CRS Series Enhanced 16-Slot Line Card Chassis. This figure shows a midchassis cable management bracket. The midchassis cable management bracket is installed on the front (PLIM) side of the chassis.

**Figure 96: Cable Management Bracket**



### Prerequisites

Before performing this task, open the cosmetic doors, if installed, and be sure that there are no cables impeding your access to the area of the chassis on which you wish to install the bracket.

### Required Tools and Equipment

You need the following tools and part to perform this task:

- ESD-preventive wrist strap
- Number 2 Phillips screwdriver or number 2 common (flat head) screwdriver
- Cable management bracket (800-23374-03)

### Steps

To install a cable management bracket, perform the following steps:

## SUMMARY STEPS

1. Attach the ESD-preventive wrist strap to your wrist and connect its leash to one of the ESD connection sockets: on the front (PLIM) side of the chassis there is one ESD connection socket right above the fan controllers. On the rear (MSC) side of the chassis there are two ESD connection sockets right above the cable management tray in the center of the chassis (left and right). You can also connect the ESD-preventive wrist strap leash to any bare metal surface on the chassis.
2. Position the cable management bracket on the chassis.
3. Insert and tighten the four screws used to secure the bracket to the chassis.

## DETAILED STEPS

- 
- Step 1** Attach the ESD-preventive wrist strap to your wrist and connect its leash to one of the ESD connection sockets: on the front (PLIM) side of the chassis there is one ESD connection socket right above the fan controllers. On the rear (MSC) side of the chassis there are two ESD connection sockets right above the cable management tray in the center of the chassis (left and right). You can also connect the ESD-preventive wrist strap leash to any bare metal surface on the chassis.
- Step 2** Position the cable management bracket on the chassis.
- Step 3** Insert and tighten the four screws used to secure the bracket to the chassis.
- 

## What to Do Next

Use the cable management bracket to organize the cables. Close the cosmetic doors, if installed.



## Removing Chassis Components

This chapter provides instructions on how to remove components from the Cisco CRS Enhanced 16-Slot Line Card Chassis.

This chapter presents the following topics:

- [Removing Line Cards, PLIMs and Associated Components, page 173](#)
- [Removing the Rear \(MSC\) Side Cosmetic Components, page 195](#)
- [Removing the Front \(PLIM\) Side Cosmetic Components, page 203](#)
- [Replacing Air Circulation Components, page 212](#)
- [Removing Power Components, page 218](#)
- [Converting from One Power System to the Other, page 242](#)

### Removing Line Cards, PLIMs and Associated Components

This section provides instructions on how to remove the Cisco CRS Series Enhanced 16-Slot Line Card Chassis (LCC) cards, physical layer interface modules (PLIMs), and any associated components.

For general information about installing and removing cards, PLIMs, and associated components, see the [About Installing and Removing Cards and Associated Components, on page 109](#).

For information on installing and removing the slot covers and impedance carriers, see the [Installing or Removing a Slot Cover, on page 118](#) and the [Installing or Removing an Impedance Carrier, on page 122](#).

This section presents the following topics:

#### Removing a Switch Fabric Card

This section describes how to remove a switch fabric card (SFC) from the Cisco CRS Series Enhanced 16-Slot Line Card Chassis. For more detailed information on the different types of switch fabric cards available and details on the cards themselves, see Cisco CRS Series Enhanced 16-Slot Line Card Chassis System Description.



---

**Note** Some switch fabric cards (SFCs) contain Class 1 lasers, while others contain Class 1M lasers; for details on the specifics of your card, see Cisco CRS Series Enhanced 16-Slot Line Card Chassis System Description.

---



---

**Danger** Class 1 Laser Product. Statement 113

---



---

**Danger** Because invisible radiation may be emitted from the aperture of the port when no fiber cable is connected, avoid exposure to radiation and do not stare into open apertures. Statement 125

---



---

**Caution** Class 1M laser radiation when open. Do not view directly with optical instruments. Statement 281

---



---

**Danger** For diverging beams, viewing the laser output with certain optical instruments within a distance of 100 mm may pose an eye hazard. For collimated beams, viewing the laser output with certain optical instruments designed for use at a distance may pose an eye hazard. Statement 282

---



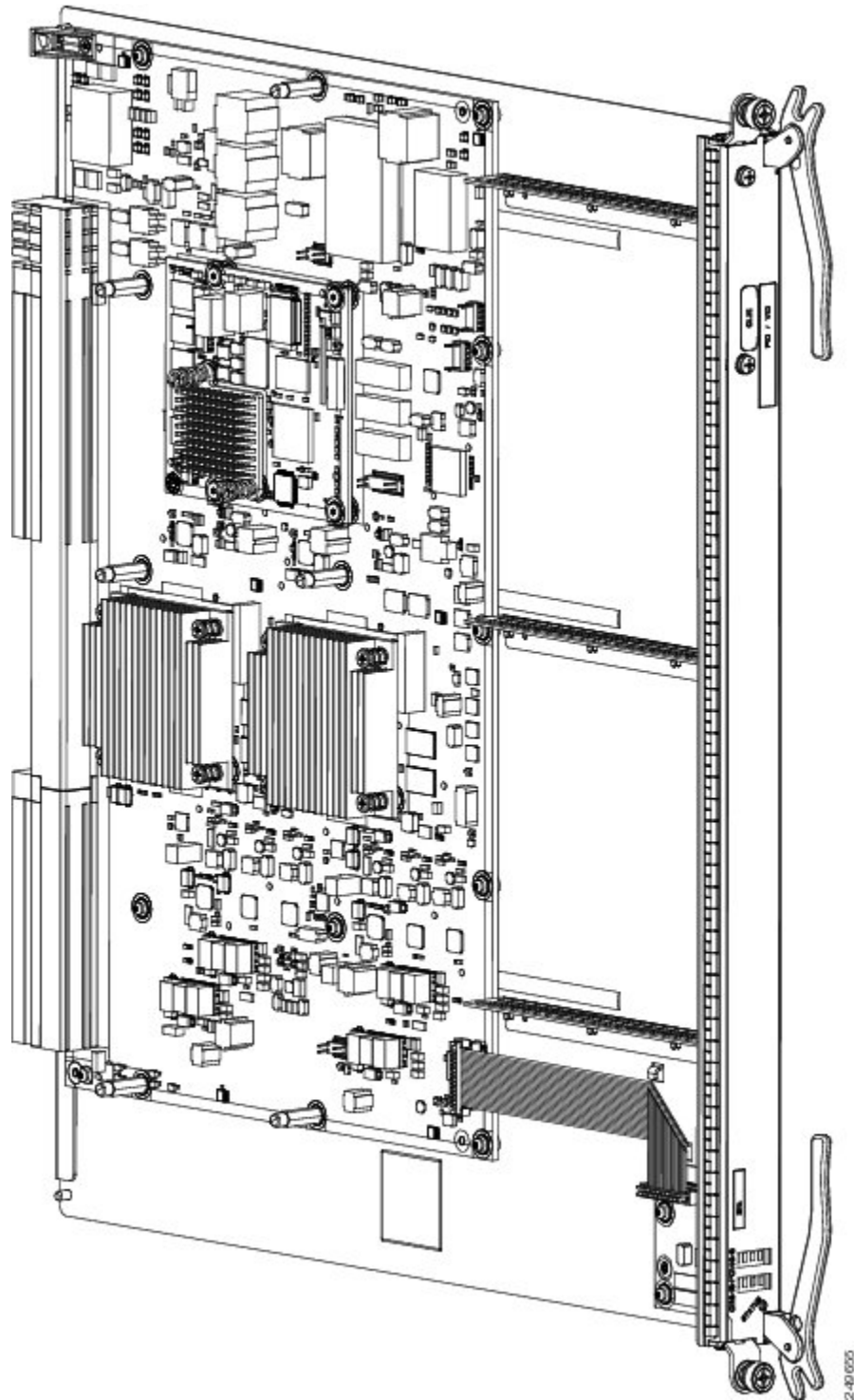
---

**Danger** Laser radiation. Do not view directly with optical instruments. Class 1M laser product. Statement 283

---

The following image shows an example of a switch fabric card (in this case, an FQ123-140G SFC).

**Figure 97: FQ123 -140G Switch Fabric Card**



## Prerequisites

Before performing this task, open the front (PLIM) side cosmetic doors, if installed.

## Required Tools and Equipment

You need the following tools to perform this task:

- ESD-preventive wrist strap
- Number 2 Phillips screwdriver or number 2 common (flat head) screwdriver

## Steps

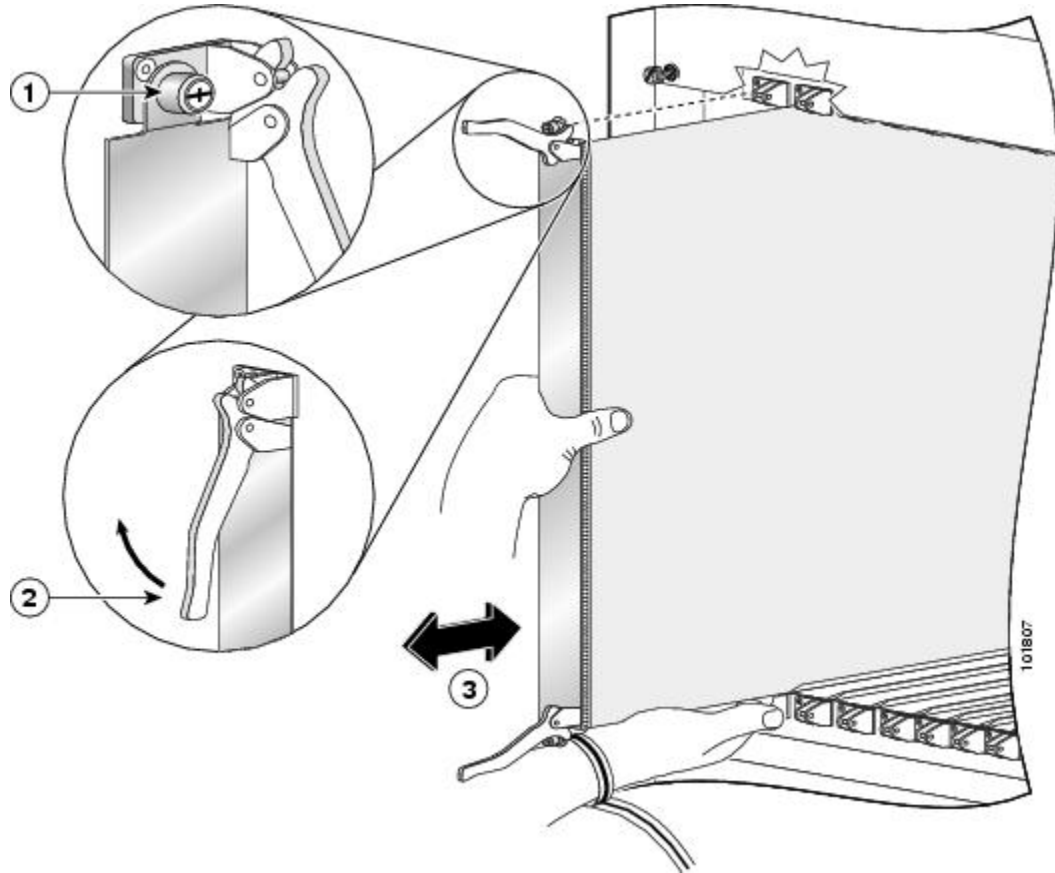
To remove a switch fabric card, see the image below and perform the following steps:



**Note**

In the switch fabric card removal image below, an Impedance Carrier is shown. Refer to image *FQ123-140G Switch Fabric Card* above for an example of the actual switch fabric card.

**Figure 98: Removing a Switch Fabric Card**



1	Captive screw	3	Direction of installation or removal
2	Ejector lever		

## SUMMARY STEPS

1. Attach the ESD-preventive wrist strap to your wrist and connect its leash to one of the ESD connection sockets: on the front (PLIM) side of the chassis there is one ESD connection socket right above the fan controllers. On the rear (MSC) side of the chassis there are two ESD connection sockets right above the cable management tray in the center of the chassis (left and right). You can also connect the ESD-preventive wrist strap leash to any bare metal surface on the chassis.
2. Identify the switch fabric card to be removed from the card cage. Use the number 2 Phillips screwdriver or number 2 common (flat head) screwdriver to turn the two captive screws on the front panel of the card counterclockwise to loosen it from the slot.
3. Grasp the two card ejector levers and simultaneously pivot both ejector levers 90 degrees (70 degrees for a newer switch fabric card) away from the front edge of the card carrier to unseat the card from the midplane connector.
4. Touching only the metal card carrier, slide the card from the slot and place it directly into an antistatic sack or other ESD-preventive container. If you plan to return the defective card to the factory, repackage it in its original shipping container.

## DETAILED STEPS

- 
- Step 1** Attach the ESD-preventive wrist strap to your wrist and connect its leash to one of the ESD connection sockets: on the front (PLIM) side of the chassis there is one ESD connection socket right above the fan controllers. On the rear (MSC) side of the chassis there are two ESD connection sockets right above the cable management tray in the center of the chassis (left and right). You can also connect the ESD-preventive wrist strap leash to any bare metal surface on the chassis.
- Step 2** Identify the switch fabric card to be removed from the card cage. Use the number 2 Phillips screwdriver or number 2 common (flat head) screwdriver to turn the two captive screws on the front panel of the card counterclockwise to loosen it from the slot.
- Step 3** Grasp the two card ejector levers and simultaneously pivot both ejector levers 90 degrees (70 degrees for a newer switch fabric card) away from the front edge of the card carrier to unseat the card from the midplane connector.
- Step 4** Touching only the metal card carrier, slide the card from the slot and place it directly into an antistatic sack or other ESD-preventive container. If you plan to return the defective card to the factory, repackage it in its original shipping container.
- 

## What to Do Next

After performing this task, close the front (PLIM) side cosmetic doors, if installed. If you need to install a new switch fabric card, see the [Installing a Switch Fabric Card](#), on page 146.

## Removing an MSC, FP, or LSP Line Card

This section describes how to remove a line card from the Cisco CRS Series Enhanced 16-Slot Line Card Chassis. For more detailed information on the line cards, see Cisco CRS Series Enhanced 16-Slot Line Card Chassis System Description.



## Prerequisites

Before performing this task, open the cosmetic doors, if installed.

**Caution**

Do not use the faceplate bracket to pull a line card from the slot; you could cause serious damage to the line card.

**Caution**

Remove or install only one modular services card at a time. Allow at least 15 seconds for the router to complete the preceding tasks before removing or installing another modular services card. The router may indicate a hardware failure if you do not follow proper procedures.

## Required Tools and Equipment

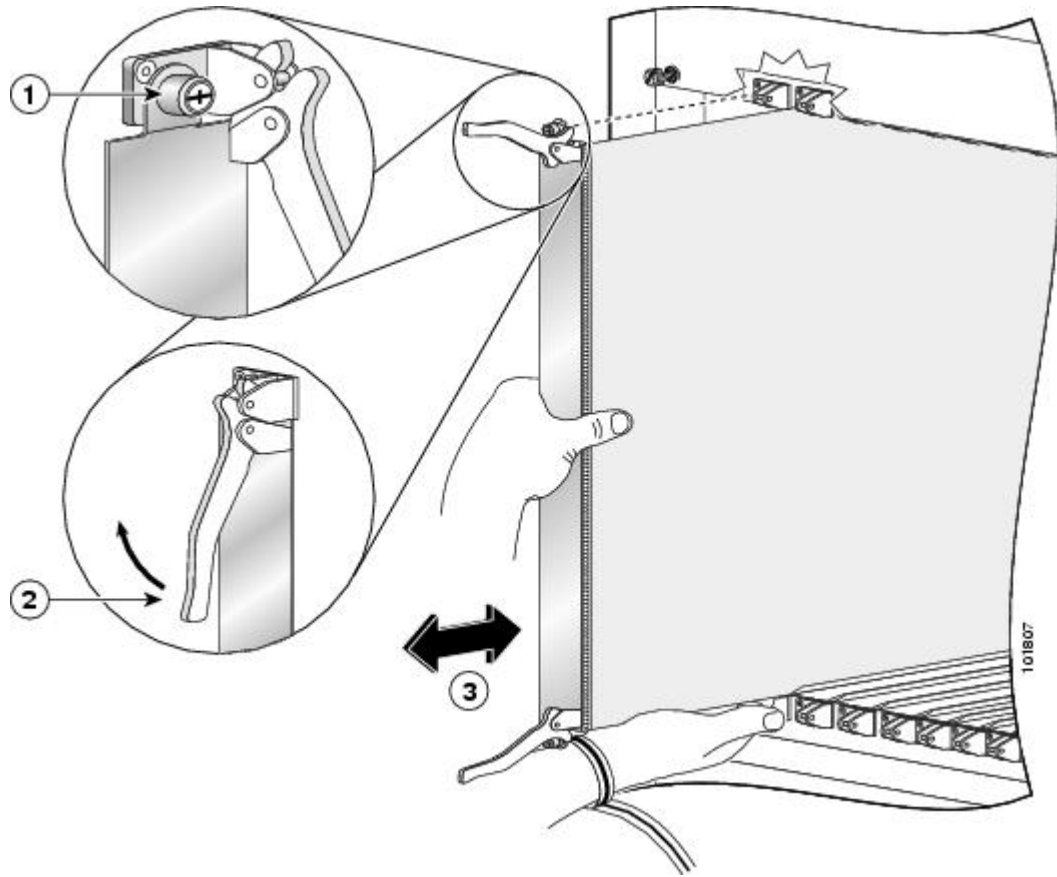
You need the following tools and part to perform this task:

- ESD-preventive strap
- Number 2 Phillips screwdriver or number 2 common (flat head) screwdriver
- MSC Impedance carrier (Cisco product number: CRS-MSC-IMPEDANCE=)

## Steps

To remove a line card, see the image below and perform the following steps:

**Figure 99: Removing a Modular Services Card**



1	Captive screw	3	Direction of installation or removal
2	Ejector lever		

## SUMMARY STEPS

1. Attach the ESD-preventive wrist strap to your wrist and connect its leash to one of the ESD connection sockets: on the front (PLIM) side of the chassis there is one ESD connection socket right above the fan controllers. On the rear (MSC) side of the chassis there are two ESD connection sockets right above the cable management tray in the center of the chassis (left and right). You can also connect the ESD-preventive wrist strap leash to any bare metal surface on the chassis.
2. Use a number 2 Phillips screwdriver or number 2 common (flat head) screwdriver to loosen the captive screw next to each line card ejector lever.
3. Simultaneously pivot the ejector levers away from the faceplate to release the line card from the midplane connectors.
4. Grasp the ejector levers with both hands and gently pull the line card halfway from the slot. Do not use the bracket to pull the line card from the slot.
5. Move one hand under the line card to guide it. Avoid touching the line card printed circuit board, components, or any connector pins.
6. Place the removed line card on an antistatic mat, or immediately place it in an antistatic bag if you plan to return it to the factory.
7. If the line card slot is to remain empty, install an MSC impedance carrier to keep dust out of the chassis and to maintain proper airflow through the line card compartment.
8. Use a number 2 Phillips screwdriver or number 2 common (flat head) screwdriver to tighten the captive screws next to each impedance carrier ejector lever to ensure proper EMI shielding and maintain proper airflow throughout the chassis.

## DETAILED STEPS

- 
- Step 1** Attach the ESD-preventive wrist strap to your wrist and connect its leash to one of the ESD connection sockets: on the front (PLIM) side of the chassis there is one ESD connection socket right above the fan controllers. On the rear (MSC) side of the chassis there are two ESD connection sockets right above the cable management tray in the center of the chassis (left and right). You can also connect the ESD-preventive wrist strap leash to any bare metal surface on the chassis.
- Step 2** Use a number 2 Phillips screwdriver or number 2 common (flat head) screwdriver to loosen the captive screw next to each line card ejector lever.
- Caution** To prevent ESD damage, handle a line card by its ejector levers or the line card carrier edges only. Do not touch any of the electrical components, pins, or circuitry.
- Step 3** Simultaneously pivot the ejector levers away from the faceplate to release the line card from the midplane connectors.
- Step 4** Grasp the ejector levers with both hands and gently pull the line card halfway from the slot. Do not use the bracket to pull the line card from the slot.
- Step 5** Move one hand under the line card to guide it. Avoid touching the line card printed circuit board, components, or any connector pins.
- Step 6** Place the removed line card on an antistatic mat, or immediately place it in an antistatic bag if you plan to return it to the factory.
- Step 7** If the line card slot is to remain empty, install an MSC impedance carrier to keep dust out of the chassis and to maintain proper airflow through the line card compartment.
- Step 8** Use a number 2 Phillips screwdriver or number 2 common (flat head) screwdriver to tighten the captive screws next to each impedance carrier ejector lever to ensure proper EMI shielding and maintain proper airflow throughout the chassis.
-

## What to Do Next

After performing this task, close the rear (MSC) side cosmetic doors, if installed. If you need to install a new MSC, FP, or LSP Line Card, see the [Installing an MSC, FP, or LSP Line Card](#), on page 152.

## Removing a Fan Controller Card

This section describes how to remove a fan controller card from the Cisco CRS Series Enhanced 16-Slot Line Card Chassis. For more detailed information on the Cisco CRS Series Enhanced 16-Slot Line Card Chassis fan controller card, see Cisco CRS Series Enhanced 16-Slot Line Card Chassis System Description.

Two Cisco CRS Series Enhanced 16-Slot Line Card Chassis fan controller cards, exist in every Cisco CRS Series Enhanced 16-Slot Line Card Chassis.

## Prerequisites

Before performing this task, open the front (PLIM) side cosmetic doors, if installed.

## Required Tools and Equipment

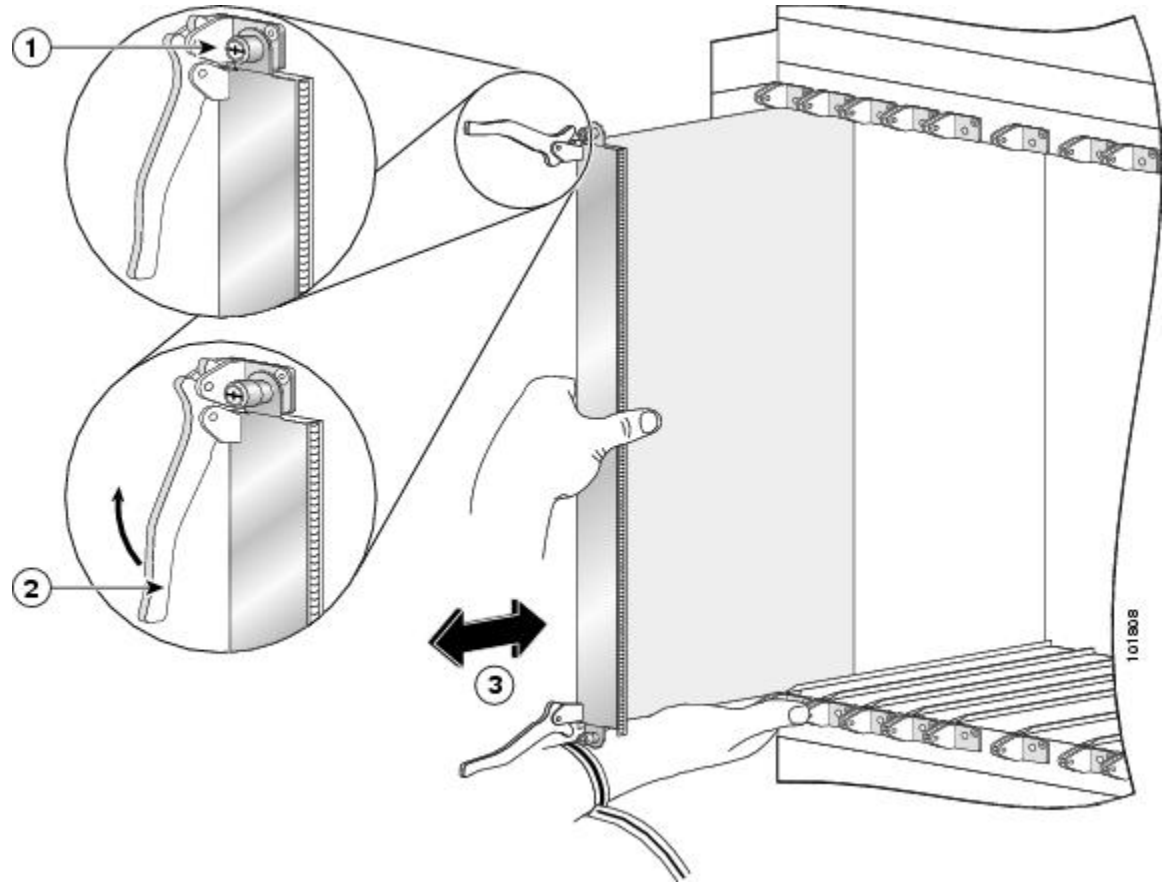
You need the following tools to perform this task:

- ESD-preventive wrist strap
- Number 2 Phillips screwdriver or number 2 common (flat head) screwdriver

## Steps

To remove a Cisco CRS Series Enhanced 16-Slot Line Card Chassis fan controller card, see the image below and perform the following steps:

**Figure 100: Removing a Cisco CRS Series Enhanced 16-Slot Line Card Chassis Fan Controller Card**



1	Captive screw	3	Direction of installation or removal
2	Ejector lever		

## SUMMARY STEPS

1. Attach the ESD-preventive wrist strap to your wrist and connect its leash to one of the ESD connection sockets: on the front (PLIM) side of the chassis there is one ESD connection socket right above the fan controllers. On the rear (MSC) side of the chassis there are two ESD connection sockets right above the cable management tray in the center of the chassis (left and right). You can also connect the ESD-preventive wrist strap leash to any bare metal surface on the chassis.
2. Identify the Cisco CRS Series Enhanced 16-Slot Line Card Chassis fan controller card to be removed from the card cage. Use the number 2 Phillips screwdriver or number 2 common (flat head) screwdriver to turn the two captive screws on the front panel of the card counterclockwise to loosen it from the slot.
3. Grasp the two card ejector levers and simultaneously pivot both ejector levers 90 degrees (70 degrees for a new Cisco CRS Series Enhanced 16-Slot Line Card Chassis fan controller card) away from the front edge of the card carrier to unseat the card from the midplane connector.
4. Touching only the metal card carrier, slide the card from the slot and place it directly into an antistatic sack or other ESD-preventive container. If you plan to return the defective card to the factory, repackage it in its original packaging.

## DETAILED STEPS

- 
- Step 1** Attach the ESD-preventive wrist strap to your wrist and connect its leash to one of the ESD connection sockets: on the front (PLIM) side of the chassis there is one ESD connection socket right above the fan controllers. On the rear (MSC) side of the chassis there are two ESD connection sockets right above the cable management tray in the center of the chassis (left and right). You can also connect the ESD-preventive wrist strap leash to any bare metal surface on the chassis.
- Step 2** Identify the Cisco CRS Series Enhanced 16-Slot Line Card Chassis fan controller card to be removed from the card cage. Use the number 2 Phillips screwdriver or number 2 common (flat head) screwdriver to turn the two captive screws on the front panel of the card counterclockwise to loosen it from the slot.
- Step 3** Grasp the two card ejector levers and simultaneously pivot both ejector levers 90 degrees (70 degrees for a new Cisco CRS Series Enhanced 16-Slot Line Card Chassis fan controller card) away from the front edge of the card carrier to unseat the card from the midplane connector.
- Step 4** Touching only the metal card carrier, slide the card from the slot and place it directly into an antistatic sack or other ESD-preventive container. If you plan to return the defective card to the factory, repackage it in its original packaging.
- 

## What to Do Next

After performing this task, close the front (PLIM) side cosmetic doors. If you need to install a new fan controller card, see the [Installing a Cisco CRS Series Enhanced 16-Slot Line Card Chassis Fan Controller Card](#), on page 140.

## Removing an RP, PRP, or DRP Card

This section describes how to remove a route processor (RP), performance route processor (PRP), or distributed route processor (DRP) card from the Cisco CRS Series Enhanced 16-Slot Line Card Chassis. For more detailed

information on the route processor card, see the [Installing an RP, PRP, or DRP Card](#), on page 130 or Cisco CRS Series Enhanced 16-Slot Line Card Chassis System Description.

Every Cisco CRS Series Enhanced 16-Slot Line Card Chassis contains two route processor cards in dedicated slots on the PLIM side of the chassis.

**Danger**

---

Class 1 Laser Product. Statement 113

---

**Danger**

---

Because invisible radiation may be emitted from the aperture of the port when no fiber cable is connected, avoid exposure to radiation and do not stare into open apertures. Statement 125

---

## Prerequisites

Because chassis operation may be impacted by the removal of an RP or PRP card, perform these tasks only if one of the following conditions exists:

- When you are certain that the RP card in the chassis is operational and, if not already the Active RP, ready to assume control (this happens automatically)
- When the chassis is undergoing scheduled maintenance
- When the Cisco CRS Series Enhanced 16-Slot Line Card Chassis is powered down

Failure to follow these guidelines can result in interruptions in data communications and network connectivity. Before performing this task, open the cosmetic doors (if installed).

## Required Tools and Equipment

You need the following tools to perform this task:

- ESD-preventive wrist strap
- Number 2 Phillips screwdriver or number 2 common (flat head) screwdriver

## Steps

To remove an RP, PRP, or DRP card, perform the following steps:

## SUMMARY STEPS

1. Attach the ESD-preventive wrist strap to your wrist and connect its leash to one of the ESD connection sockets: on the front (PLIM) side of the chassis there is one ESD connection socket right above the fan controllers. On the rear (MSC) side of the chassis there are two ESD connection sockets right above the cable management tray in the center of the chassis (left and right). You can also connect the ESD-preventive wrist strap leash to any bare metal surface on the chassis.
2. Identify the card to be removed from the card cage. Remove any cables connected to the front panel of the card.
3. PRP cards only—Before removing a PRP card, you must first push the OIR button (using a pointed object such as a pen), which causes the blue OIR Ready LED to start blinking. When the board is ready for removal, the blue LED glows solidly.
4. Use the number 2 Phillips screwdriver or number 2 common (flat head) screwdriver to turn the two captive screws on the front panel of the card counterclockwise to loosen the card from the slot.
5. Grasp the two card ejector levers and simultaneously pivot both ejector levers 90 degrees away from the front edge of the card carrier to unseat the card from the backplane connector.
6. Touching only the metal card carrier, slide the card from the slot and place it directly into an antistatic sack or other ESD-preventive container. If you plan to return the defective card to the factory, repackage it in the shipping container you received with the replacement card.

## DETAILED STEPS

- 
- Step 1** Attach the ESD-preventive wrist strap to your wrist and connect its leash to one of the ESD connection sockets: on the front (PLIM) side of the chassis there is one ESD connection socket right above the fan controllers. On the rear (MSC) side of the chassis there are two ESD connection sockets right above the cable management tray in the center of the chassis (left and right). You can also connect the ESD-preventive wrist strap leash to any bare metal surface on the chassis.
- Step 2** Identify the card to be removed from the card cage. Remove any cables connected to the front panel of the card.
- Step 3** PRP cards only—Before removing a PRP card, you must first push the OIR button (using a pointed object such as a pen), which causes the blue OIR Ready LED to start blinking. When the board is ready for removal, the blue LED glows solidly.
- Step 4** Use the number 2 Phillips screwdriver or number 2 common (flat head) screwdriver to turn the two captive screws on the front panel of the card counterclockwise to loosen the card from the slot.
- Step 5** Grasp the two card ejector levers and simultaneously pivot both ejector levers 90 degrees away from the front edge of the card carrier to unseat the card from the backplane connector.
- Step 6** Touching only the metal card carrier, slide the card from the slot and place it directly into an antistatic sack or other ESD-preventive container. If you plan to return the defective card to the factory, repackage it in the shipping container you received with the replacement card.
- 

## What to Do Next

After performing this task, close the front (PLIM) side cosmetic doors (if installed). If you need to install a new RP, DRP, or PRP card, see the [Installing an RP, PRP, or DRP Card](#), on page 130.



## Removing a PLIM

This section describes how to remove a PLIM from the Cisco CRS Series Enhanced 16-Slot Line Card Chassis.



**Note** Some PLIMs contain Class 1 lasers, while others contain Class 1M lasers; for details of your PLIM, see Cisco CRS Series Enhanced 16-Slot Line Card Chassis System Description.



**Danger** Class 1 Laser Product. Statement 113



**Danger** Because invisible radiation may be emitted from the aperture of the port when no fiber cable is connected, avoid exposure to radiation and do not stare into open apertures. Statement 125



**Caution** Class 1M laser radiation when open. Do not view directly with optical instruments. Statement 281



**Danger** For diverging beams, viewing the laser output with certain optical instruments within a distance of 100 mm may pose an eye hazard. For collimated beams, viewing the laser output with certain optical instruments designed for use at a distance may pose an eye hazard. Statement 282



**Danger** Laser radiation. Do not view directly with optical instruments. Class 1M laser product. Statement 283



**Caution** The following warning applies to removing very-short-reach (VSR) PLIMs: The router may indicate a hardware failure if you do not follow proper procedures. Remove or install only one PLIM at a time. Allow at least 15 seconds for the router to complete the preceding tasks before removing or installing another PLIM.

### Prerequisites

Before performing this task, open the front (PLIM) side cosmetic doors (if installed).



**Caution** The system can indicate a hardware failure if you do not follow proper procedures. Remove or install only one PLIM at a time. Allow at least 15 seconds for the system to complete the preceding tasks before removing or installing another PLIM.



**Note**

We strongly recommend that you use the Cisco IOS XR shutdown command before removing a PLIM to prevent anomalies when you reinstall a new or reconfigured PLIM.

### Required Tools and Equipment

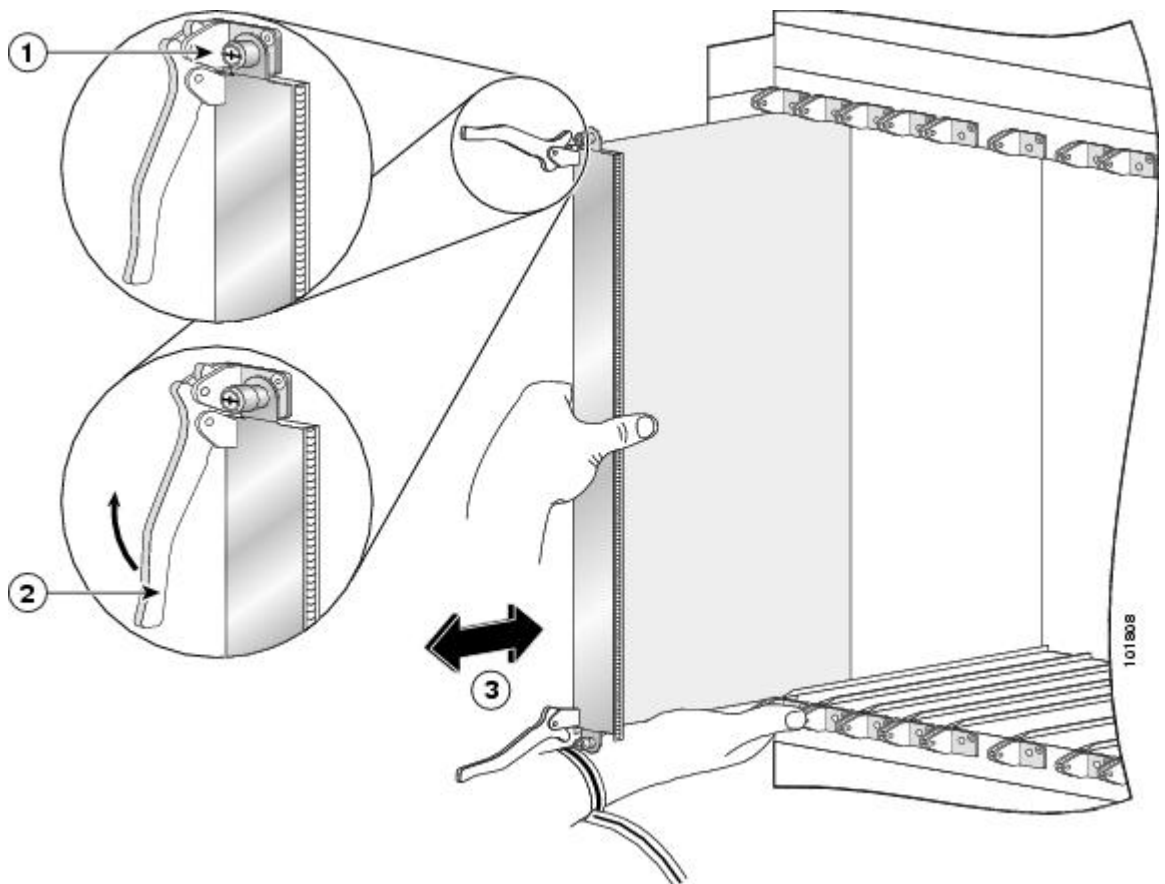
You need the following tools to perform this task:

- ESD-preventive wrist strap
- Number 2 Phillips screwdriver or number 2 common (flat head) screwdriver

### Steps

To remove a PLIM, see the image below and perform the following steps:

**Figure 101: Removing a PLIM**



1	Captive screw	3	Direction of installation or removal
---	---------------	---	--------------------------------------

2	Ejector lever		
---	---------------	--	--

**SUMMARY STEPS**

1. Attach the ESD-preventive wrist strap to your wrist and connect its leash to one of the ESD connection sockets: on the front (PLIM) side of the chassis there is one ESD connection socket right above the fan controllers. On the rear (MSC) side of the chassis there are two ESD connection sockets right above the cable management tray in the center of the chassis (left and right). You can also connect the ESD-preventive wrist strap leash to any bare metal surface on the chassis.
2. Identify the card to be replaced.
3. Use the number 2 Phillips screwdriver or number 2 common (flat head) screwdriver to loosen the two captive screws holding the card in place.
4. Grasp the two card ejector levers and simultaneously pivot both ejector levers 90 degrees (70 degrees for a newer PLIM) away from the front edge of the card carrier to unseat the card from the backplane connector.
5. Touching only the metal card carrier, slide the card from the slot and place it directly into an antistatic sack or other ESD-preventive container.

**DETAILED STEPS**

- 
- Step 1** Attach the ESD-preventive wrist strap to your wrist and connect its leash to one of the ESD connection sockets: on the front (PLIM) side of the chassis there is one ESD connection socket right above the fan controllers. On the rear (MSC) side of the chassis there are two ESD connection sockets right above the cable management tray in the center of the chassis (left and right). You can also connect the ESD-preventive wrist strap leash to any bare metal surface on the chassis.
  - Step 2** Identify the card to be replaced.
  - Step 3** Use the number 2 Phillips screwdriver or number 2 common (flat head) screwdriver to loosen the two captive screws holding the card in place.
  - Step 4** Grasp the two card ejector levers and simultaneously pivot both ejector levers 90 degrees (70 degrees for a newer PLIM) away from the front edge of the card carrier to unseat the card from the backplane connector.
  - Step 5** Touching only the metal card carrier, slide the card from the slot and place it directly into an antistatic sack or other ESD-preventive container.
- 

**What to Do Next**



**Danger**

Because invisible laser radiation may be emitted from the aperture of the port when no cable is connected, avoid exposure to laser radiation and do not stare into open apertures. Statement 70

Some PLIMs contain Class 1 lasers and some contain Class 1M. See the documentation for the specific PLIM for details.

## What to Do Next

After performing this task, close the front (PLIM) side cosmetic doors (if installed). If you need to install a new PLIM, see [Installing a PLIM](#), on page 161.

## Removing a Hard Drive

This section describes how to remove a hard drive from an RP or a DRP PLIM. Hard drives are available as an option on both the RP and DRP PLIM and are removed in the same manner. For more detailed information on the hard drives, see the [About Hard Drives and PCMCIA Cards](#), on page 117, or *Cisco CRS Series Enhanced 16-Slot Line Card Chassis System Description*. [Installing a Card-Based Hard Drive](#), on page 167 shows the hard drive door location on the RP card. (The hard drive for the DRP PLIM is in a similar location.)

## Prerequisites

The hard disk should be powered down prior to removal. This reduces the chances of data corruption. To power down the hard disk prior to removal, use the **proc mandatory off hd\_drv** and **proc shutdown hd\_drv** commands.

Before performing this task, open the front (PLIM) side cosmetic doors (if installed).

## Required Tools and Equipment

You need the following tools to perform this task:

- ESD-preventive strap
- Number 2 Phillips screwdriver or number 2 common (flat head) screwdriver

## Steps

To remove the hard drive, perform the following steps:

## SUMMARY STEPS

1. Attach the ESD-preventive wrist strap to your wrist and connect its leash to one of the ESD connection sockets: on the front (PLIM) side of the chassis there is one ESD connection socket right above the fan controllers. On the rear (MSC) side of the chassis there are two ESD connection sockets right above the cable management tray in the center of the chassis (left and right). You can also connect the ESD-preventive wrist strap leash to any bare metal surface on the chassis.
2. Use the number 2 Phillips screwdriver or number 2 common (flat head) screwdriver to loosen the captive screws at the left and right of the hard drive door on the faceplate of the card. If needed, use a number 2 Phillips screwdriver or number 2 common (flat head) screwdriver on the captive screws.
3. Remove the hard drive door and set it carefully aside.
4. Press the release button to unseat the hard drive sled from the card.
5. Carefully pull the hard drive sled from the card.
6. Place the removed hard drive on an antistatic mat, or immediately place it in an antistatic bag if you plan to return it to the factory.
7. If the hard drive slot is to remain empty, replace the door to keep dust out, and tighten the captive screws.

## DETAILED STEPS

- 
- Step 1** Attach the ESD-preventive wrist strap to your wrist and connect its leash to one of the ESD connection sockets: on the front (PLIM) side of the chassis there is one ESD connection socket right above the fan controllers. On the rear (MSC) side of the chassis there are two ESD connection sockets right above the cable management tray in the center of the chassis (left and right). You can also connect the ESD-preventive wrist strap leash to any bare metal surface on the chassis.
- Step 2** Use the number 2 Phillips screwdriver or number 2 common (flat head) screwdriver to loosen the captive screws at the left and right of the hard drive door on the faceplate of the card. If needed, use a number 2 Phillips screwdriver or number 2 common (flat head) screwdriver on the captive screws.
- Step 3** Remove the hard drive door and set it carefully aside.
- Step 4** Press the release button to unseat the hard drive sled from the card.
- Step 5** Carefully pull the hard drive sled from the card.
- Step 6** Place the removed hard drive on an antistatic mat, or immediately place it in an antistatic bag if you plan to return it to the factory.
- Step 7** If the hard drive slot is to remain empty, replace the door to keep dust out, and tighten the captive screws.
- 

## What to Do Next

Close the front (PLIM) side cosmetic doors (if installed). If you need to install a new hard drive, see the [Installing a Card-Based Hard Drive](#), on page 167.

## Removing an RP PCMCIA Card

This section describes how to install a PCMCIA card in an RP or a DRP card PCMCIA slot. For more detailed information on PCMCIA cards, see the [About Hard Drives and PCMCIA Cards](#), on page 117, or Cisco CRS

Series Enhanced 16-Slot Line Card Chassis System Description. Figure [Figure 95: RP Card PCMCIA Slot Door](#), on page 169 shows you the location of the PCMCIA door in the RP card faceplate. (The PCMCIA cards for the DRP are in a similar location).

## Prerequisites

Before performing this task, open the front (PLIM) side cosmetic doors (if installed).

## Required Tools and Equipment

You need the following tools to perform this task:

- ESD-preventive strap
- Number 2 Phillips screwdriver or number 2 common (flat head) screwdriver

## Steps

To remove the PCMCIA card, perform the following steps:

### SUMMARY STEPS

1. Attach the ESD-preventive wrist strap to your wrist and connect its leash to one of the ESD connection sockets: on the front (PLIM) side of the chassis there is one ESD connection socket right above the fan controllers. On the rear (MSC) side of the chassis there are two ESD connection sockets right above the cable management tray in the center of the chassis (left and right). You can also connect the ESD-preventive wrist strap leash to any bare metal surface on the chassis.
2. Using the number 2 Phillips screwdriver or number 2 common (flat head) screwdriver, loosen the captive screw at the bottom of the PCMCIA slot door on the faceplate of the card.
3. While lifting the hinged PCMCIA slot door up, press the release button for the card slot to disengage the card from the card, and then carefully pull out the far left removable PCMCIA flash card.
4. Place the removed PCMCIA card on an antistatic mat, or immediately place it in an antistatic bag if you plan to return it to the factory.
5. If the PCMCIA card slot is to remain empty, close the door to keep dust out, and tighten the captive screw with the number 2 Phillips screwdriver or number 2 common (flat head) screwdriver. Otherwise, install the new PCMCIA card.

### DETAILED STEPS

- 
- Step 1** Attach the ESD-preventive wrist strap to your wrist and connect its leash to one of the ESD connection sockets: on the front (PLIM) side of the chassis there is one ESD connection socket right above the fan controllers. On the rear (MSC) side of the chassis there are two ESD connection sockets right above the cable management tray in the center of the

chassis (left and right). You can also connect the ESD-preventive wrist strap leash to any bare metal surface on the chassis.

- Step 2** Using the number 2 Phillips screwdriver or number 2 common (flat head) screwdriver, loosen the captive screw at the bottom of the PCMCIA slot door on the faceplate of the card.
- Step 3** While lifting the hinged PCMCIA slot door up, press the release button for the card slot to disengage the card from the card, and then carefully pull out the far left removable PCMCIA flash card.
- Step 4** Place the removed PCMCIA card on an antistatic mat, or immediately place it in an antistatic bag if you plan to return it to the factory.
- Step 5** If the PCMCIA card slot is to remain empty, close the door to keep dust out, and tighten the captive screw with the number 2 Phillips screwdriver or number 2 common (flat head) screwdriver. Otherwise, install the new PCMCIA card.
- 

## What to Do Next

Close the front (PLIM) side cosmetic doors (if installed). If you intend to install a new PCMCIA card, see the [Installing a PCMCIA Card](#), on page 168.

## Removing Optical Modules

Refer to the *Cisco CRS Carrier Routing System Ethernet Physical Layer Interface Module Installation Note* for information on how to install or remove SFP, XFP, and other modules for your PLIM.

**Danger**

Because invisible laser radiation may be emitted from the aperture of the port when no cable is connected, avoid exposure to laser radiation and do not stare into open apertures. Statement 70

---

**Note**

After removing a PLIM, be sure to replace any front (PLIM) side cover plates.

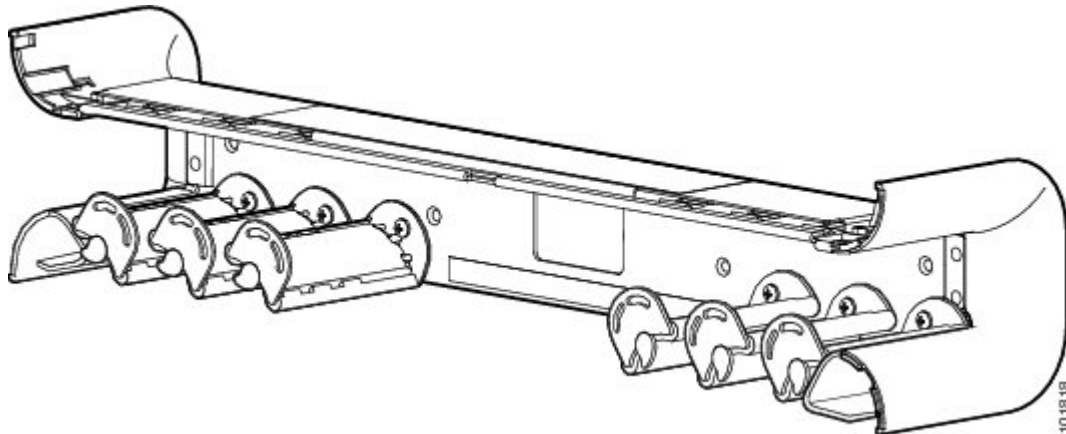
---

## Removing a Cable Management Bracket

This section describes how to remove a cable management bracket in the Cisco CRS Series Enhanced 16-Slot Line Card Chassis.

The horizontal cable management brackets provide cable management capabilities for the MSCs and PLIMs on the Cisco CRS Series Enhanced 16-Slot Line Card Chassis. The following image shows a midchassis cable management bracket. The installed on the front (PLIM) side of the chassis.

**Figure 102: Cable Management Bracket**



## Prerequisites

The cable management bracket arrives pre-installed on the chassis. Before performing this task, open the cosmetic doors (if installed) and remove any cables from the bracket.

## Required Tools and Equipment

You need the following tools to perform this task:

- ESD-preventive wrist strap
- Number 2 Phillips screwdriver or number 2 common (flat head) screwdriver

## Steps

To remove a cable management bracket, perform the following steps:

### SUMMARY STEPS

1. Attach the ESD-preventive wrist strap to your wrist and connect its leash to one of the ESD connection sockets: on the front (PLIM) side of the chassis there is one ESD connection socket right above the fan controllers. On the rear (MSC) side of the chassis there are two ESD connection sockets right above the cable management tray in the center of the chassis (left and right). You can also connect the ESD-preventive wrist strap leash to any bare metal surface on the chassis.
2. Use the number 2 Phillips screwdriver or number 2 common (flat head) screwdriver to loosen and remove the four screws holding the bracket to the chassis.
3. Set the bracket carefully aside.



## DETAILED STEPS

- 
- Step 1** Attach the ESD-preventive wrist strap to your wrist and connect its leash to one of the ESD connection sockets: on the front (PLIM) side of the chassis there is one ESD connection socket right above the fan controllers. On the rear (MSC) side of the chassis there are two ESD connection sockets right above the cable management tray in the center of the chassis (left and right). You can also connect the ESD-preventive wrist strap leash to any bare metal surface on the chassis.
- Step 2** Use the number 2 Phillips screwdriver or number 2 common (flat head) screwdriver to loosen and remove the four screws holding the bracket to the chassis.
- Step 3** Set the bracket carefully aside.
- 

## What to Do Next

You may now install a replacement cable management bracket, if necessary. See the [Installing a Cable Management Bracket, on page 171](#) for more information. Close the cosmetic doors (if installed) after replacing the cable management bracket.

# Removing the Rear (MSC) Side Cosmetic Components

This section describes how to remove the rear (MSC) side exterior cosmetic components from the chassis. This section includes all the steps you need to remove all cosmetic parts from the chassis.

This section contains the following procedures:

If you are not using the vertical cable troughs, see the [Removing the Upper Rear Air Grille and Rear Kick Plate if Vertical Troughs Are Not Used, on page 201](#).

**Note**

---

While it is possible to remove most of the rear cosmetic parts on the fabric chassis separately, some parts (such as a vertical cable trough) require that other parts be removed first.

---

## Prerequisites

Ensure that you have all the original packaging material for the cosmetic components available.

## Required Tools and Equipment

You need the following tool to perform this task:

- 8-in. number 1 Phillips screwdriver—magnetic head preferable

## Steps

To remove the rear (MSC) side cosmetic components, perform the following steps:

### SUMMARY STEPS

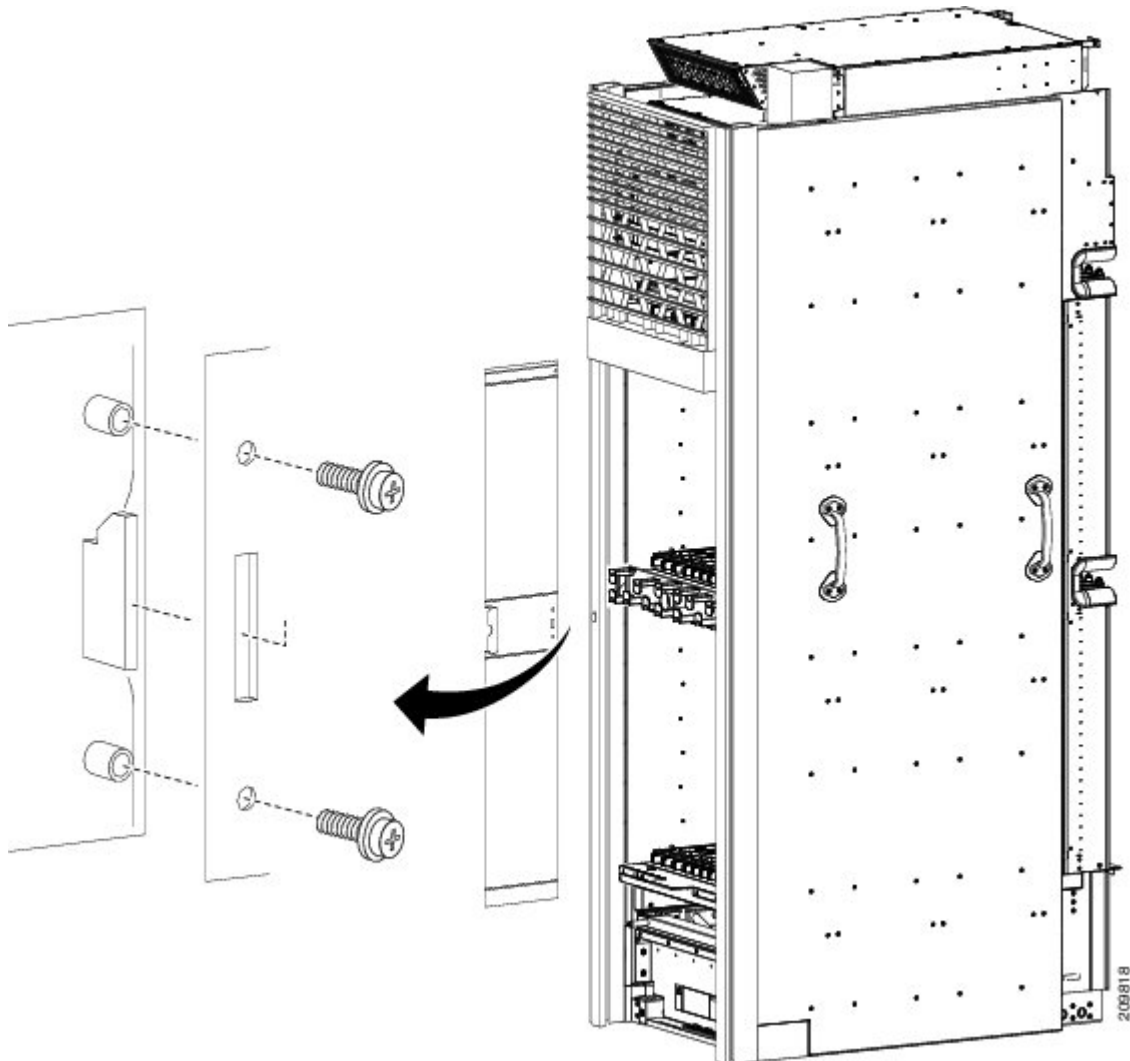
1. (Removing the Rear Doors) Remove the screws from the doors. There are four M4 x 10 screws on each side for the metal sections of the doors and six M4 x 8 screws on each side for the plexiglass section of the door.
2. Lift the doors and set them carefully aside. See the above image.
3. (Removing the Upper Rear Air Grille) Follow these steps if you are using the vertical troughs. To remove the upper rear air grille if the vertical troughs are not used, see the [Removing the Upper Rear Air Grille and Rear Kick Plate if Vertical Troughs Are Not Used](#), on page 201.
4. Release the upper rear air grille from the ball stud retainers.
5. Carefully unhook the hanger brackets from the top of the vertical cable troughs as shown in the following image.
6. (Removing the Rear Kick Plate) Follow these steps if you are using the vertical troughs. To remove the rear kick plate if the vertical troughs are not used, see the [Removing the Upper Rear Air Grille and Rear Kick Plate if Vertical Troughs Are Not Used](#), on page 201.
7. Release the kick plate from the ball stud retainers.
8. Carefully remove the rear kick plate from the tabs on the bottom as shown in the following image.
9. (Removing the Rear Vertical Cable Troughs) Remove the rear vertical cable troughs—one left and one right—from the rear of the chassis as shown in the following image.

### DETAILED STEPS

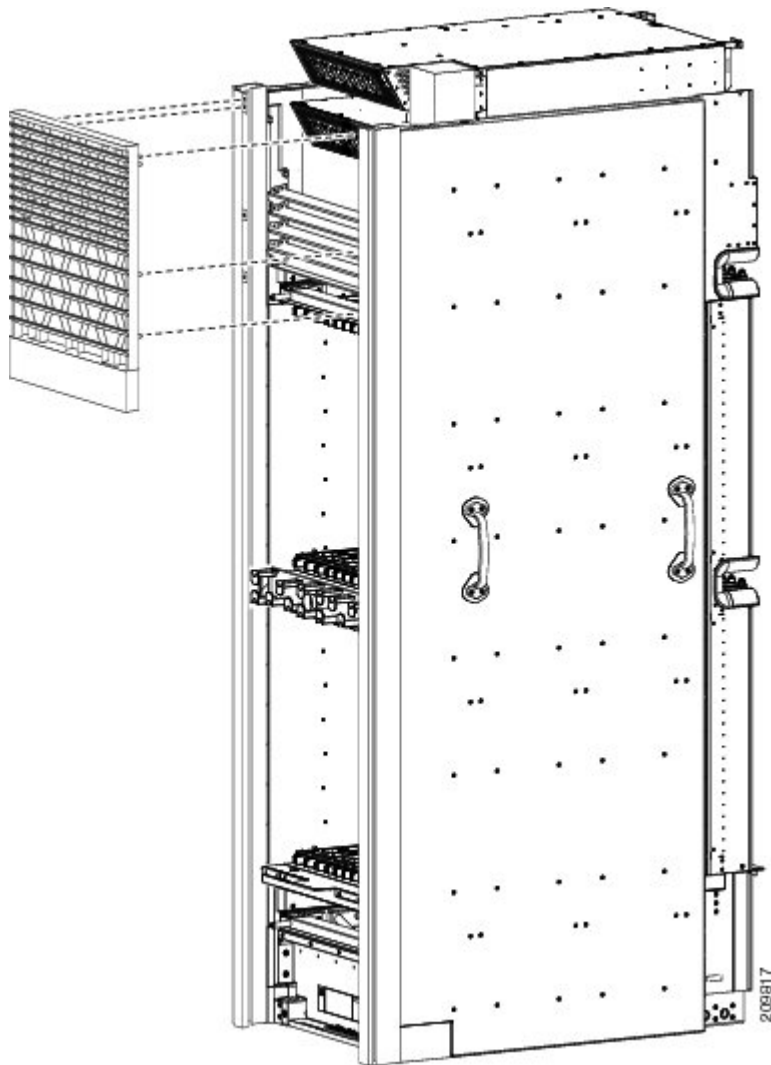
- 
- Step 1** (Removing the Rear Doors) Remove the screws from the doors. There are four M4 x 10 screws on each side for the metal sections of the doors and six M4 x 8 screws on each side for the plexiglass section of the door.

**Note** To ensure that the door is well supported during removal, remove the screws in the upper and lower metal sections last.

**Figure 103: Removing the Rear (MSC) Side Exterior Doors**



- Step 2** Lift the doors and set them carefully aside. See the above image.  
**Caution** The doors scratch easily, so they should be handled with care.
- Step 3** (Removing the Upper Rear Air Grille) Follow these steps if you are using the vertical troughs. To remove the upper rear air grille if the vertical troughs are not used, see the [Removing the Upper Rear Air Grille and Rear Kick Plate if Vertical Troughs Are Not Used](#), on page 201.
- Step 4** Release the upper rear air grille from the ball stud retainers.
- Step 5** Carefully unhook the hanger brackets from the top of the vertical cable troughs as shown in the following image.

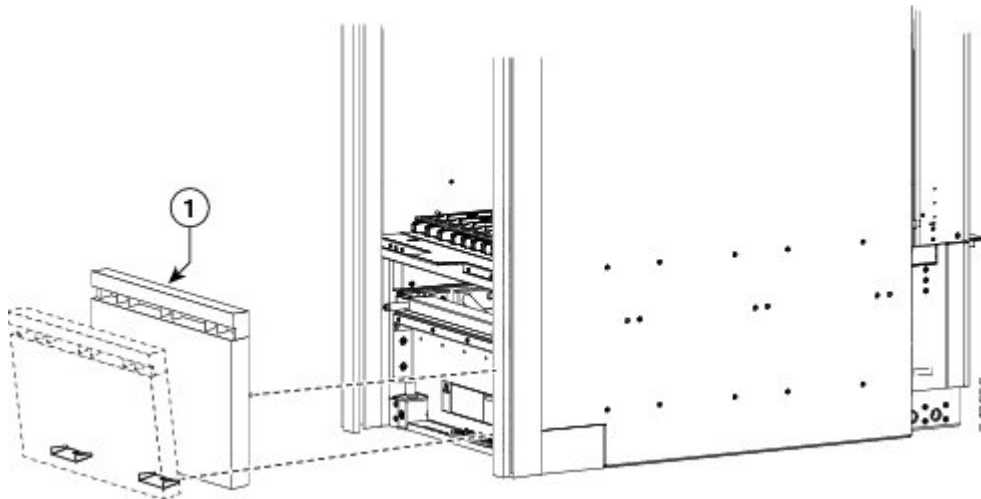


**Step 6** (Removing the Rear Kick Plate) Follow these steps if you are using the vertical troughs. To remove the rear kick plate if the vertical troughs are not used, see the [Removing the Upper Rear Air Grille and Rear Kick Plate if Vertical Troughs Are Not Used](#), on page 201.

**Step 7** Release the kick plate from the ball stud retainers.

**Step 8** Carefully remove the rear kick plate from the tabs on the bottom as shown in the following image.

**Figure 104: Removing the Rear Kick Plate**



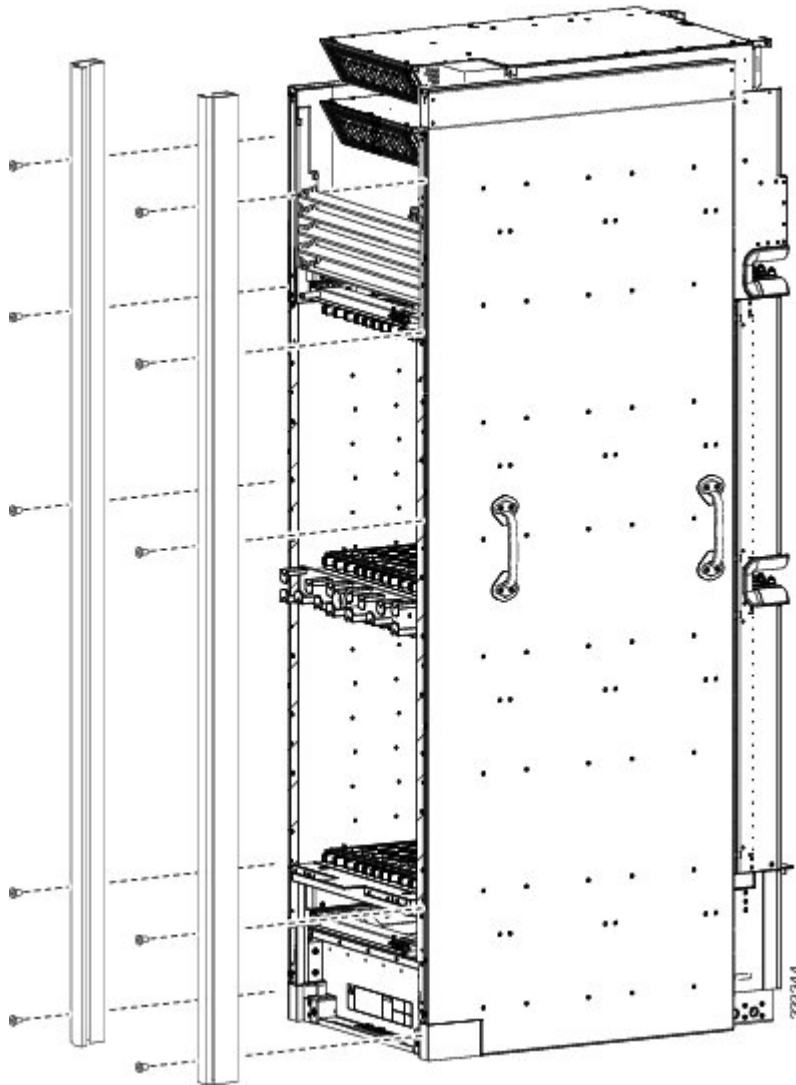
1	Rear kick plate
---	-----------------

**Step 9** (Removing the Rear Vertical Cable Troughs) Remove the rear vertical cable troughs—one left and one right—from the rear of the chassis as shown in the following image.

- a) Unscrew the ten M4x14-mm pan head screws (five on each side) that attach it to the chassis. (You might need to use a ladder to reach the upper screws.)
- b) Slide the cable troughs upward slightly to unhook them from the guide slots; lift them away from the chassis, and set them carefully aside.

**Note** We recommend that you use two people to remove the troughs, one person to hold the troughs in place while the other person removes the screws.

**Figure 105: Removing the Rear (MSC) Side Vertical Cable Troughs**



To remove the exhaust air deflector, see [Removing the Exhaust Air Deflector, on page 225](#) [Removing the Exhaust Air Deflector, on page 225](#).

# Removing the Upper Rear Air Grille and Rear Kick Plate if Vertical Troughs Are Not Used

If you are using the vertical troughs, see the [Removing the Rear \(MSC\) Side Cosmetic Components](#), on page 195.



**Note** Because the upper rear air grille is installed at the top of the chassis, it is easier to stand on a ladder while removing it.

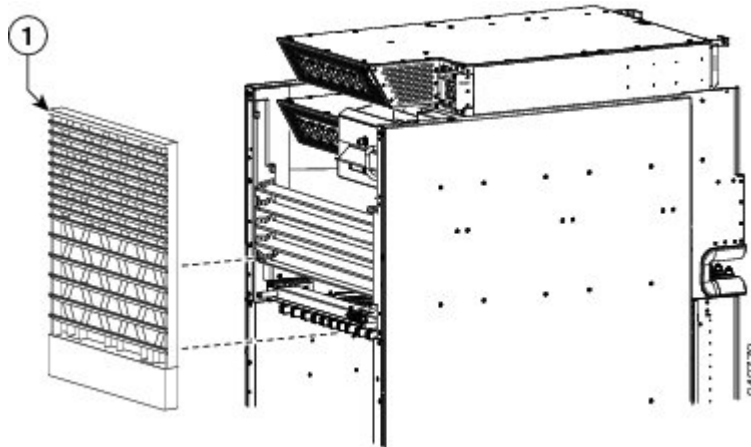
## SUMMARY STEPS

1. To remove the upper rear air grille, unhook it from the brackets and slide upward to release.
2. (Removing the Rear Kick Plate) To remove the rear kick plate, unsnap it from the tabs near the bottom of the chassis.
3. To remove the brackets installed with the kick plate, loosen the captive screws that attach the bracket to the chassis.

## DETAILED STEPS

**Step 1** To remove the upper rear air grille, unhook it from the brackets and slide upward to release.

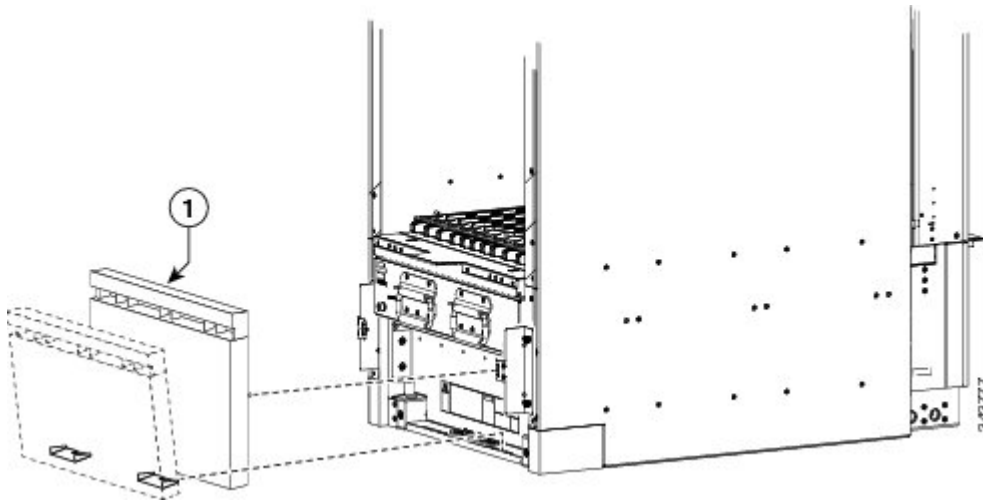
*Figure 106: Removing the Upper Rear Air Grille*



1	Upper rear air grille
---	-----------------------

**Step 2** (Removing the Rear Kick Plate) To remove the rear kick plate, unsnap it from the tabs near the bottom of the chassis.

**Figure 107: Removing the Rear Kick Plate**

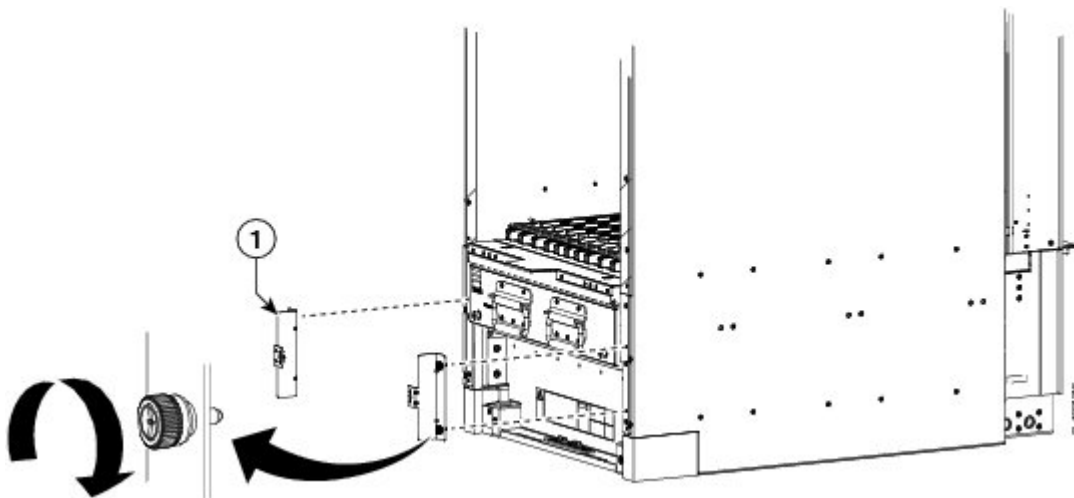


1

Rear kick plate

**Step 3** To remove the brackets installed with the kick plate, loosen the captive screws that attach the bracket to the chassis.

**Figure 108: Removing Brackets for the Lower Rear Kick Plate**



1

Brackets for rear kick plate



## What to Do Next

Be sure that all parts have been carefully set aside and repackaged appropriately.

## Removing the Front (PLIM) Side Cosmetic Components

This section describes how to remove exterior cosmetic components from the front (PLIM) side of the chassis. This section includes all the steps you need to remove all the cosmetic parts from the chassis. To remove a particular part, see the appropriate step or steps in the procedure that follows.

**Note**

While it is possible to remove most of the cosmetic parts on the Cisco CRS Series Enhanced 16-slot Line Card Chassis separately, some parts (such as a unistrut) require that other parts be removed first.

This section describes how to perform the following tasks:

## Prerequisites

Ensure that you have all the original packaging material for the cosmetic components available.

## Required Tools and Equipment

You need the following tools to perform this task:

- 8-in. long number 1 Phillips screwdriver—magnetic head preferable, bit size number 1
- 13-mm socket
- 2-mm hex key wrench (for door set screws)
- T8 Torx wrench (for removing upper grille support)

## Steps

To remove the front (PLIM) side external cosmetic components, perform the following steps:

## SUMMARY STEPS

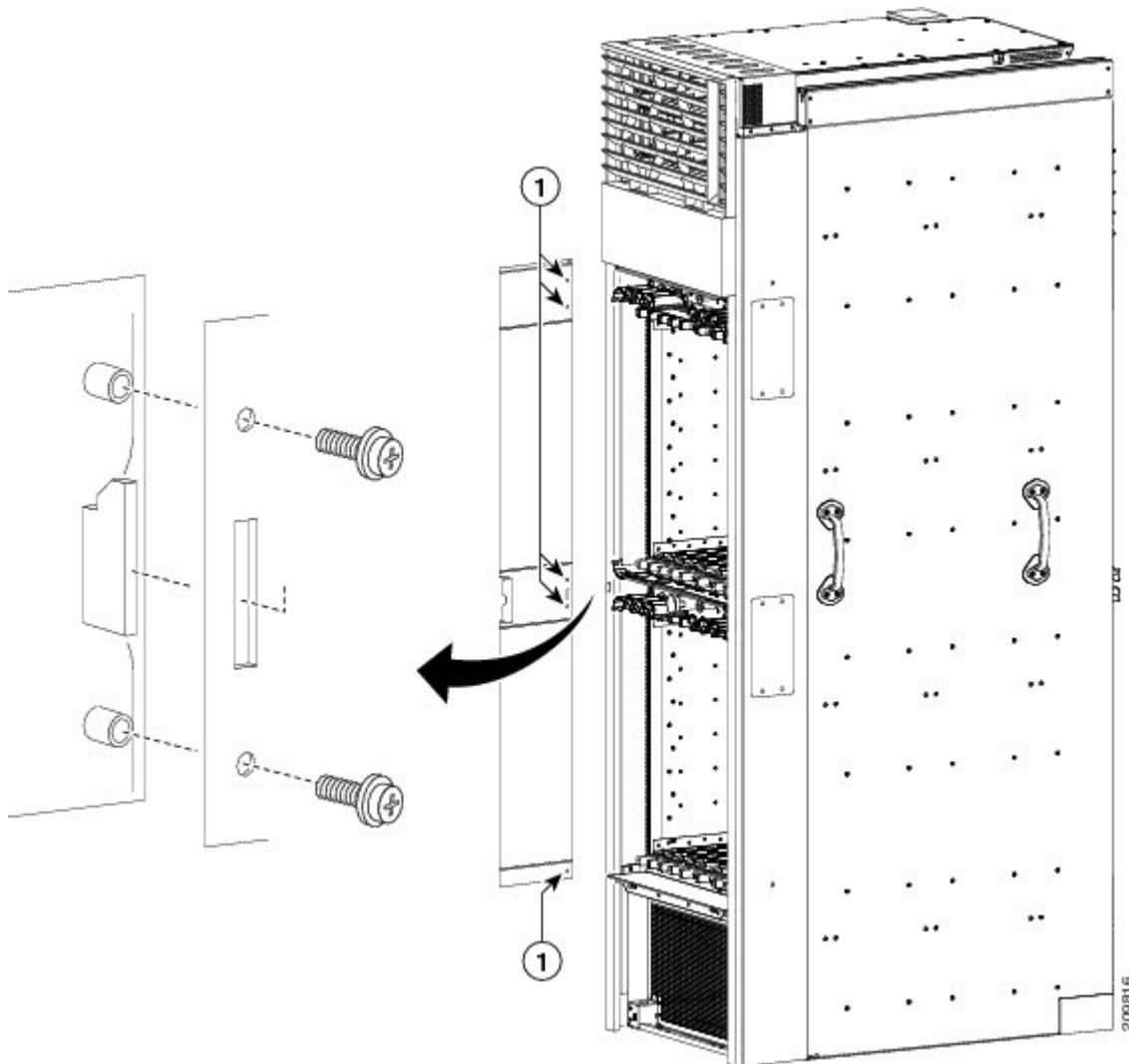
1. (Removing the Front Doors) Remove the screws from the doors. There are five M4 x 10 screws on each side for the metal sections of the doors and six M4 x 8 screws on each side for the plexiglass section of the door.
2. Lift the doors and set them carefully aside. See the following image.
3. (Removing the Front Lower Grille) Remove the front lower grille (see the following image) by unsnapping the top portion from the ball stud snaps on the grille frame.
4. Rotate the grille towards you on its brackets, and then lift it clear of the support, and set it carefully aside.
5. (Removing the Front Upper Grille) Remove the upper grille (see the following image) by unsnapping the bottom portion from the ball stud snaps on the chassis.
6. Rotate the grille towards you on its hook hanger brackets, then lift it clear of the support, and set it carefully aside.
7. (Removing the Default Front Vertical Cable Troughs) Remove the default vertical cable troughs (see the following image)—one right and one left—from the front (PLIM) side of the chassis:
8. (Removing the Optional Wide Front Vertical Cable Troughs) Remove the wide vertical cable troughs—one right and one left—from the front (PLIM) side of the chassis:
9. (Removing the Unistruts) Use the 13-mm socket and ratchet wrench to remove the four M12 hex head bolts and washers, two on each unistrut, that attach the unistrut to the top of the chassis.

## DETAILED STEPS

- 
- Step 1** (Removing the Front Doors) Remove the screws from the doors. There are five M4 x 10 screws on each side for the metal sections of the doors and six M4 x 8 screws on each side for the plexiglass section of the door.
- Note** To ensure that the door is well supported during removal, remove the screws in the upper and lower metal sections last.
- Step 2** Lift the doors and set them carefully aside. See the following image.

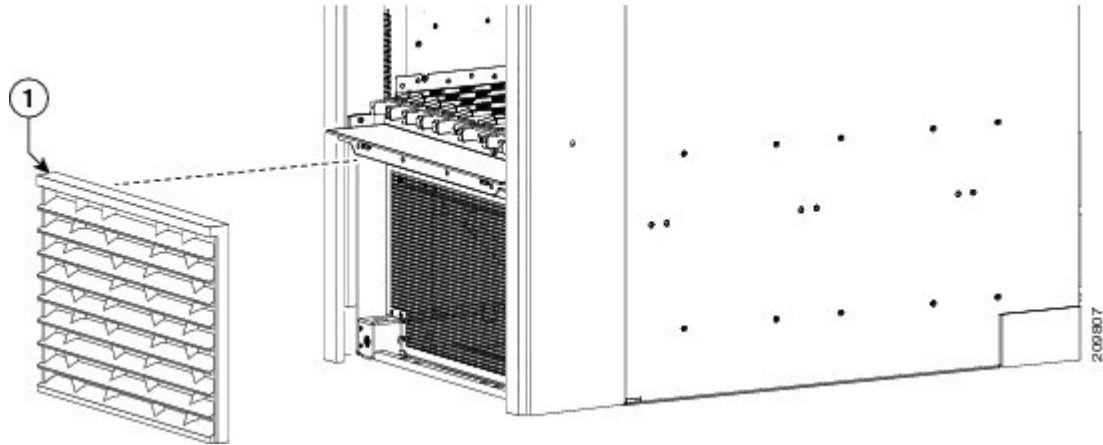
**Caution** The doors scratch easily, so they should be handled with care.

**Figure 109: Removing the Front Doors**



- Step 3** (Removing the Front Lower Grille) Remove the front lower grille (see the following image) by unsnapping the top portion from the ball stud snaps on the grille frame.
- Step 4** Rotate the grille towards you on its brackets, and then lift it clear of the support, and set it carefully aside.

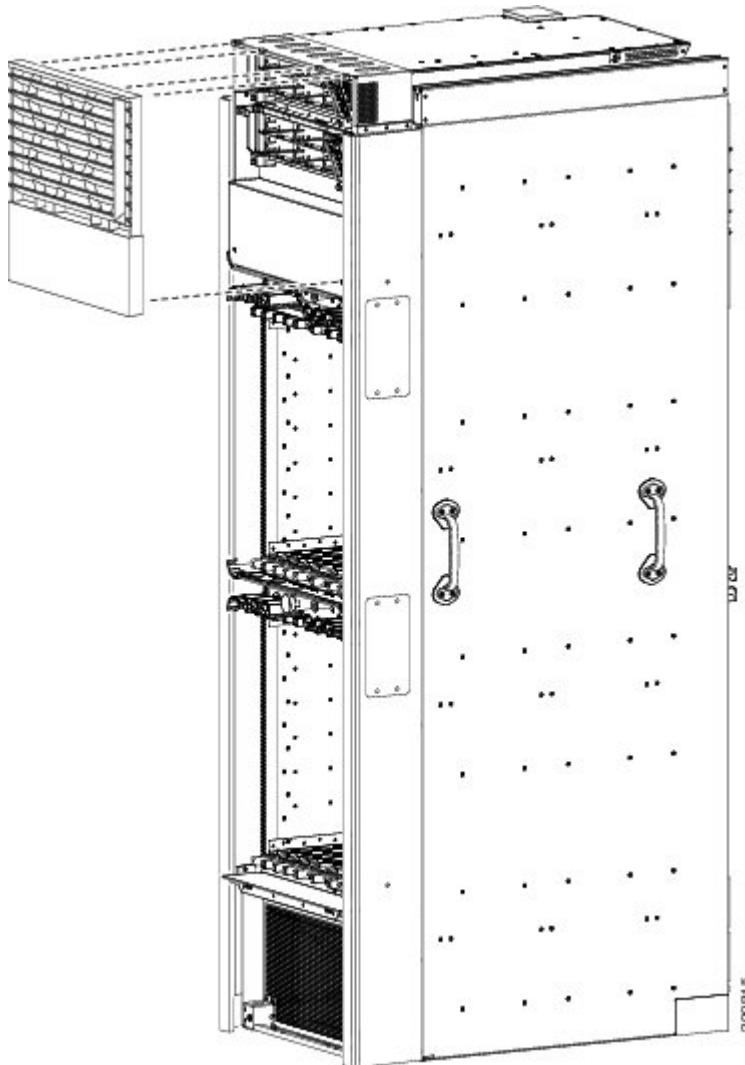
**Figure 110: Removing the Front Lower Grille**



**Step 5** (Removing the Front Upper Grille) Remove the upper grille (see the following image) by unsnapping the bottom portion from the ball stud snaps on the chassis.

**Step 6** Rotate the grille towards you on its hook hanger brackets, then lift it clear of the support, and set it carefully aside.

**Figure 111: Removing the Front Upper Grille**

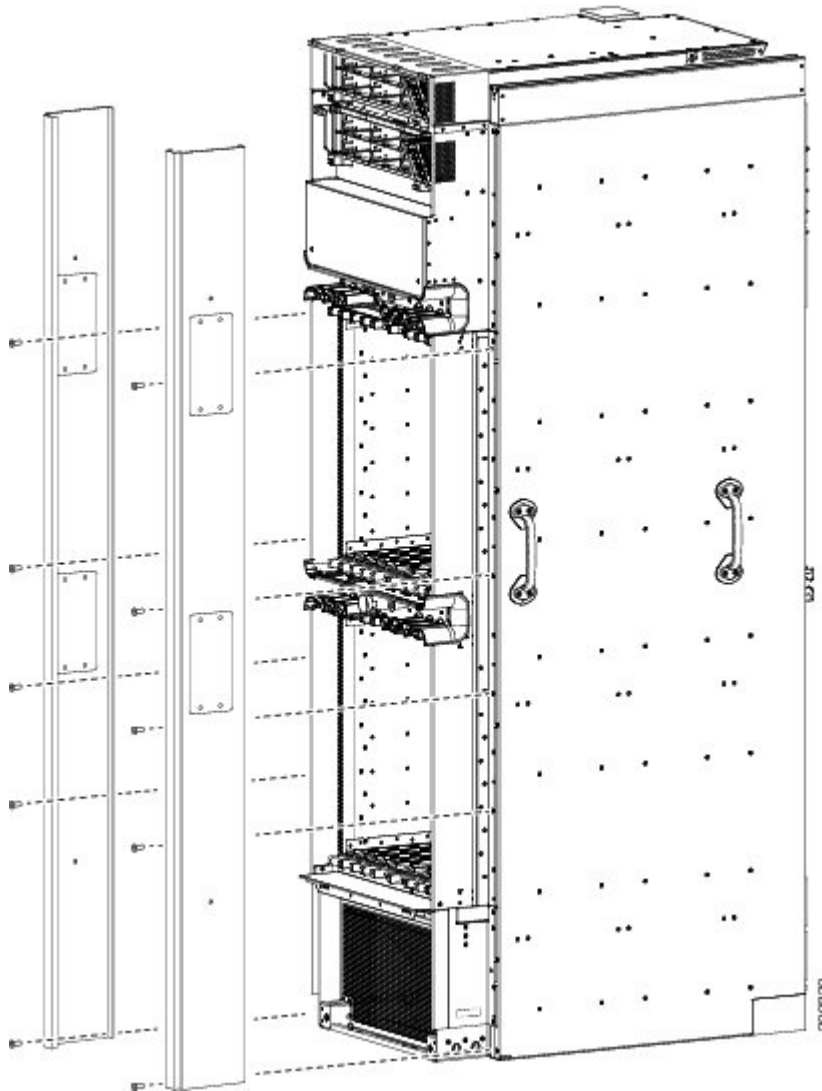


**Step 7** (Removing the Default Front Vertical Cable Troughs) Remove the default vertical cable troughs (see the following image)—one right and one left—from the front (PLIM) side of the chassis:

- a) Use the screwdriver to turn the twelve M4x14-mm flat head screws (six on each side) counterclockwise, remove them from the cable troughs, and set them aside.
- b) Slide the cable troughs upward slightly to unhook them from the guide slots; lift them away from the chassis, and set them aside.

**Note** We recommend that you use two people to remove the troughs, one person to hold the troughs while the other person removes the screws.

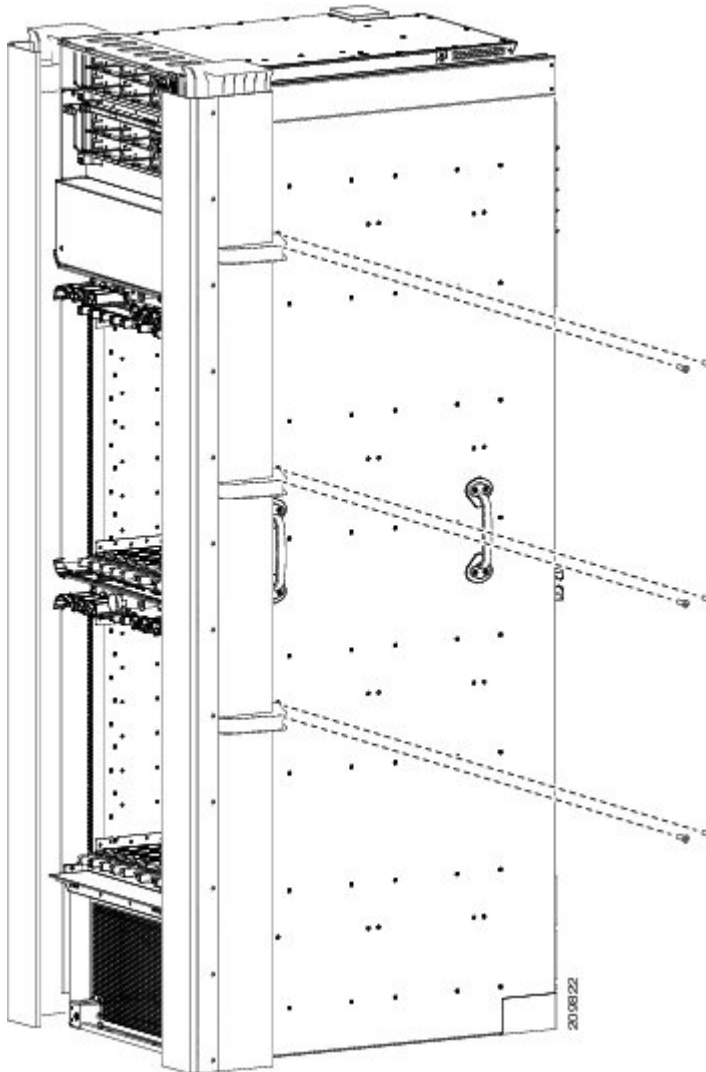
**Figure 112: Removing Default Vertical Cable Troughs from Chassis**



**Step 8** (Removing the Optional Wide Front Vertical Cable Troughs) Remove the wide vertical cable troughs—one right and one left—from the front (PLIM) side of the chassis:

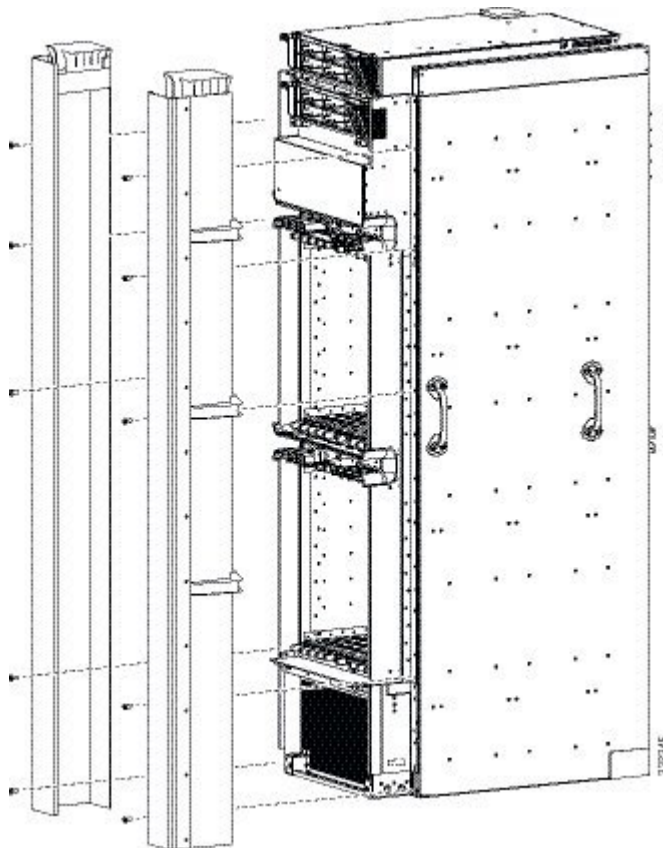
- a) Use the screwdriver to remove the six M8 screws that attach the three brackets (two screws on each bracket) on each trough to the side of the chassis. Set the screws aside.

**Figure 113: Removing Screws that Attach Wide Vertical Cable Trough Brackets to Side of Chassis**



- b) Use the screwdriver to turn the ten M4x14-mm flat head screws (five on each side) that attach the cable trough to the front of the chassis counterclockwise. Remove the screws from the cable troughs, and set them aside

**Figure 114: Removing Wide Vertical Troughs from Chassis**



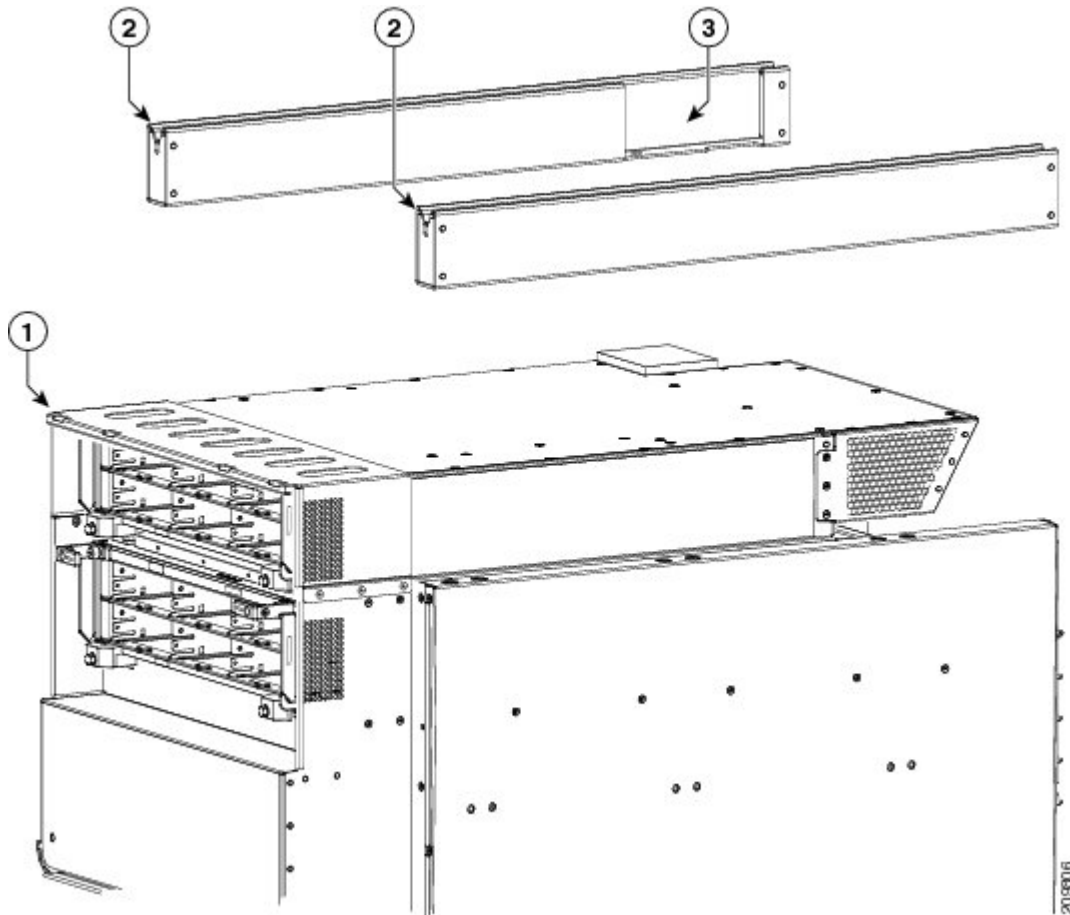
- c) Slide the cable troughs upward slightly to unhook them from the guide slots; lift them away from the chassis, and set them aside.

**Note** We recommend that you use two people to remove the troughs, one person to hold the troughs while the other person removes the screws.



**Step 9** (Removing the Unistruts) Use the 13-mm socket and ratchet wrench to remove the four M12 hex head bolts and washers, two on each unistrut, that attach the unistrut to the top of the chassis.

**Figure 115: Removing the Unistrut**



1	Upper grille support	3	Cutaway for ground cable
2	Unistruts		

## What to Do Next

Be sure that all parts have been carefully set aside and repackaged as appropriate.

# Replacing Air Circulation Components

This section provides instructions on how to install and replace the Cisco CRS Series Enhanced 16-Slot Line Card Chassis air circulation components.

**Note**

---

The chassis is shipped with the fan trays and air filter pre-installed.

---

This section presents the following topics:

## Information About the Air Circulation Components

This section contains some general information about the air circulation components in the following topics:

### About the Fan Trays

The Cisco CRS Series Enhanced 16-Slot Line Card Chassis has two fan trays , one just below the lower card cage and the other just above the upper card cage. The chassis can run with only one fan tray operating. If a failure occurs in one fan tray, the other fan tray acts as the redundant fan tray to assure fault-tolerant system performance; the chassis continues to operate while the failed fan tray is replaced.

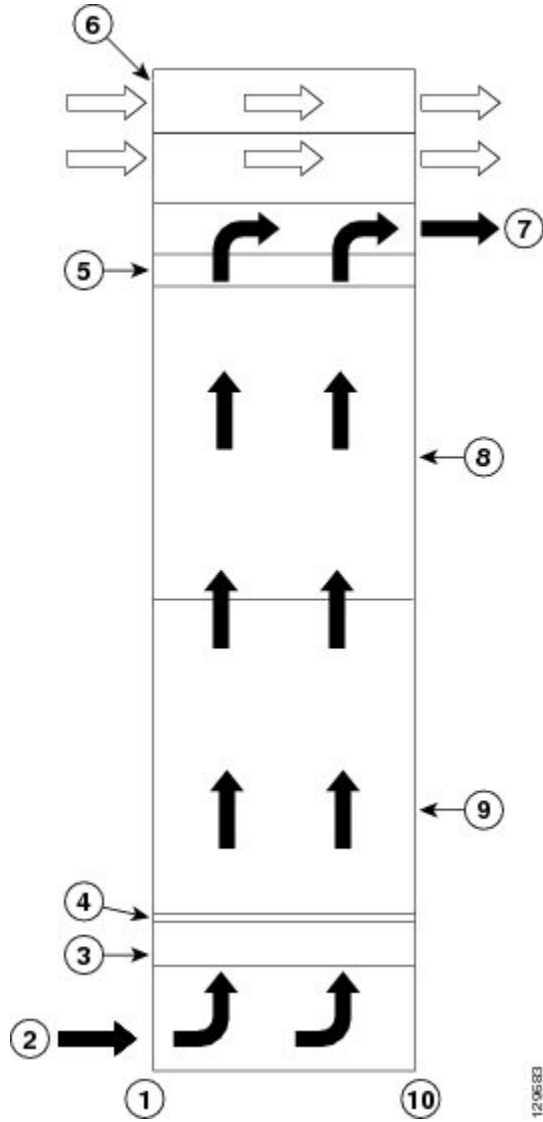
The Cisco CRS Series Enhanced 16-Slot Line Card Chassis fan tray operates in either the upper or lower fan tray slots. Each fan tray installs into the rear (MSC) side of the chassis and contains:

- Nine fans
- Fan tray board
- Front-panel status LED



**Note** The upper and lower fan trays are interchangeable and installed in the same manner.

**Figure 116: Airflow Through the Cisco CRS Series Enhanced 16-Slot Line Card Chassis**



1	Front (PLIM) side of chassis	6	Power shelves (two installed)
2	Air intake	7	Air exhaust
3	Lower fan tray	8	Upper card cage
4	Air filter	9	Lower card cage

5	Upper fan tray	10	Rear [MSC] side of chassis
---	----------------	----	----------------------------

## About the Air Filter

The chassis has a serviceable air filter mounted in a slide-out tray accessible from the rear of the chassis just below the lower card cage. The air filter removes dust from the room air drawn into the router by the two fan trays. Once a month (or more often in dusty environments) you should examine the air filter and replace it if it appears damaged or excessively dirty.

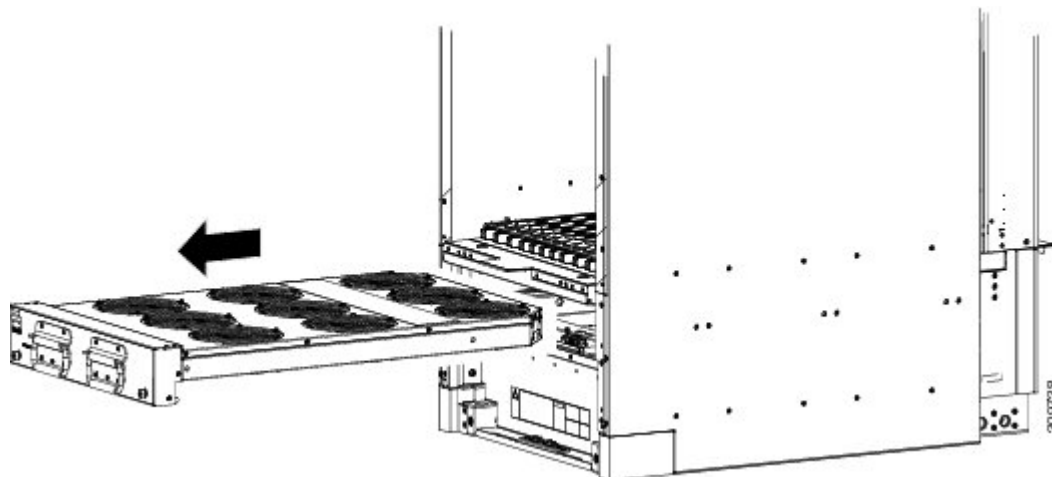
## How to Replace Air Circulation Components

This section contains the following procedures:

### Replacing a Fan Tray

This section describes how to replace a fan tray in the Cisco CRS Series Enhanced 16-Slot Line Card Chassis. For information on the fan tray, see the [Information About the Air Circulation Components](#), on page 212. For complete information on regulatory compliance and safety, see *Regulatory Compliance and Safety Information for the Cisco CRS Carrier Routing System*.

**Figure 117: Fan Tray**



## Prerequisites

Before performing this task, you must first open the chassis doors on the rear (MSC) side of the chassis, if installed. If you are replacing the upper fan tray, you must remove the upper grille from the rear (MSC) side of the chassis. If you are replacing the lower fan tray, you must remove the rear kick plate from the rear (MSC) side of the chassis.

## Required Tools and Equipment

You need the following tools and part to perform this task:

- ESD-preventive wrist strap
- 6-in. long number 1 Phillips screwdriver
- Fan tray—Cisco product number CRS-16-FANTRAY=

### Steps

To replace a fan tray, perform the following steps:

#### SUMMARY STEPS

1. Attach the ESD-preventive wrist strap to your wrist and connect its leash to one of the ESD connection sockets: on the front (PLIM) side of the chassis there is one ESD connection socket right above the fan controllers. On the rear (MSC) side of the chassis there are two ESD connection sockets right above the cable management tray in the center of the chassis (left and right). You can also connect the ESD-preventive wrist strap leash to any bare metal surface on the chassis.
2. Using the screwdriver, loosen the two captive screws on the fan tray faceplate. If necessary, use a step platform to reach the upper fan tray comfortably.
3. Pull firmly on the two handles to pull it free; two people are required to remove the fan tray.
4. Grasp the fan tray handles and pull it straight out to disconnect the fan tray from the connector mounted on the front of the fan tray bay on the rear (MSC) side of the chassis. Slide the fan tray halfway from the fan tray bay.
5. Use your free hands to support the fan tray, then slide the fan tray completely from the fan tray bay.
6. Set the fan tray carefully aside.
7. To install the replacement fan tray using two hands to support it, position the fan tray in front of the fan tray bay (label is on top).
8. Slide the fan tray into the fan tray bay. Stop when the fan tray makes contact with the chassis connector in the back of the fan tray bay.
9. Firmly push on the fan tray handles to seat the fan tray connector in the chassis connector. When completely seated, the fan tray faceplate flanges meet the rear (MSC) side of the chassis.
10. Tighten the two captive screws on the fan tray faceplate.

#### DETAILED STEPS

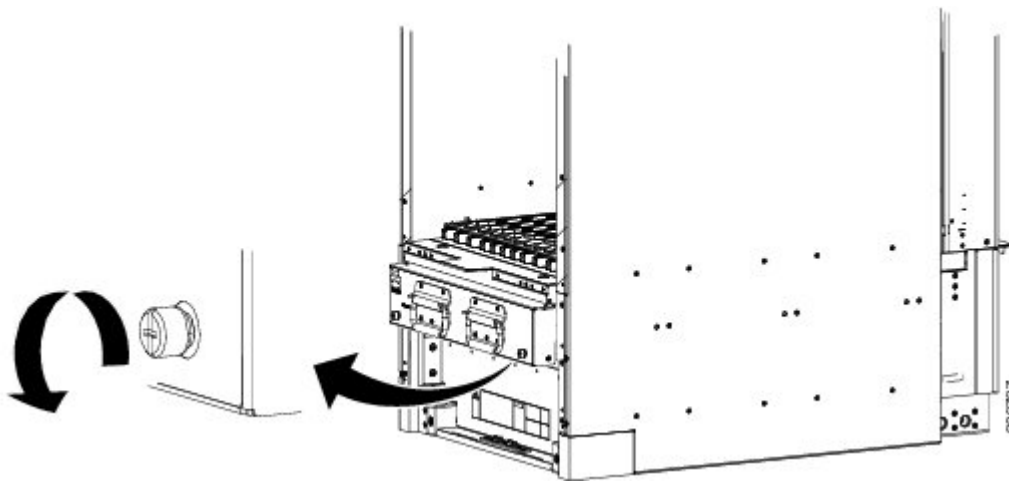
##### Step 1

Attach the ESD-preventive wrist strap to your wrist and connect its leash to one of the ESD connection sockets: on the front (PLIM) side of the chassis there is one ESD connection socket right above the fan controllers. On the rear (MSC) side of the chassis there are two ESD connection sockets right above the cable management tray in the center of the

chassis (left and right). You can also connect the ESD-preventive wrist strap leash to any bare metal surface on the chassis.

- Step 2** Using the screwdriver, loosen the two captive screws on the fan tray faceplate. If necessary, use a step platform to reach the upper fan tray comfortably.

**Figure 118: Unscrewing the Screws in the Fan Tray Faceplate**



- Step 3** Pull firmly on the two handles to pull it free; two people are required to remove the fan tray.
- Caution** Because of the weight of the fan tray, approximately 37.5 lb. (17 kg), two people are required to remove the fan tray. You should be especially careful while removing the fan tray from the chassis. To prevent injury, keep your back straight and lift with your legs, not your back. Avoid sudden twists or lateral moves. It is safer to use two people to remove the fan tray rather than a single person.
- Step 4** Grasp the fan tray handles and pull it straight out to disconnect the fan tray from the connector mounted on the front of the fan tray bay on the rear (MSC) side of the chassis. Slide the fan tray halfway from the fan tray bay.
- Step 5** Use your free hands to support the fan tray, then slide the fan tray completely from the fan tray bay.
- Step 6** Set the fan tray carefully aside.
- Step 7** To install the replacement fan tray using two hands to support it, position the fan tray in front of the fan tray bay (label is on top).
- Caution** Because of the weight of the fan tray, approximately 37.5 lb. (17 kg), two people are required to replace the fan tray. You should be especially careful while replacing the fan tray into the chassis. To prevent injury, keep your back straight and lift with your legs, not your back. Avoid sudden twists or lateral moves. It is safer to use two people to support the fan tray while replacing it in the fan tray bay rather than a single person.
- Step 8** Slide the fan tray into the fan tray bay. Stop when the fan tray makes contact with the chassis connector in the back of the fan tray bay.
- Caution** To prevent damage to the chassis connector, do not use excessive force when inserting a fan tray into its bay.
- Step 9** Firmly push on the fan tray handles to seat the fan tray connector in the chassis connector. When completely seated, the fan tray faceplate flanges meet the rear (MSC) side of the chassis.
- Note** All electrical and control line connections are made automatically when the connectors mate. The Fan LED will light when the fan tray is inserted.
- Step 10** Tighten the two captive screws on the fan tray faceplate.

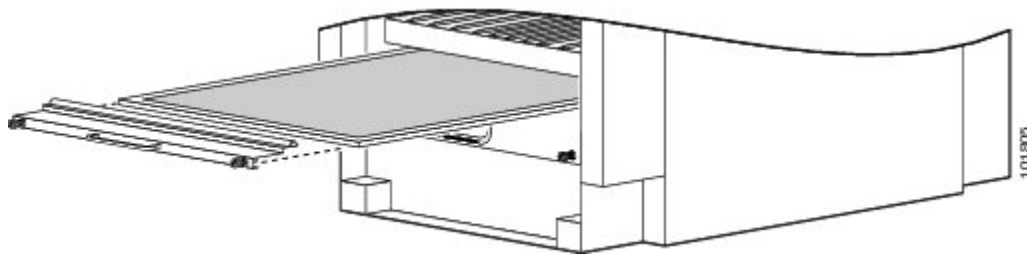
## What to Do Next

After performing this task, close the doors (if installed) and re-install the upper grille or rear kick plate on the rear (MSC) side of the chassis, as necessary. For more information, see the [Installing the Rear \(MSC\) Side Cosmetic Components](#), on page 97.

## Replacing the Air Filter

This section describes how to replace the air filter in the Cisco CRS Series Enhanced 16-Slot Line Card Chassis. For further information, see the [Information About the Air Circulation Components](#), on page 212. For complete information on regulatory compliance and safety, see *Regulatory Compliance and Safety Information for the Cisco CRS Carrier Routing System*.

**Figure 119: Air Filter**



### Note

A lattice of wire exists on both sides of the filter material with an arrow denoting airflow direction and a pair of sheet metal straps on the downstream side of the filter assembly.

## Prerequisites

Before performing this task, you must first open the doors and remove the lower grille on the Rear (MSC) side of the chassis. See the [Removing the Rear \(MSC\) Side Cosmetic Components](#), on page 195 for more information.



### Caution

Never operate the Cisco CRS Series Enhanced 16-Slot Line Card Chassis without an air filter. Operating a Cisco CRS Series Enhanced 16-Slot Line Card Chassis without a filter or leaving an air filter cover off for an extended time can result in damage to the hardware.

## Required Tools and Equipment

You need the following tools and part to perform this task:

- ESD-preventive wrist strap

- 6-in. long number 1 Phillips screwdriver
- Air filter—Cisco product number CRS-16-FILTER=

## Steps

To replace the air filter, perform the following steps:

### SUMMARY STEPS

1. Attach the ESD-preventive wrist strap to your wrist and connect its leash to one of the ESD connection sockets on the front (PLIM) side of the chassis or a bare metal surface on the chassis.
2. Using the screwdriver, loosen the two captive screws on the filter cover faceplate. Pull firmly on the cover to swing it free; some force may be required.
3. Insert the new air filter on top of the existing (old) air filter and push the new air filter into the air filter slot until it is seated fully within the slot.
4. Grasp the tabs at the front of the existing (old) air filter beneath the new air filter and carefully slide it from the slot.
5. Set this old air filter carefully aside.
6. Replace the filter cover and tighten the two captive screws on the front.

### DETAILED STEPS

- 
- |               |  |
|---------------|--|
| <b>Step 1</b> | Attach the ESD-preventive wrist strap to your wrist and connect its leash to one of the ESD connection sockets on the front (PLIM) side of the chassis or a bare metal surface on the chassis. |
| <b>Step 2</b> | Using the screwdriver, loosen the two captive screws on the filter cover faceplate. Pull firmly on the cover to swing it free; some force may be required.                                     |
| <b>Step 3</b> | Insert the new air filter on top of the existing (old) air filter and push the new air filter into the air filter slot until it is seated fully within the slot.                               |
| <b>Step 4</b> | Grasp the tabs at the front of the existing (old) air filter beneath the new air filter and carefully slide it from the slot.  |
| <b>Step 5</b> | Set this old air filter carefully aside.   |
| <b>Step 6</b> | Replace the filter cover and tighten the two captive screws on the front.  |
- 

## What to Do Next

After performing this task, re-install the lower grille and close the doors on the Rear (MSC) side of the chassis. For more information, see the [Removing the Rear \(MSC\) Side Cosmetic Components](#), on page 195.

# Removing Power Components

This section describes how to remove power components from the Cisco CRS enhanced 16-slot line card chassis.



**Note**

Although there are differences between the different types of power shelves and PMs (AC and DC), they are installed and removed using the same procedures.

While it is possible to remove power components from the Cisco CRS enhanced 16-slot line card chassis separately, some parts (such as the power shelf) require that other parts be removed first.

We recommend that you remove the power components in the order outlined in this section. This section contains the following procedures:

## Removing a Power Module Slot Cover

This section describes how to remove a PM slot cover from a PM slot in an AC or DC power shelf. For complete information on regulatory compliance and safety, see *Regulatory Compliance and Safety Information for the Cisco CRS Carrier Routing System*.

### Prerequisites

Before performing this task, you must first remove the upper grille on the front (SFC) side of the chassis, if installed. See the [Removing the Upper Grille Support](#), on page 233.

### Required Tools and Equipment

You need the following tools to perform this task:

- ESD-preventive wrist strap

### Steps

To remove a PM slot cover from a power shelf, perform the following steps:

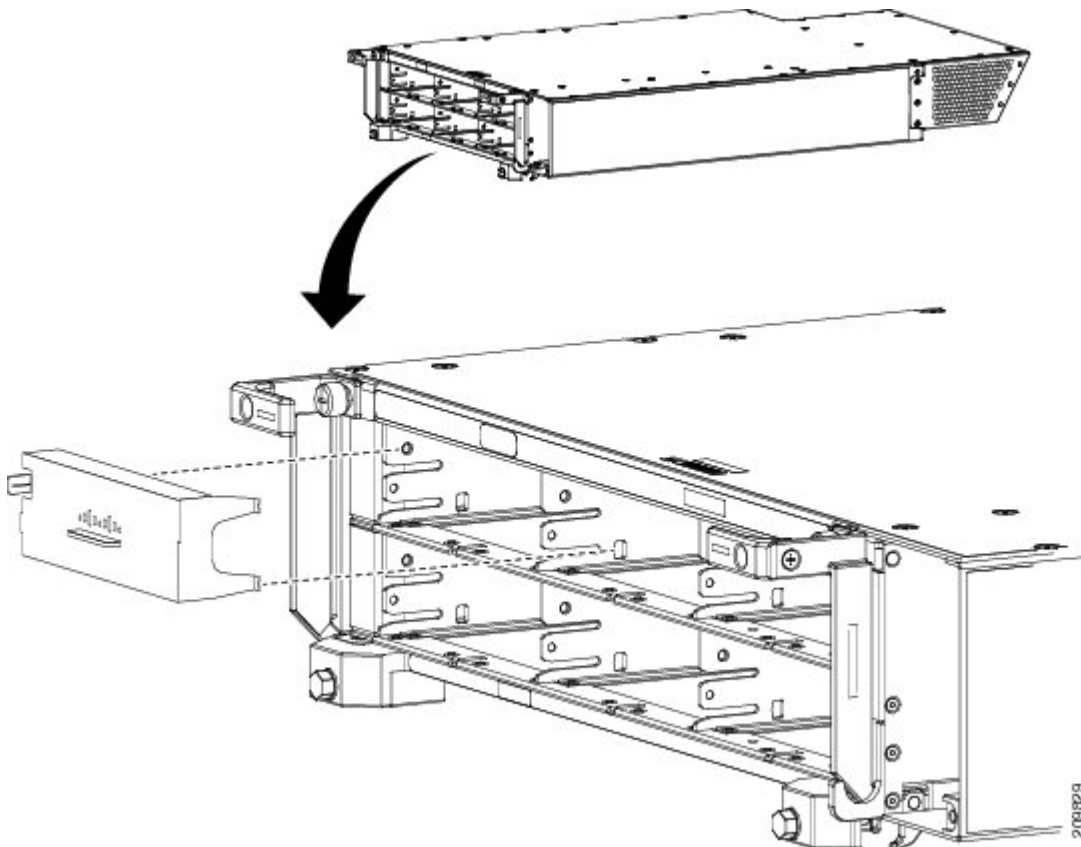
#### SUMMARY STEPS

1. Attach the ESD-preventive wrist strap to your wrist and connect its leash to one of the ESD connection sockets: on the front (PLIM) side of the chassis there is one ESD connection socket right above the fan controllers. On the rear (MSC) side of the chassis there are two ESD connection sockets right above the cable management tray in the center of the chassis (left and right). You can also connect the ESD-preventive wrist strap leash to any bare metal surface on the chassis.
2. Gently pinch the tab on the left side of the PM slot cover to detach the PM slot cover from the PM slot.
3. Remove the two tabs on the right side of the PM slot cover from the two holes on the right side of the PM slot.
4. Set the PM slot cover aside.

## DETAILED STEPS

- Step 1** Attach the ESD-preventive wrist strap to your wrist and connect its leash to one of the ESD connection sockets: on the front (PLIM) side of the chassis there is one ESD connection socket right above the fan controllers. On the rear (MSC) side of the chassis there are two ESD connection sockets right above the cable management tray in the center of the chassis (left and right). You can also connect the ESD-preventive wrist strap leash to any bare metal surface on the chassis.
- Step 2** Gently pinch the tab on the left side of the PM slot cover to detach the PM slot cover from the PM slot.
- Step 3** Remove the two tabs on the right side of the PM slot cover from the two holes on the right side of the PM slot.
- Step 4** Set the PM slot cover aside.

*Figure 120: Installing PM Slot Cover*



## What to Do Next

After performing this task, install an AC or DC PM, if necessary. For more information, see [Installing a Power Module](#), on page 63. Re-install the upper grille on the front (SFC) side of the chassis. If you plan to remove the power shelf completely, you must first remove all of the PM slot covers, PMs, and the alarm module from

the power shelf. See the [Removing a Power Module, on page 221](#) and the [Removing an Alarm Module, on page 222](#) for more information.

## Removing a Power Module

This section describes how to remove a PM from a power shelf. For complete information on regulatory compliance and safety, see *Regulatory Compliance and Safety Information for the Cisco CRS Carrier Routing System*.

### Prerequisites

Before performing this task, you must first remove the upper grille on the front (PLIM) side of the chassis, if installed.

### Required Tools and Equipment

You need the following tools to perform this task:

- ESD-preventive wrist strap
- 6-in. long number 1 Phillips screwdriver

### Steps

To remove a PM from a power shelf, perform the following steps:

#### SUMMARY STEPS

1. Attach the ESD-preventive wrist strap to your wrist and connect its leash to one of the ESD connection sockets: on the front (PLIM) side of the chassis there is one ESD connection socket right above the fan controllers. On the rear (MSC) side of the chassis there are two ESD connection sockets right above the cable management tray in the center of the chassis (left and right). You can also connect the ESD-preventive wrist strap leash to any bare metal surface on the chassis.
2. Using the screwdriver, unscrew the ejector from the PM.
3. Flip down the ejector. Slide the PM out of the power shelf, and carefully place it down on a flat surface.

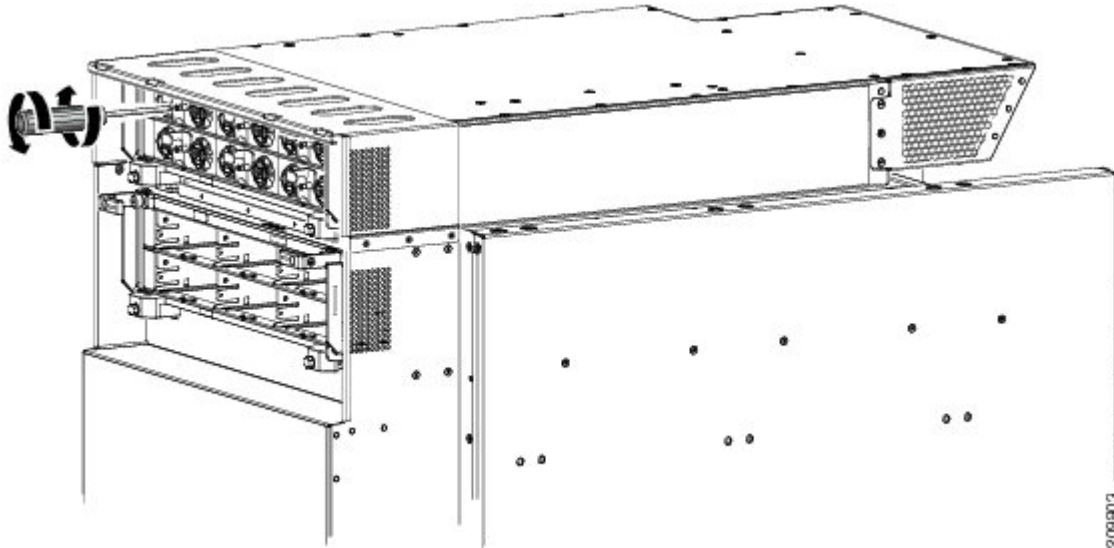
#### DETAILED STEPS

- 
- Step 1** Attach the ESD-preventive wrist strap to your wrist and connect its leash to one of the ESD connection sockets: on the front (PLIM) side of the chassis there is one ESD connection socket right above the fan controllers. On the rear (MSC) side of the chassis there are two ESD connection sockets right above the cable management tray in the center of the

chassis (left and right). You can also connect the ESD-preventive wrist strap leash to any bare metal surface on the chassis.

**Step 2** Using the screwdriver, unscrew the ejector from the PM.

**Figure 121: Removing the PM from the Power Shelf**



**Step 3** Flip down the ejector. Slide the PM out of the power shelf, and carefully place it down on a flat surface.

## What to Do Next

After performing this task, install a replacement AC or DC PM, if necessary (see [Installing a Power Module, on page 63](#)) and re-install the upper grille on the front (SFC) side of the chassis. If you plan to remove the power shelf completely, you must first remove all of the power modules and the alarm module from the power shelf (see [Removing an Alarm Module, on page 222](#)).

## Removing an Alarm Module

This section describes how to remove an alarm module from a power shelf installed in the Cisco CRS enhanced 16-slot line card chassis. For complete information on regulatory compliance and safety, see *Regulatory Compliance and Safety Information for the Cisco CRS Carrier Routing System*.

## Prerequisites

Before performing this task, you must first remove the upper grille on the front (SFC) side of the chassis, if installed. See [Removing the Front \(PLIM\) Side Cosmetic Components, on page 203](#).

## Required Tools and Equipment

You need the following tools to perform this task:

- ESD-preventive wrist strap
- 6-in. long number 1 Phillips screwdriver

## Steps

To remove the alarm module, perform the following steps:

### SUMMARY STEPS

1. Attach the ESD-preventive wrist strap to your wrist and connect its leash to one of the ESD connection sockets: on the front (PLIM) side of the chassis there is one ESD connection socket right above the fan controllers. On the rear (MSC) side of the chassis there are two ESD connection sockets right above the cable management tray in the center of the chassis (left and right). You can also connect the ESD-preventive wrist strap leash to any bare metal surface on the chassis.
2. Use the screwdriver to loosen the captive screw securing the alarm module to the power shelf on the lower right corner of the alarm module.
3. Rotate the alarm module ejector lever downwards to eject the alarm module from the power shelf.
4. Slide the alarm module out of the power shelf, and carefully place it down on a flat surface.

### DETAILED STEPS

#### Step 1

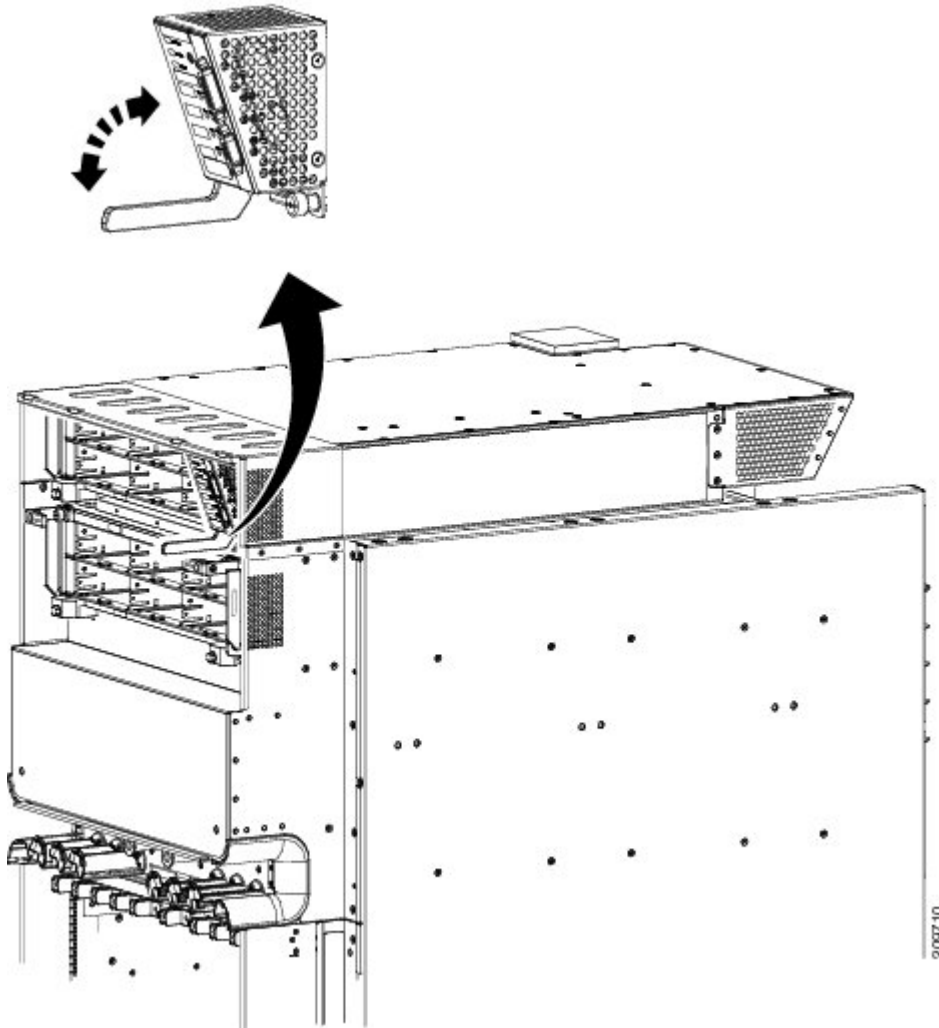
---

Attach the ESD-preventive wrist strap to your wrist and connect its leash to one of the ESD connection sockets: on the front (PLIM) side of the chassis there is one ESD connection socket right above the fan controllers. On the rear (MSC) side of the chassis there are two ESD connection sockets right above the cable management tray in the center of the

chassis (left and right). You can also connect the ESD-preventive wrist strap leash to any bare metal surface on the chassis.

- Step 2** Use the screwdriver to loosen the captive screw securing the alarm module to the power shelf on the lower right corner of the alarm module.
- Step 3** Rotate the alarm module ejector lever downwards to eject the alarm module from the power shelf.

**Figure 122: Rotating Alarm Module Ejector Downwards to Eject Alarm Module**



- Step 4** Slide the alarm module out of the power shelf, and carefully place it down on a flat surface.
-

## What to Do Next

After performing this task, install a replacement alarm module, if necessary, (see [Installing an Alarm Module, on page 58](#)) and re-install the upper grille on the front (SFC) side of the chassis. If you plan to remove the power shelf completely, remove the AC or DC wiring from the rear of the power shelf (see [Removing AC or DC Power Shelf Wiring, on page 227](#)). If you plan to remove wiring from the lower power shelf, you will need to remove the exhaust air deflector first (see [Removing the Exhaust Air Deflector, on page 225](#)).

## Removing the Exhaust Air Deflector

This section describes how to remove the exhaust air deflector from the rear of the Cisco CRS enhanced 16-slot line card chassis. For complete information on regulatory compliance and safety, see *Regulatory Compliance and Safety Information for the Cisco CRS Carrier Routing System*.

The exhaust air deflector must be removed before installing the lower power shelf.

### Prerequisites

There are no prerequisites for this task.

### Required Tools and Equipment

You need the following tools and equipment to perform this task:

- 6-in. long number 2 Phillips screwdriver

### Steps

#### SUMMARY STEPS

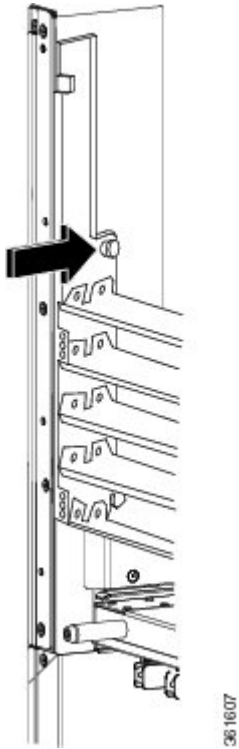
1. Unscrew the captive screw on both sides.
2. Rotate the air deflector backward until seated on the lower standoff.
3. Lift the air deflector off of the lower standoff.

## DETAILED STEPS

---

- Step 1** Unscrew the captive screw on both sides.

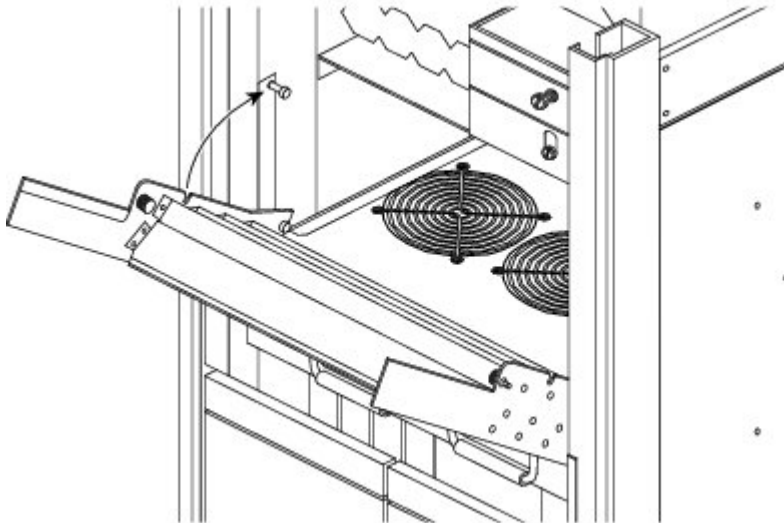
*Figure 123: The Captive Screw*





**Step 2** Rotate the air deflector backward until seated on the lower standoff.

**Figure 124: Rotating the Air Deflector Backward**



**Step 3** Lift the air deflector off of the lower standoff.

---

## What to Do Next

After the exhaust air deflector has been removed from the rear of the chassis, remove the AC or DC wiring from the rear of the power shelf. Continue to [Installing an AC or DC Power Shelf](#), on page 42 for instructions.

## Removing AC or DC Power Shelf Wiring

This section describes how to remove the DC input wiring, DC terminal block covers and AC cords from the rear of the power shelf on the Cisco CRS enhanced 16-slot line card chassis. For complete information on regulatory compliance and safety, see *Regulatory Compliance and Safety Information for the Cisco CRS Carrier Routing System*.

### Removing DC Power Shelf Wiring

This section describes how to remove the DC power shelf wiring from the rear of the DC power shelf.

For additional power shelf details, see Cisco CSR-1 Series Carrier Routing System Description or [Cisco CRS 16-Slot EC Line Card Chassis Specifications](#), on page 263.

## Prerequisites

Before performing this task, power down and remove DC PMs and the alarm module in the shelf you want to disconnect. Remove the upper grille from the rear (MSC) side of the chassis, if installed. If you plan to remove power from the lower power shelf, remove the exhaust air deflector from the rear of the chassis first. See [Removing the Exhaust Air Deflector](#), on page 225.

**Note**

---

Before removing wiring from the power shelf, make sure that the input power cables are not energized.

---

## Required Tools and Equipment

You need the following tools to perform this task:

- ESD-preventive wrist strap
- 6-in. long number 1 Phillips screwdriver
- 3/8-in. ratchet wrench with 10-mm socket
- Volt ohm meter

## Steps

To disconnect wiring from the DC power shelf, perform the following steps:

### SUMMARY STEPS

1. Attach the ESD-preventive wrist strap to your wrist and connect its leash to one of the ESD connection sockets: on the front (PLIM) side of the chassis there is one ESD connection socket right above the fan controllers. On the rear (MSC) side of the chassis there are two ESD connection sockets right above the cable management tray in the center of the chassis (left and right). You can also connect the ESD-preventive wrist strap leash to any bare metal surface on the chassis.
2. Verify that the power LEDs on the rear of the power shelf are off for all inputs on the power shelf that is being removed.
3. Using the volt ohm meter, verify that there is no voltage on the cables that are about to be removed.
4. Use the screwdriver to remove the screw that secures the terminal block cover into the mounting standoff.
5. Slide the terminal block cover downwards.
6. Remove the terminal block cover.
7. Using the 10-mm socket wrench, remove the positive and negative cable pairs from each terminal block.
8. Replace the terminal block cover.

### DETAILED STEPS

- 
- Step 1** Attach the ESD-preventive wrist strap to your wrist and connect its leash to one of the ESD connection sockets: on the front (PLIM) side of the chassis there is one ESD connection socket right above the fan controllers. On the rear (MSC) side of the chassis there are two ESD connection sockets right above the cable management tray in the center of the

chassis (left and right). You can also connect the ESD-preventive wrist strap leash to any bare metal surface on the chassis.

- Step 2** Verify that the power LEDs on the rear of the power shelf are off for all inputs on the power shelf that is being removed.
- Step 3** Using the volt ohm meter, verify that there is no voltage on the cables that are about to be removed.
- Step 4** Use the screwdriver to remove the screw that secures the terminal block cover into the mounting standoff.
- Step 5** Slide the terminal block cover downwards.
- Step 6** Remove the terminal block cover.
- Step 7** Using the 10-mm socket wrench, remove the positive and negative cable pairs from each terminal block.
- Note** When a cable is removed from the rear of the DC power shelf, we recommend that it should be wrapped with standard black electrical tape.
- Step 8** Replace the terminal block cover.
- 

## What To Do Next

After you remove the DC terminal block covers and DC wiring, you can remove the power shelf from the chassis completely. See [Removing a Power Shelf](#), on page 231.

## Removing AC Power Shelf Wiring

This section describes how to remove input AC cords from the rear of the DC power shelf.

### Prerequisites

Before performing this task, power down and remove AC PMs and the alarm module in the shelf you want to disconnect. Remove the upper grille from the rear (MSC) side of the chassis, if installed.



---

**Note** Before removing wiring from the power shelf, make sure that the input power cables are not energized.

---

### Required Tools and Equipment

You need the following tools to perform this task:

- 6-in. long number 1 Phillips screwdriver

### Steps

To remove the input AC cords, go to the rear of the chassis and perform the following steps:

## SUMMARY STEPS

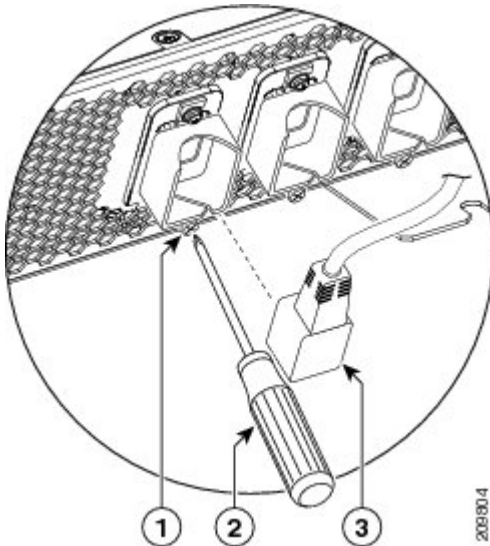
1. Verify that the AC input source breaker is in the OFF position.
2. Use the screwdriver to loosen the screws that clamp the cords in place.
3. Remove the cords from the cord clamps.

## DETAILED STEPS

**Step 1** Verify that the AC input source breaker is in the OFF position.

**Step 2** Use the screwdriver to loosen the screws that clamp the cords in place.

*Figure 125: Cord Being Removed from Cord Clamp*



1	Screw that secures the cord clamp
2	Cord to be inserted into clamp

**Step 3** Remove the cords from the cord clamps.

## What To Do Next

After you remove the AC cords, you can remove the power shelf from the chassis completely. See [Removing a Power Shelf](#), on page 231.

## Removing a Power Shelf

This section describes how to remove the power shelf from the Cisco CRS enhanced 16-slot line card chassis. For complete information on regulatory compliance and safety, see *Regulatory Compliance and Safety Information for the Cisco CRS Carrier Routing System*.

### Prerequisites

Before performing this task, remove the upper grilles from the front (PLIM) and rear (MSC) sides of the chassis (if installed), the AC or DC PMs, alarm module, and the AC or DC input power wiring from the shelf that you want to disconnect. For more information, see the [Removing a Power Module, on page 221](#), the [Removing an Alarm Module, on page 222](#), and the [Removing AC or DC Power Shelf Wiring, on page 227](#).

### Required Tools and Equipment

You need the following tools to perform this task:

- 6 in. long number 2 Phillips screwdriver



#### Caution

Do not use the handles for lifting or supporting the power shelf, because this could severely damage the handles.



#### Caution

Do not bend the handles sideways during any part of the removal process.

### Steps

To remove a power shelf, perform the following steps:

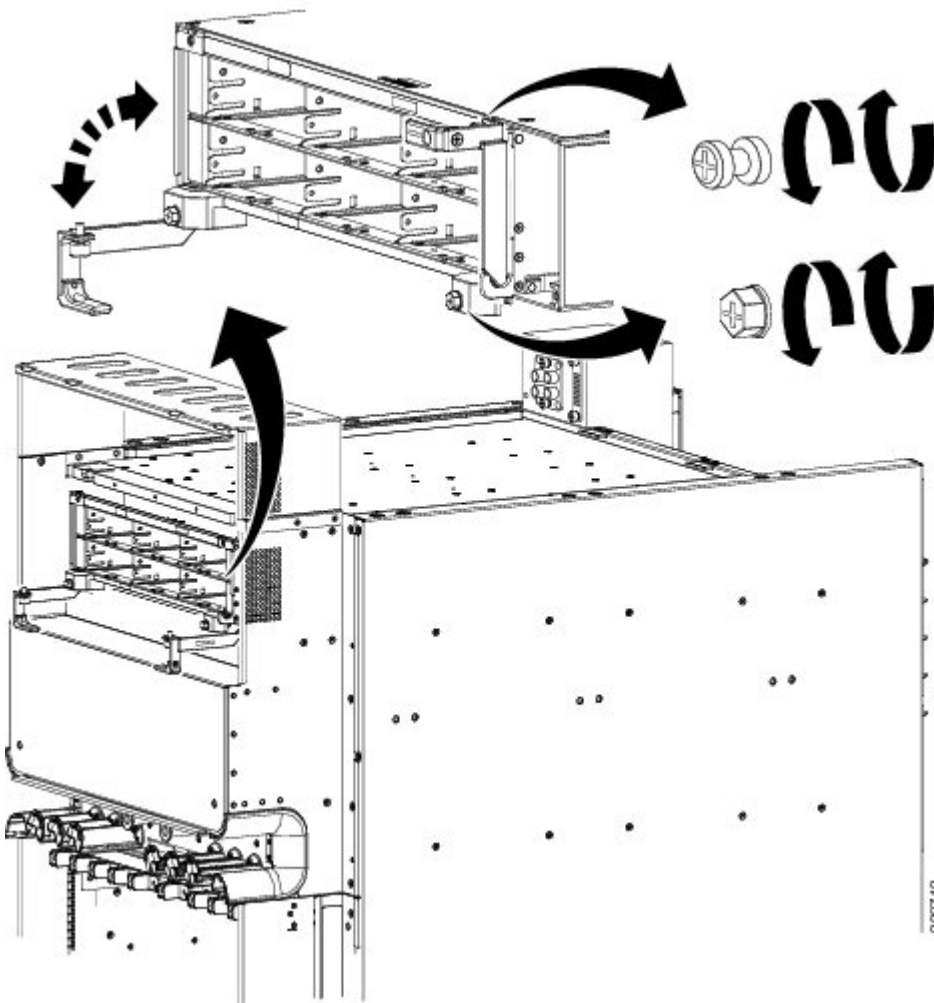
#### SUMMARY STEPS

1. Using the screwdriver, remove the screws that secure the bottom of the power shelves to the chassis. There is one screw on each side of the power shelf.
2. Using the screwdriver, loosen the captive screws on the power shelf handles on the power shelf. Each power shelf handle contains one captive screw. The handles will fall down away from the shelf, as shown in the following image.
3. Grasping both handles simultaneously, pull both the left and right handles down and out at the same time to pull the shelf partially out of the chassis.
4. When the shelf is partially out of the chassis and the ejector handles are away from the pins, rotate the handles back up to the closed position and hand-tighten the handle screws back into the shelf.
5. Using two people, one to support the power shelf underneath and the other to keep it steady, slide the shelf out of the chassis, and carefully set it down on a flat surface.
6. Remove the second power shelf, if necessary, by following step 1 through step 5.

## DETAILED STEPS

- Step 1** Using the screwdriver, remove the screws that secure the bottom of the power shelves to the chassis. There is one screw on each side of the power shelf.
- Note** If you are removing both power shelves from the chassis, you can remove the power shelves in any order that you prefer. Ensure that the first power shelf is fully removed from the chassis before attempting to remove the second power shelf.
- Step 2** Using the screwdriver, loosen the captive screws on the power shelf handles on the power shelf. Each power shelf handle contains one captive screw. The handles will fall down away from the shelf, as shown in the following image.

*Figure 126: Removing Power Shelf from Chassis*



205F12

- Step 3** Grasping both handles simultaneously, pull both the left and right handles down and out at the same time to pull the shelf partially out of the chassis.
- Step 4** When the shelf is partially out of the chassis and the ejector handles are away from the pins, rotate the handles back up to the closed position and hand-tighten the handle screws back into the shelf.
- Step 5** Using two people, one to support the power shelf underneath and the other to keep it steady, slide the shelf out of the chassis, and carefully set it down on a flat surface.
- Caution** Because of the weight of the power shelf, 40 lbs (18 kg), and the height that the power shelf is installed in the chassis, you should be especially careful while lifting and removing the power shelf. To prevent injury, keep your back straight and lift with your legs, not your back. Avoid sudden twists or lateral moves.
- Step 6** Remove the second power shelf, if necessary, by following step 1 through step 5.
- 

## What to Do Next

After performing this task, install a replacement power shelf, if necessary, (see the [Installing an AC or DC Power Shelf](#), on page 42), and replace the upper grille on the front (PLIM) and rear (MSC) sides of the chassis.

## Removing the Upper Grille Support

This section describes how to remove the upper grille support from the Cisco CRS enhanced 16-slot line card chassis. For complete information on regulatory compliance and safety, see *Regulatory Compliance and Safety Information for the Cisco CRS Carrier Routing System*.

### Prerequisites

Before performing this task, remove the upper grilles from the front (PLIM) and rear (MSC) sides of the chassis (if installed), the AC or DC PMs, alarm module, and the AC or DC input power wiring, and the power shelves from the chassis. For more information, see the following sections:

### Required Tools and Equipment

You need the following tool to perform this task:

- 6-in. long number 1 Phillips screwdriver

### Steps

To remove the upper grille support from the chassis, perform the following steps:

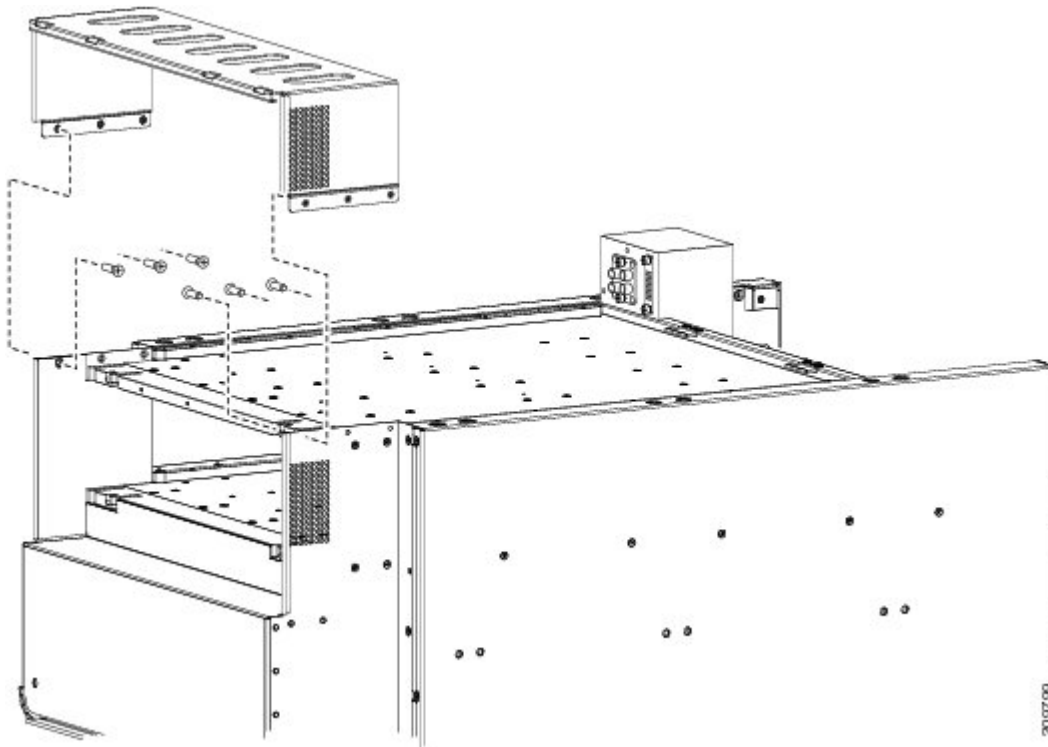
#### SUMMARY STEPS

1. Use the screwdriver to remove the six M4 flat head screws, three on each side, that attach the upper grille support to the chassis.
2. Remove the upper grille support from the front of the chassis, and set it aside.

## DETAILED STEPS

- Step 1** Use the screwdriver to remove the six M4 flat head screws, three on each side, that attach the upper grille support to the chassis.

**Figure 127: Removing the Upper Grille Support from the Chassis**



- Step 2** Remove the upper grille support from the front of the chassis, and set it aside.

## Removing the Chassis Ground Cable

This section describes how to remove the chassis ground cable on the Cisco CRS enhanced 16-slot line card chassis. For complete information on regulatory compliance and safety, see *Regulatory Compliance and Safety Information for the Cisco CRS Carrier Routing System*.

### Prerequisites

Before performing this task, remove the AC or DC input power wiring from both power shelves, and remove both power shelves from the chassis.



**Caution**

---

Do not remove the chassis ground cable unless the chassis is being replaced.

---

## Required Tools and Equipment

You need the following tools and equipment to perform this task:

- 3/8 in. drive socket wrench
- 10-mm 6 pt. socket wrench

## Steps

To remove the ground cable from the chassis, perform the following steps:

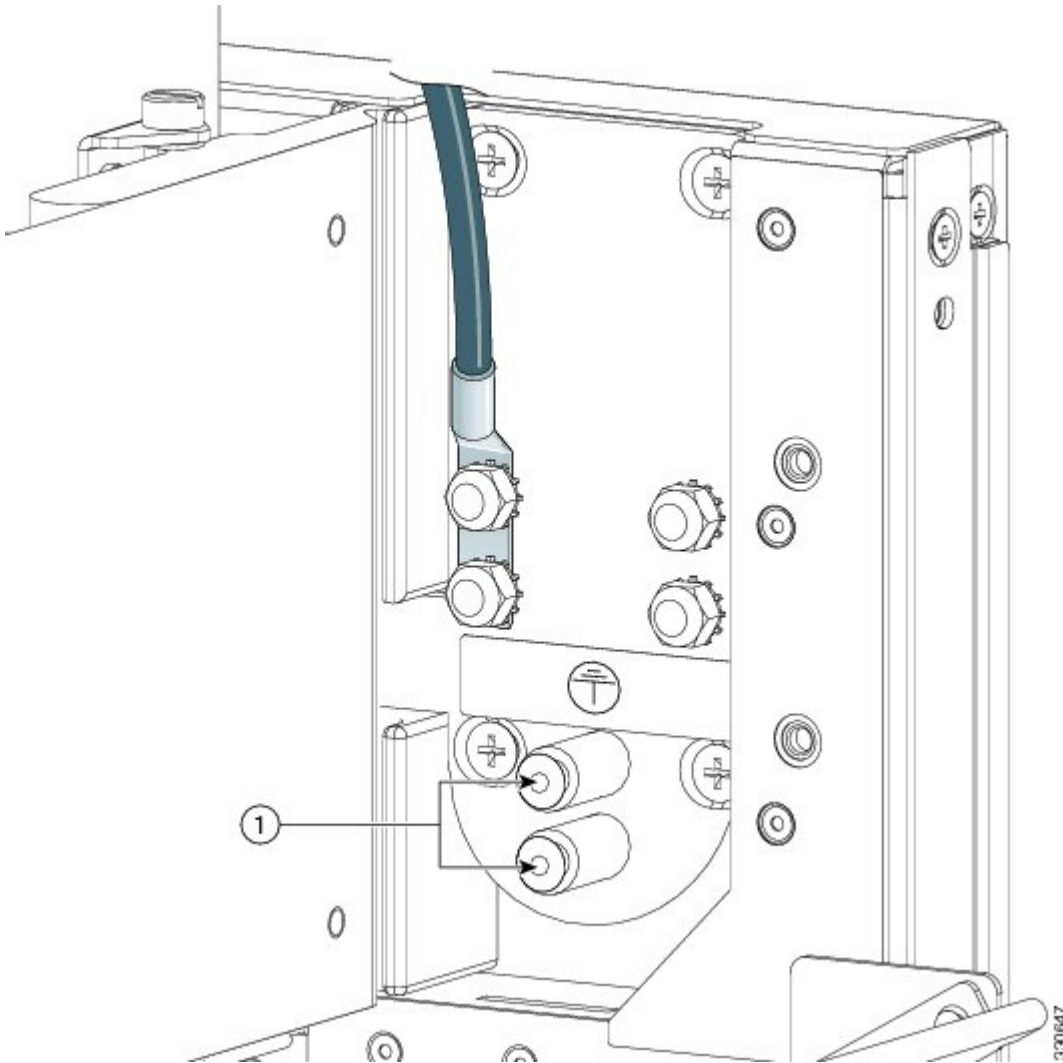
### SUMMARY STEPS

1. If the ground cable is connected to the grounding point at the top of the chassis, use the 10-mm wrench to remove the two M6 bolts that attach the ground cable to the grounding point, as shown in the following image.
2. If the ground cable is connected to the grounding point at the bottom of the chassis, use the 10-mm wrench to remove the two M6 nuts that secure the ground cable to the grounding point.

## DETAILED STEPS

- Step 1** If the ground cable is connected to the grounding point at the top of the chassis, use the 10-mm wrench to remove the two M6 bolts that attach the ground cable to the grounding point, as shown in the following image.

*Figure 128: NEBS Bonding and Grounding Point—Top of Chassis*

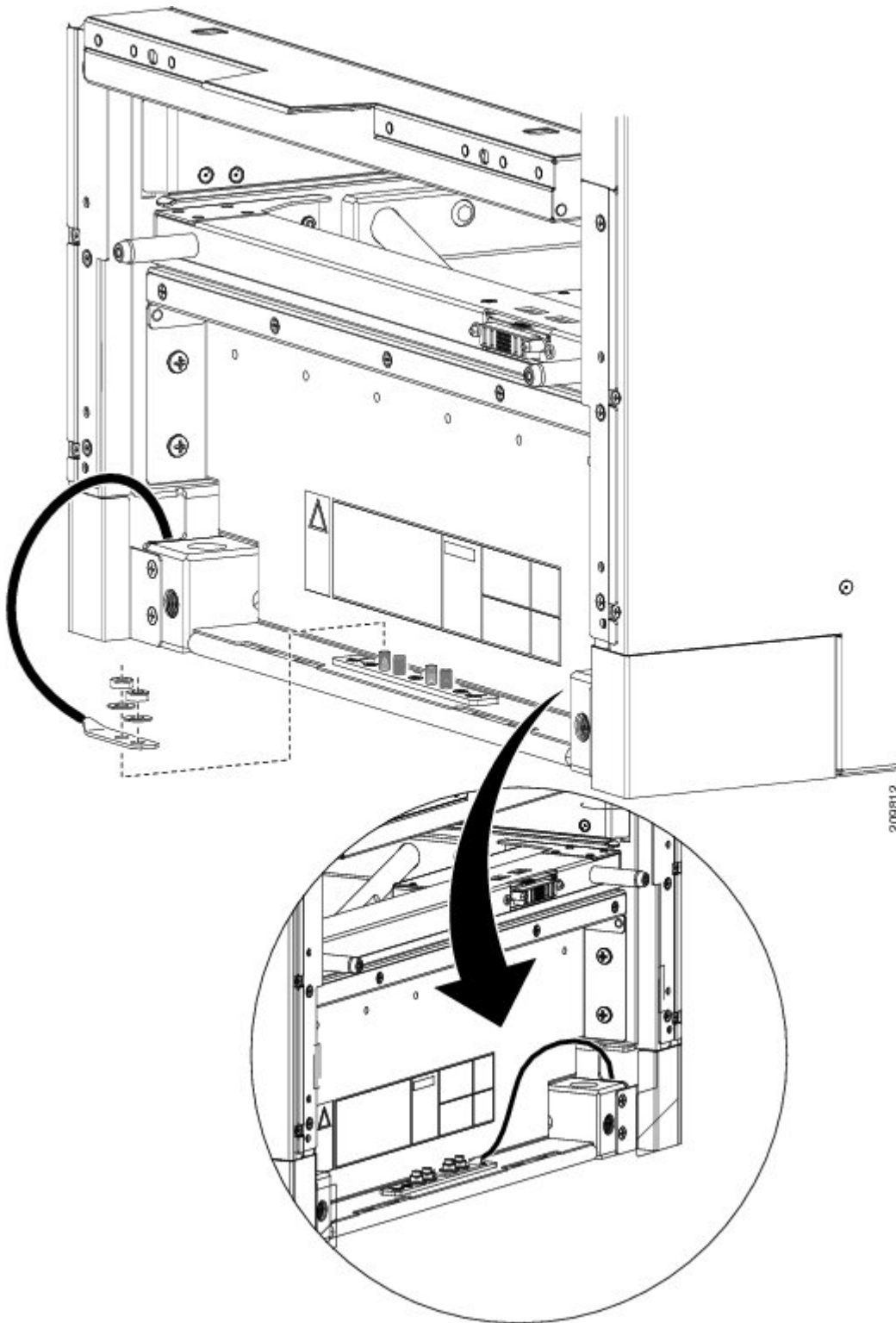


1

Two Torx security screws (Do not remove)

- Step 2** If the ground cable is connected to the grounding point at the bottom of the chassis, use the 10-mm wrench to remove the two M6 nuts that secure the ground cable to the grounding point.

*Figure 129: NEBS Bonding and Grounding Point—Bottom of Chassis*



## Disconnecting the Power A Bus Bar

This section describes how to disconnect the Power A bus bar from the rear of the Cisco CRS enhanced 16-slot line card chassis.

### Prerequisites

Before performing this task, remove all power components, including alarm modules, power modules, DC wiring or AC cables, and both power shelves from the chassis.

### Required Tools and Equipment

You need the following tool to perform this task:

- 6-in. long number 1 Phillips screwdriver
- Power A bus bar shipping bracket

### Steps

To disconnect the Power A bus bar, perform the following steps:

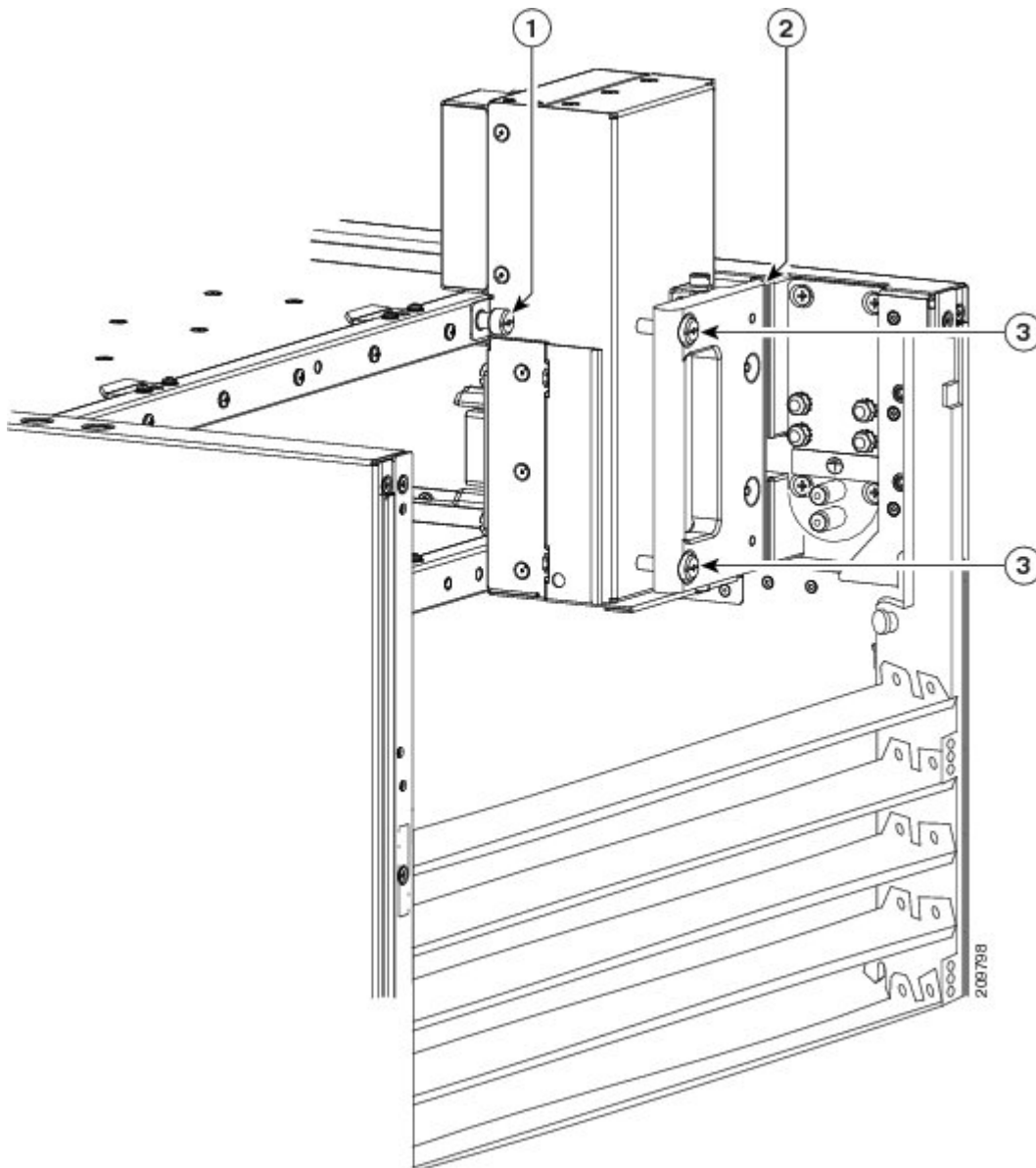
#### SUMMARY STEPS

1. Loosen the Phillips captive screw that secures the Power A bus bar to the chassis. The screw is located on the tab on the left side of the power bus bar.
2. Loosen the two captive screws on the Power A bus bar handle.
3. Remove the Power A bus bar from where it is seated.
4. Carefully secure the Power A bus bar to the chassis frame in a horizontal position by re-installing the shipping bracket. Tighten the six captive screws that attach the shipping bracket to the rear of the chassis.

## DETAILED STEPS

- Step 1** Loosen the Phillips captive screw that secures the Power A bus bar to the chassis. The screw is located on the tab on the left side of the power bus bar.

*Figure 130: Power A Bus Bar Installed in Chassis*



1	Screw securing Power A bus bar to chassis
2	Pivot point

3	Two screws securing handle to Power A bus bar
---	---

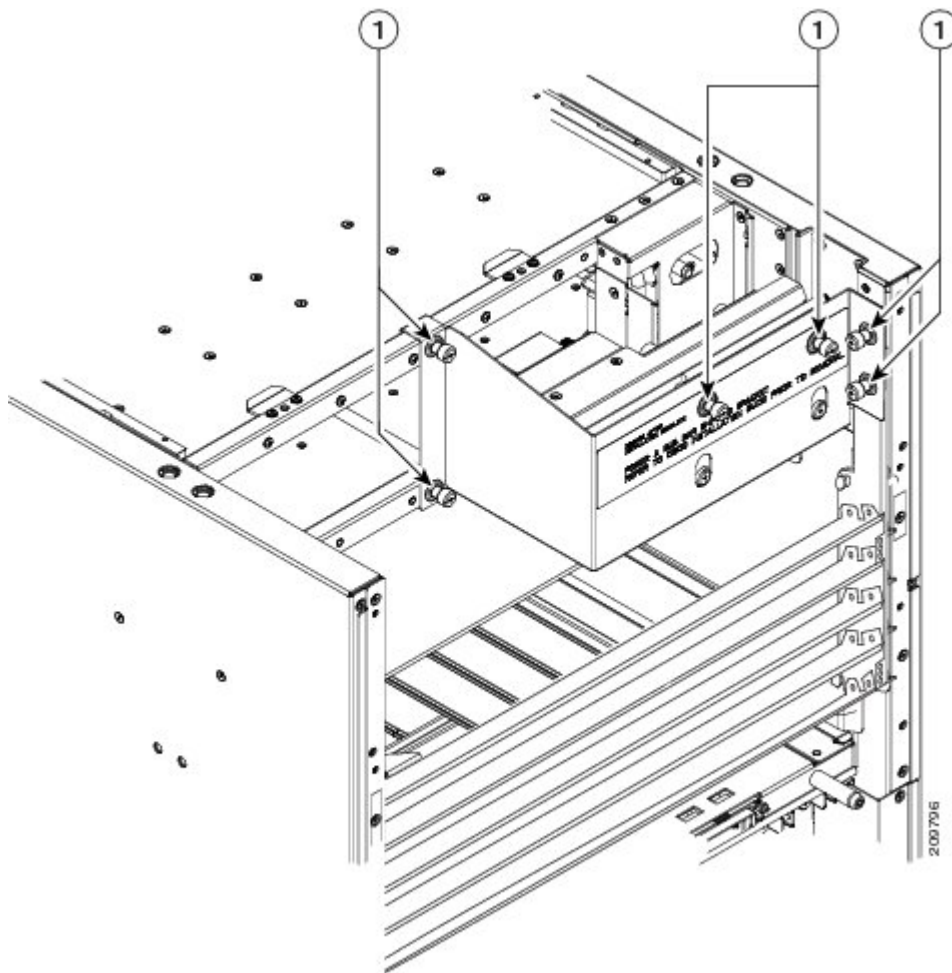
**Step 2** Loosen the two captive screws on the Power A bus bar handle.

**Step 3** Remove the Power A bus bar from where it is seated.

**Note** The Power A bus bar is connected to the chassis with an internal cable. Be careful not to drop the power bus bar.

**Step 4** Carefully secure the Power A bus bar to the chassis frame in a horizontal position by re-installing the shipping bracket. Tighten the six captive screws that attach the shipping bracket to the rear of the chassis.

**Figure 131: Installing the Power A Bus Bar Shipping Bracket**



1	Captive screws securing Power A bus bar bracket to chassis rear
---	---

# Converting from One Power System to the Other

This section describes how to convert from one power system to another (either from AC to DC, or from DC to AC). For complete information on regulatory compliance and safety, see *Regulatory Compliance and Safety Information for the Cisco CRS Carrier Routing System*.

## Steps

To convert a Cisco CRS Series Enhanced 16-slot Line Card Chassis with a power system from AC to DC power, or from DC to AC power, perform the following steps:

### SUMMARY STEPS

1. Power down the chassis completely. See [Power Down a Chassis](#), on page 71
2. Remove the AC or DC PMs. See [Removing a Power Module](#), on page 221.
3. Remove the alarm modules. See [Removing an Alarm Module](#), on page 222.
4. Unplug the AC power cords or remove the DC fusing from the power source. Remove the AC or DC wiring from the rear of the power shelf. See [Removing AC or DC Power Shelf Wiring](#), on page 227.
5. Remove the power shelves. See [Removing a Power Shelf](#), on page 231.
6. Install the new power shelves. See [Installing an AC or DC Power Shelf](#), on page 42.
7. Install the power shelf wiring. See [Installing AC or DC Power Shelf Wiring](#), on page 48 .
8. Install the alarm modules. See [Installing an Alarm Module](#), on page 58.
9. Install the AC or DC PMs. See [Installing a Power Module](#), on page 63.
10. Power the chassis back up. See [Power Up and Power Down a Chassis](#), on page 68 .

### DETAILED STEPS

- 
- Step 1** Power down the chassis completely. See [Power Down a Chassis](#), on page 71
- Step 2** Remove the AC or DC PMs. See [Removing a Power Module](#), on page 221.
- Step 3** Remove the alarm modules. See [Removing an Alarm Module](#), on page 222.
- Step 4** Unplug the AC power cords or remove the DC fusing from the power source. Remove the AC or DC wiring from the rear of the power shelf. See [Removing AC or DC Power Shelf Wiring](#), on page 227.
- Step 5** Remove the power shelves. See [Removing a Power Shelf](#), on page 231.
- Step 6** Install the new power shelves. See [Installing an AC or DC Power Shelf](#), on page 42.
- Step 7** Install the power shelf wiring. See [Installing AC or DC Power Shelf Wiring](#), on page 48 .

**Note** If you are converting from DC to AC power, and if you have AC Delta or AC Wye at your equipment, a *Cisco CRS PDU* will be required to convert 3-phase AC input power to single-phase AC input power for the power shelf. For further information and installation instructions, refer to [Cisco CRS 3-Phase AC Power Distribution Unit Installation Guide](#).



- Step 8** Install the alarm modules. See [Installing an Alarm Module](#), on page 58.
- Step 9** Install the AC or DC PMs. See [Installing a Power Module](#), on page 63.
- Step 10** Power the chassis back up. See [Power Up and Power Down a Chassis](#), on page 68 .
- 

### What to Do Next

**Note**

Use only one type of power shelf—AC or DC—and its mating AC or DC PM in a chassis at one time.

---

## What to Do Next

Be sure that all parts have been carefully set aside and repackaged appropriately.





## Upgrading Chassis Components

This chapter provides instructions on how to upgrade chassis components on the Cisco CRS 16-slot enhanced line card chassis.

This chapter presents the following topics:

- [Upgrading the Inlet Grille Screen, page 245](#)
- [Installing the Exhaust Baffle, page 250](#)

### Upgrading the Inlet Grille Screen

To ensure protection against debris getting through the lower grille and into the chassis bay, Cisco Systems provides a screen that you can install behind the lower grille.

This section describes how to install the inlet grille screen in the Cisco CRS Carrier Routing System 16-slot EC line card chassis.

To install the inlet grille screen kit (CRS-16-SCREEN-KIT) as an update to an existing system, you must:

- 1 Remove the lower grille from the front (PLIM) side of the chassis.
- 2 Remove the lower grille frame assembly that is currently installed.
- 3 Install the new lower grille screen and frame assembly.
- 4 Re-install the original lower grille on the front (PLIM) side of the chassis.

### Required Tools and Equipment

You need the following tools and parts to perform this task:

- 8 in. long number 1 Phillips screwdriver—magnetic head preferable
- Lower grille screen and frame assembly
- Lower grille screen kit (Cisco product number: CRS-16-SCREEN-KIT)

## Removing the Currently Installed Front Inlet Grille

This section describes how to remove the currently installed front lower grille from the chassis.

### Prerequisites

There are no prerequisites for this task.

### Steps

To remove the front inlet grille from the chassis, perform the following steps:

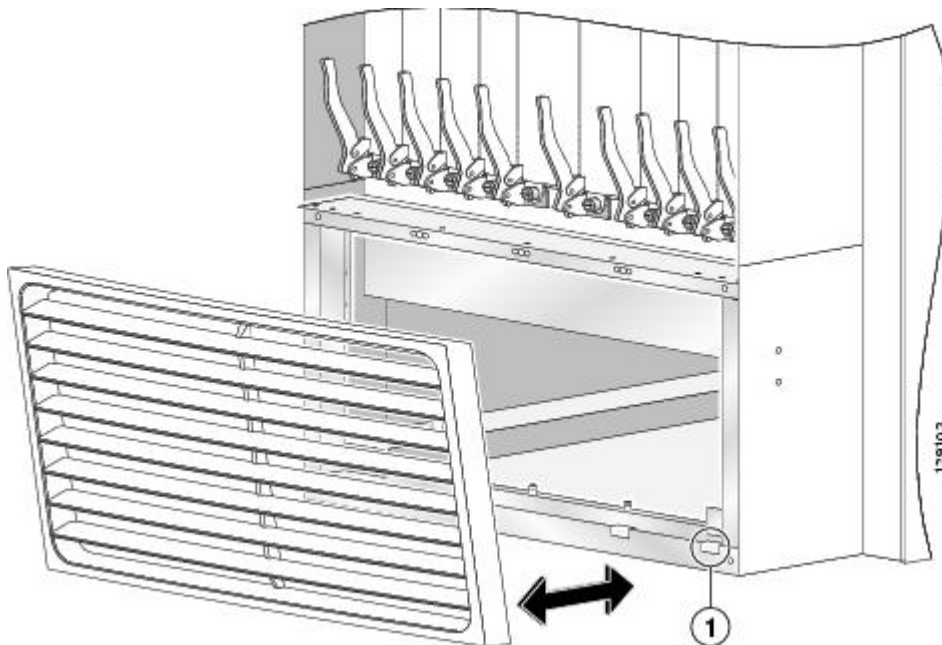
### SUMMARY STEPS

1. Remove the inlet grille by unsnapping the top portion from the ball stud snaps (see below).
2. Rotate the grille toward you on its hook hanger brackets, then lift it clear of the support, and set it carefully aside for later use.

### DETAILED STEPS

**Step 1** Remove the inlet grille by unsnapping the top portion from the ball stud snaps (see below).

*Figure 132: Removing the Front Inlet Grille*



1

Hook hanger brackets

- Step 2** Rotate the grille toward you on its hook hanger brackets, then lift it clear of the support, and set it carefully aside for later use.
- 

## Removing the Currently Installed Inlet Grille Frame Assembly

Now that the inlet grille has been removed, you must remove the lower grille frame assembly.

### Prerequisites

Before performing this task, ensure that the lower grille has been removed from the front (PLIM) side of the chassis. See the [Removing the Currently Attached Upper Rear Grille](#), on page 252 for more information.

### Steps

To remove the currently installed lower grille frame assembly, perform the following steps:

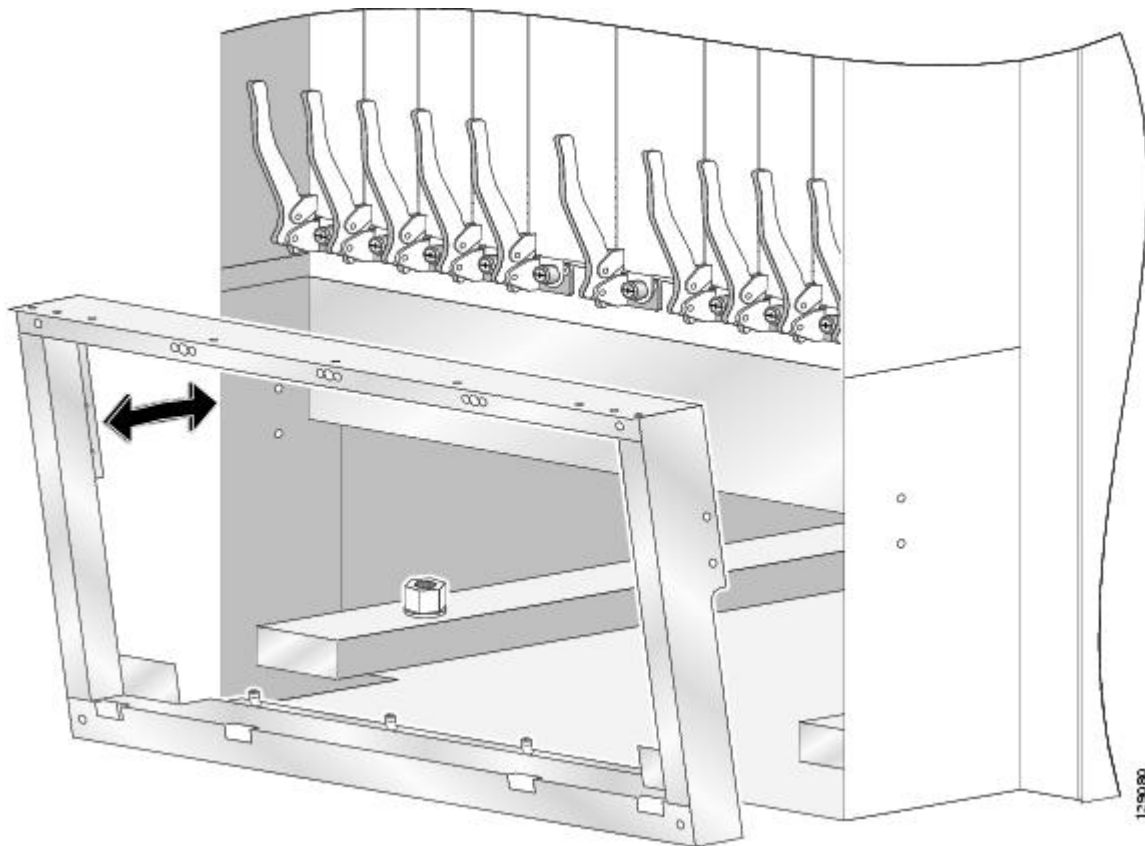
### SUMMARY STEPS

1. Use the Phillips screwdriver to unscrew the four captive screws, two on each side, that attach the inlet grille frame assembly to the chassis (see below).
2. Rotate the assembly forward, lift it away from the chassis, and set it aside.

## DETAILED STEPS

- Step 1** Use the Phillips screwdriver to unscrew the four captive screws, two on each side, that attach the inlet grille frame assembly to the chassis (see below).

*Figure 133: Removing the Inlet Grille Frame Assembly*



- Step 2** Rotate the assembly forward, lift it away from the chassis, and set it aside.

## Installing the Inlet Grille Frame Assembly and Inlet Screen

This section describes how to install the new inlet grille frame assembly and the inlet grille screen.

In this task, you must first remove the lower grille screen from the frame, because the screws that attach the frame assembly to the chassis are inboard of the screen—that is, the new screen is shipped already installed into the new frame assembly, but you cannot attach the new frame to the chassis until you remove the screen first. When the new frame assembly is installed, you can reinstall the lower grille screen into the new frame.

### Prerequisites

Before performing this task, ensure that the lower grille and lower grille frame assembly have been removed. See the and the [Removing the Currently Installed Inlet Grille Frame Assembly, on page 247](#) for more information.

### Steps

To install the new inlet grille frame and screen, perform the following steps:

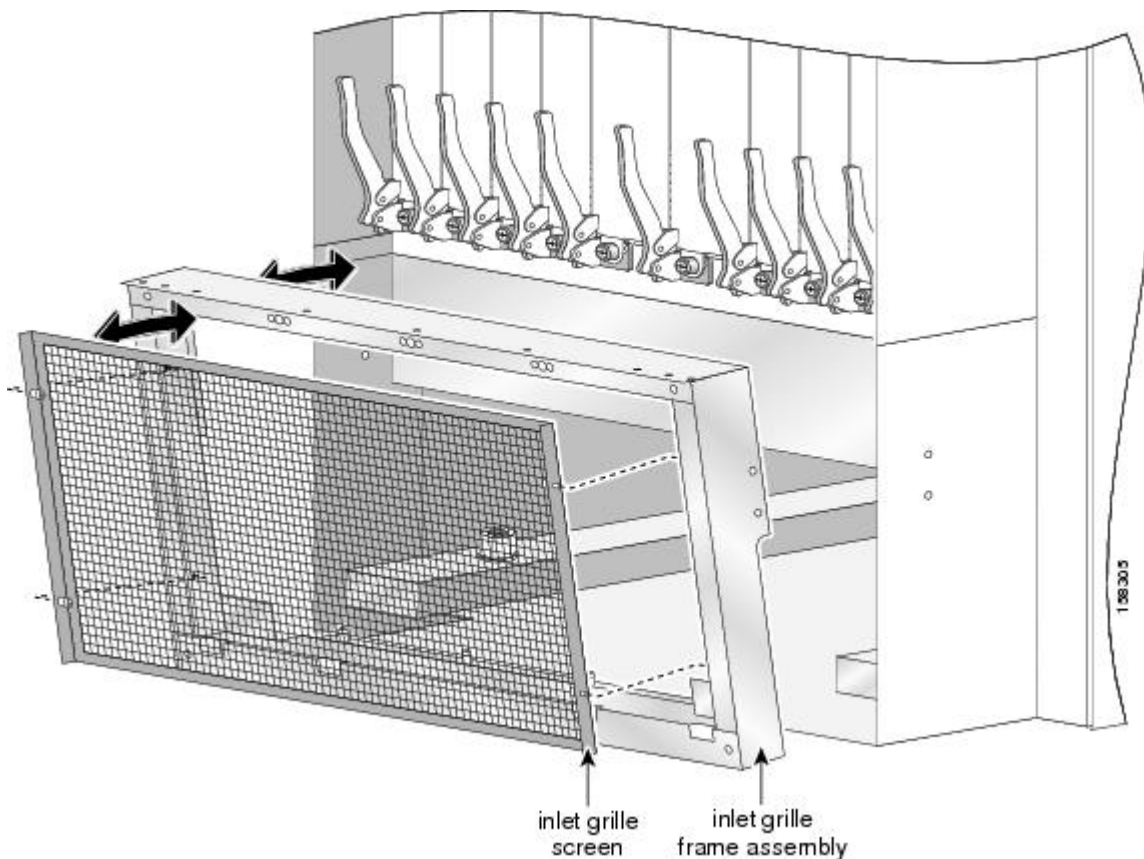
### SUMMARY STEPS

1. Use the Phillips screwdriver to remove the four screws, two on each side, that secure the inlet grille screen to its frame assembly; then carefully set the screen aside.
2. Install the inlet grille fragment assembly (see Figure 8-3) by aligning the four screws, two on each side, on the frame to the screw holes on the chassis and tightening them with the screwdriver.
3. Attach the inlet grille screen (see Figure 8-3) to the frame assembly by aligning the four captive screws on the screen to the screw holes on the frame assembly and tightening the screws with the screwdriver.
4. Attach the inlet grille by carefully inserting the tabs on the grille into the hook hanger brackets on the inlet grille frame.
5. Press the grille firmly against the grille frame until it snaps onto the ball stud snaps.

## DETAILED STEPS

- Step 1** Use the Phillips screwdriver to remove the four screws, two on each side, that secure the inlet grille screen to its frame assembly; then carefully set the screen aside.

*Figure 134: Inlet Grille Screen and the Frame Assembly*



- Step 2** Install the inlet grille fragment assembly (see Figure 8-3) by aligning the four screws, two on each side, on the frame to the screw holes on the chassis and tightening them with the screwdriver.
- Step 3** Attach the inlet grille screen (see Figure 8-3) to the frame assembly by aligning the four captive screws on the screen to the screw holes on the frame assembly and tightening the screws with the screwdriver.
- Step 4** Attach the inlet grille by carefully inserting the tabs on the grille into the hook hanger brackets on the inlet grille frame.
- Step 5** Press the grille firmly against the grille frame until it snaps onto the ball stud snaps.

## Installing the Exhaust Baffle

This section describes the procedure for installing the new exhaust baffle.



Installing the exhaust baffle and the rear louver grille is necessary only if you have ordered the exhaust baffle and louver grille as an upgrade to your existing Cisco CRS Carrier Routing System 16-slot EC line card chassis. New systems ship with the exhaust baffle pre installed.

**Note**

---

The rear louver grille (with the internal grille) should always be used with the internal baffle installed. Using the new rear grille without the exhaust baffle causes degradation of the system thermal performance.

---

The new air exhaust components redirect the airflow from the back of the Cisco CRS Carrier Routing System 16-slot EC line card chassis away from eye level. This air exhaust redirection provides a more comfortable work environment if any work needs to be done in the back of the Cisco CRS Carrier Routing System 16-slot EC line card chassis while it is operational.

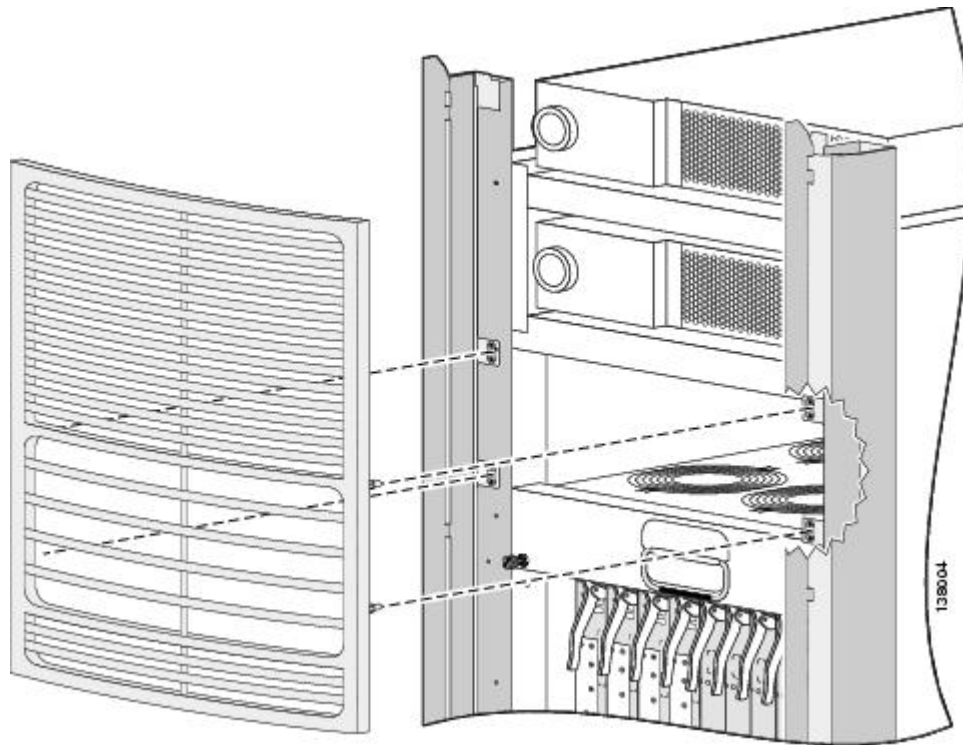
The main tasks for this procedure are:

- Remove the currently attached upper rear grille.
- Remove the upper fan tray.
- Install the exhaust baffle.
- Reinstall the fan tray.

## Removing the Currently Attached Upper Rear Grille

This section describes how to remove the upper rear grille (see Figure 8-4) that is currently attached to the Cisco CRS Carrier Routing System 16-slot EC line card chassis so that you can replace it with the updated louver grille.

**Figure 135: Removing the Upper Rear Grille—Fixed Configuration Power Shown**



### Prerequisites

Ensure that *all* power to the Cisco CRS Carrier Routing System 16-slot EC line card chassis is OFF prior to initiating the tasks to install the exhaust baffle.

### Steps

To remove the currently attached upper rear grille (see [Figure 135: Removing the Upper Rear Grille—Fixed Configuration Power Shown](#), on page 252), follow these steps:

## SUMMARY STEPS

1. Remove the upper grille by unsnapping the bottom portion from the ball stud snaps on the vertical mounting brackets.
2. Rotate the grille toward you on its hook hanger brackets, and then lift it clear of the brackets.
3. Set it carefully aside.
4. Be sure that all parts have been carefully set aside and repackaged appropriately.

## DETAILED STEPS

- 
- |               |  |
|---------------|--|
| <b>Step 1</b> | Remove the upper grille by unsnapping the bottom portion from the ball stud snaps on the vertical mounting brackets. |
| <b>Step 2</b> | Rotate the grille toward you on its hook hanger brackets, and then lift it clear of the brackets.                    |
| <b>Step 3</b> | Set it carefully aside.  |
| <b>Step 4</b> | Be sure that all parts have been carefully set aside and repackaged appropriately.                                   |
- 

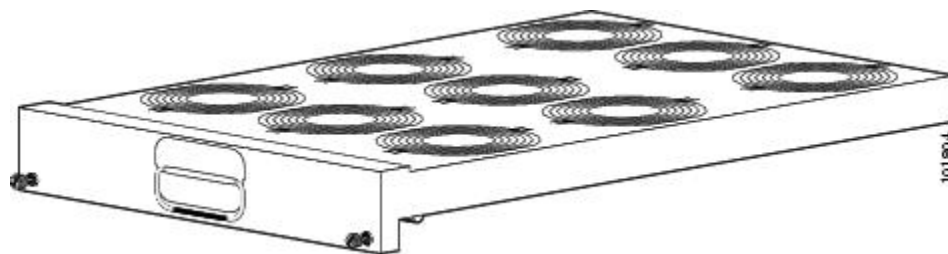
## What to Do Next

The next task is to remove the upper rear fan tray as described in the next section.

## Removing the Upper Fan Tray

This section describes how to remove the upper fan tray (see Figure below) from the Cisco CRS Carrier Routing System 16-slot EC line card chassis.

*Figure 136: Fan Tray*



## Prerequisites

Before performing this task, you must first remove the upper rear grille as described in the previous section.

## Required Tools and Equipment

You need the following tools to perform this task:

- ESD-preventive wrist strap
- Large flat head screwdriver
- Step platform

## Steps

To remove the upper fan tray, follow these steps:

### SUMMARY STEPS

1. Attach the ESD-preventive wrist strap to your wrist and connect its leash to one of the ESD connection sockets on the front (PLIM) side of the chassis or a bare metal surface on the chassis.
2. If necessary, use a step platform to reach the upper fan tray comfortably.
3. Using the screwdriver, loosen the two captive screws on the fan tray cover faceplate.
4. Pull firmly on the cover to swing it free; some force may be required, as the rubber seals can stick.
5. Grasp the fan tray handle and pull it straight out to disconnect the fan tray from the connector mounted on the front of the fan tray bay on the rear (MSC) side of the chassis. Slide the fan tray halfway from the fan tray bay.
6. Use your free hand to support the fan tray, then slide the fan tray completely from the fan tray bay.
7. Set the fan tray carefully aside.

### DETAILED STEPS

- 
- Step 1** Attach the ESD-preventive wrist strap to your wrist and connect its leash to one of the ESD connection sockets on the front (PLIM) side of the chassis or a bare metal surface on the chassis.
- Step 2** If necessary, use a step platform to reach the upper fan tray comfortably.
- Step 3** Using the screwdriver, loosen the two captive screws on the fan tray cover faceplate.
- Step 4** Pull firmly on the cover to swing it free; some force may be required, as the rubber seals can stick.  
**Caution** A fan tray weighs approximately 44 lbs (20 kg); use two hands when handling it.
- Step 5** Grasp the fan tray handle and pull it straight out to disconnect the fan tray from the connector mounted on the front of the fan tray bay on the rear (MSC) side of the chassis. Slide the fan tray halfway from the fan tray bay.
- Step 6** Use your free hand to support the fan tray, then slide the fan tray completely from the fan tray bay.
- Step 7** Set the fan tray carefully aside.
- 

## What to Do Next

You are now ready to install the exhaust baffle, as described in the next section.

## Installing the Exhaust Baffle

The new air exhaust components—the exhaust baffle and the rear louver grille (Product Number: CRS-16-LCC-R-GRL=)—redirect the airflow from the back of the Cisco CRS Carrier Routing System 16-slot EC line card chassis away from eye level. This air exhaust redirection provides a more comfortable work environment if any work needs to be done in the back of the Cisco CRS Carrier Routing System 16-slot EC line card chassis while it is operational.

### Prerequisites

Before performing this task, you must first remove the upper rear grille upper fan tray as described in the previous sections.

### Required Tools and Equipment

You need the following tools and components to perform this task:

- ESD-preventive wrist strap
- Cisco CRS Grille Kit: CRS-16-LCC-R-GRL=
- Number 1 flat-head screwdriver with at least a 9-inch shaft
- Step platform

### Steps

To install the exhaust baffle, follow these steps:

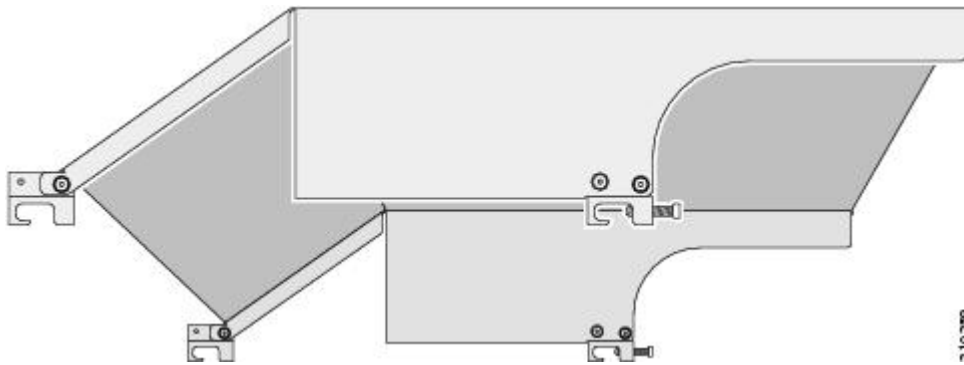
#### SUMMARY STEPS

1. Attach the ESD-preventive wrist strap to your wrist and connect its leash to one of the ESD connection sockets on the rear side of the chassis.
2. If necessary, use a step platform to reach the upper fan tray comfortably.
3. Observe the four retention brackets at the front and rear of the exhaust baffle (see figure below).
4. Using both hands, lift the exhaust baffle and insert it into the open bay as shown below.
5. Align the rear retention brackets directly over the third rivets from the rear of the chassis (see figure below); then let the exhaust baffle drop down over the rivets.
6. Pull the exhaust baffle toward you to make the retention brackets snug against the rivets.
7. To secure the exhaust baffle to the chassis, use the 9-inch Number 1 flat-blade screwdriver to tighten the four retention bracket screws (see figure below).

## DETAILED STEPS

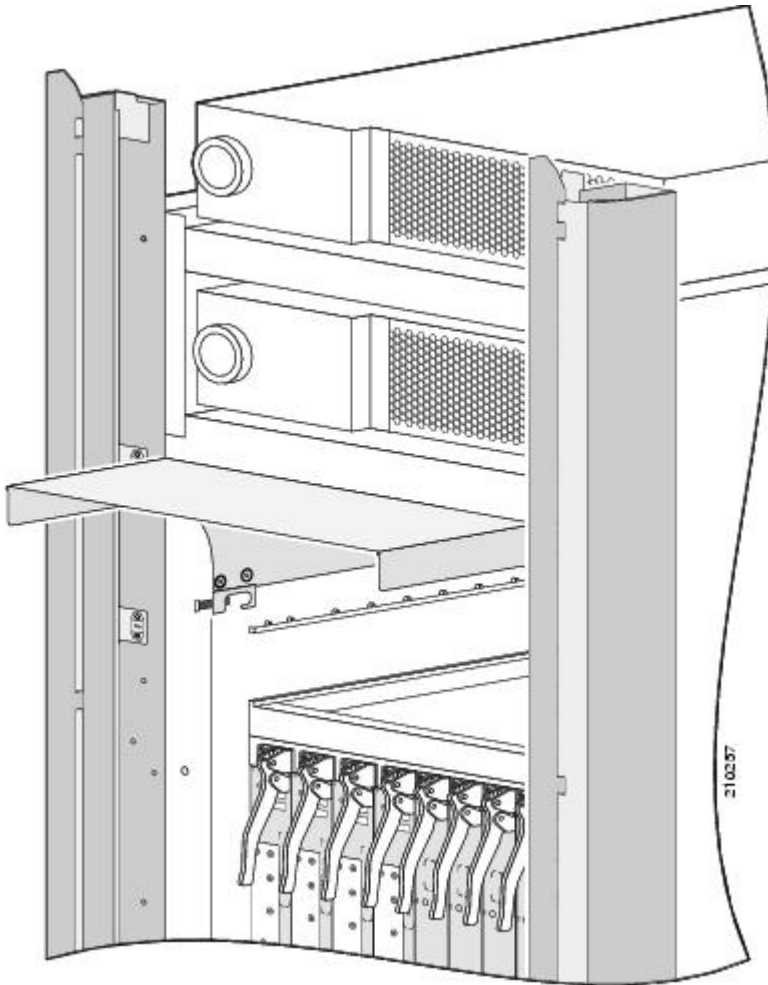
- Step 1** Attach the ESD-preventive wrist strap to your wrist and connect its leash to one of the ESD connection sockets on the rear side of the chassis.
- Step 2** If necessary, use a step platform to reach the upper fan tray comfortably.
- Step 3** Observe the four retention brackets at the front and rear of the exhaust baffle (see figure below).

**Figure 137: Exhaust Baffle and Retention Brackets**



**Step 4** Using both hands, lift the exhaust baffle and insert it into the open bay as shown below.

**Figure 138: Inserting the Exhaust Baffle into the Chassis Bay—Fixed Configuration Power Shown**

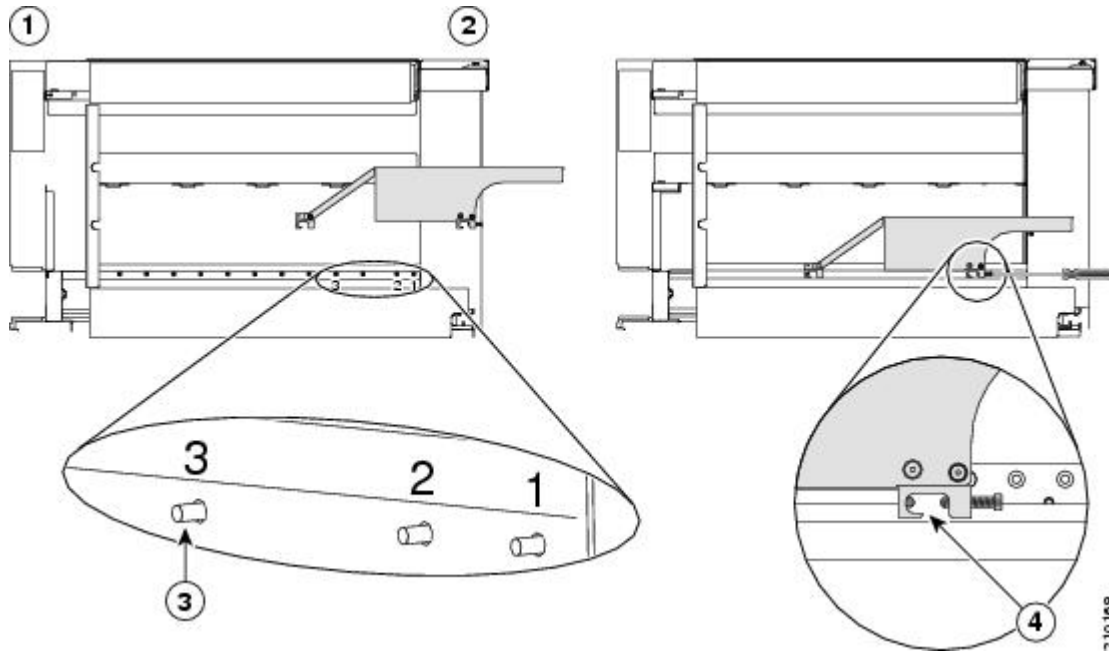


Observe the rivets on both sides of the open bay.

**Step 5** Align the rear retention brackets directly over the third rivets from the rear of the chassis (see figure below); then let the exhaust baffle drop down over the rivets.

**Note** The front retention brackets will drop into the appropriate rivets.

**Figure 139: Fitting the Baffle Retention Brackets Over the Rivets**



1	Front of chassis	2	Rear of chassis
3	Third rivet from the rear of the chassis, upon which the exhaust baffle rests	4	Exhaust baffle retention bracket sits down on the rivet

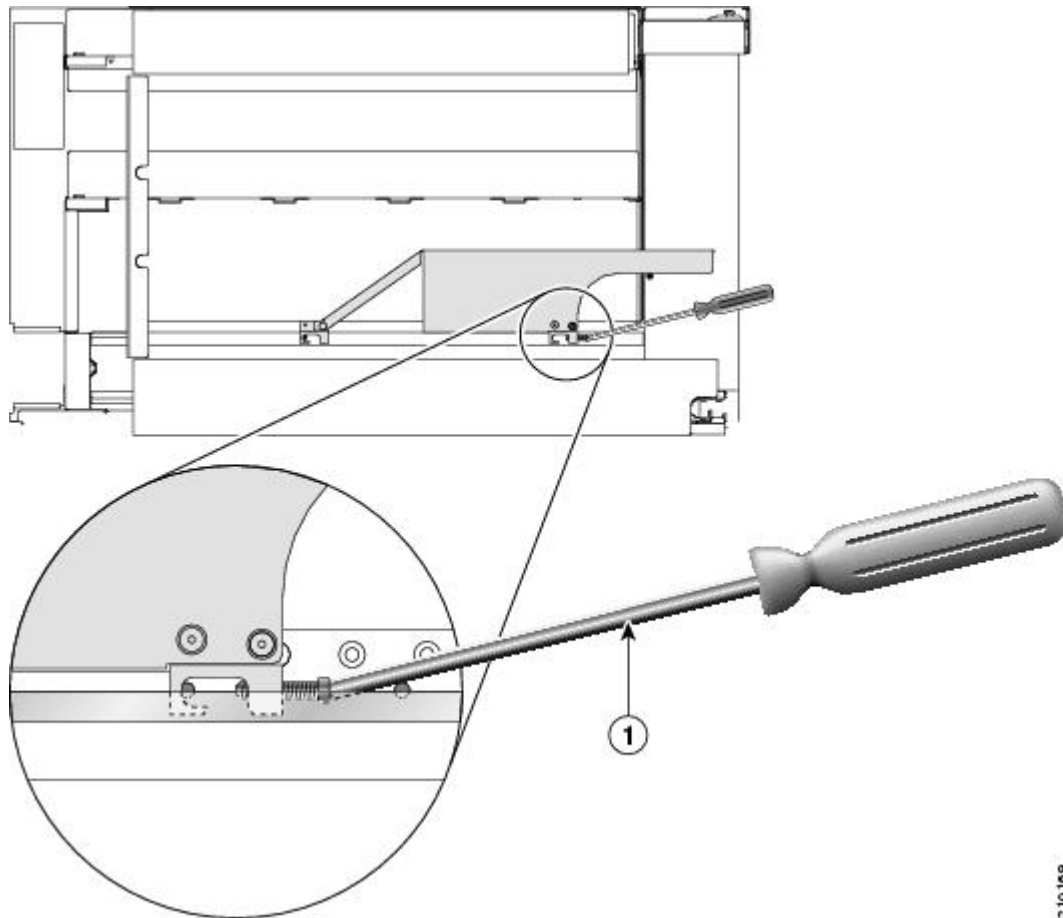
**Step 6** Pull the exhaust baffle toward you to make the retention brackets snug against the rivets.

**Step 7** To secure the exhaust baffle to the chassis, use the 9-inch Number 1 flat-blade screwdriver to tighten the four retention bracket screws (see figure below).



**Tip** Continue to pull the exhaust baffle toward you while you tighten the retention bracket screws.

**Figure 140: Securing the Exhaust Baffle to the Chassis**



1	Tightening retention bracket screw with 9-inch flat screwdriver
---	---

The exhaust baffle is now installed. You can now reinstall the upper fan tray.

## What to Do Next

Reinstall the fan tray, as described in the next section.

## Reinstalling the Upper Fan Tray

This section describes how to reinstall the upper fan tray in the Cisco CRS Carrier Routing System 16-slot EC line card chassis.

### Prerequisites

Before performing this task, make sure the exhaust baffle is correctly and securely installed.

### Required Tools and Equipment

You need the following tools and part to perform this task:

- ESD-preventive wrist strap
- Large flat-head screwdriver
- Fan tray (Cisco product number CRS-16-LCC-FAN-TR)
- Step platform

### Steps

To install the upper fan tray, follow these steps:

#### SUMMARY STEPS

1. If necessary, use a step platform to reach the upper fan tray comfortably.
2. Attach the ESD-preventive wrist strap to your wrist and connect its leash to one of the ESD connection sockets on the front (PLIM) side of the chassis or a bare metal surface on the chassis.
3. Using two hands to support the fan tray, position it in front of the fan tray bay so that the fan tray connector that is on the back of the fan tray lip is aligned with the connector mounted on the front of the fan tray bay (on the rear side of the chassis).
4. Slide the fan tray into the fan tray bay. Stop when the fan tray makes contact with the chassis connector in the back of the fan tray bay.
5. Firmly push on the fan tray handle to seat the fan tray connector in the chassis connector. When completely seated, the fan tray faceplate flanges meet the front (PLIM) side of the chassis.
6. Replace the fan tray cover and tighten the two captive screws on the fan tray cover faceplate.

## DETAILED STEPS

---

- Step 1** If necessary, use a step platform to reach the upper fan tray comfortably.
- Step 2** Attach the ESD-preventive wrist strap to your wrist and connect its leash to one of the ESD connection sockets on the front (PLIM) side of the chassis or a bare metal surface on the chassis.
- Step 3** Using two hands to support the fan tray, position it in front of the fan tray bay so that the fan tray connector that is on the back of the fan tray lip is aligned with the connector mounted on the front of the fan tray bay (on the rear side of the chassis).
- Caution** A fan tray weighs approximately 44 lbs (20 kg); use two hands when handling it.
- Step 4** Slide the fan tray into the fan tray bay. Stop when the fan tray makes contact with the chassis connector in the back of the fan tray bay.
- Caution** To prevent damage to the chassis connector, use firm but not excessive force when inserting a fan tray into its bay.
- Step 5** Firmly push on the fan tray handle to seat the fan tray connector in the chassis connector. When completely seated, the fan tray faceplate flanges meet the front (PLIM) side of the chassis.
- Note** All electrical and control line connections are made automatically when the connectors mate.
- Step 6** Replace the fan tray cover and tighten the two captive screws on the fan tray cover faceplate.
- 

## What to Do Next

Now you can install the upper rear louver grille.





## Cisco CRS 16-Slot EC Line Card Chassis Specifications

---

This appendix contains tables that list the specifications for the main components of the Cisco CRS 16-Slot EC Line Card Chassis.

**Note**

---

For a complete list of cards supported in the LCC, see Cisco Carrier Routing System [Data Sheets](http://www.cisco.com/en/US/products/ps5763/products_data_sheets_list.html) at: [http://www.cisco.com/en/US/products/ps5763/products\\_data\\_sheets\\_list.html](http://www.cisco.com/en/US/products/ps5763/products_data_sheets_list.html).

---

The appendix includes the following topics:

- [Line Card Chassis Specifications, page 263](#)
- [Power Specifications, page 265](#)
- [Line Card Chassis Environmental Specifications, page 267](#)
- [Regulatory, Compliance, and Safety Specifications, page 268](#)

### Line Card Chassis Specifications

Below table lists the specifications for the LCC.

Table 5: Cisco CRS 16-Slot EC Line Card Chassis Specifications

<b>Supported Cards and Modules</b>	<b>16 modular services cards (MSCs), forwarding processor (FP) cards, or label switch processor (LSP) cards (line cards)</b> <b>16 physical layer interface modules (PLIMs), one for each MSC, FP, or LSP</b> <b>8 switch fabric cards (SFCs)</b> <b>2 route processor (RP) cards or 2 performance route processor (PRP) cards</b> <b>2 fan trays</b> <b>1 air filter</b>
Chassis Dimensions	
Height	80 in. (203.2 cm) as shipped 84 in. (213.4 cm) as installed (with two power shelves)
Width	23.6 in. (59.9 cm) (without cosmetics) 36.0 in. (91.5 cm) with PDU and brackets 31.8 in. (80.8 cm) with optional wide cable management troughs
Depth	36 in. (91 cm) without doors and other cosmetics 39.7 in. (101 cm) with front and rear doors 40.3 in. (102.2 cm) with optional wide cable management troughs
Floor space requirement	Chassis: 7.5 sq ft (.7 sq m) Aisle spacing to install chassis (front): 48 in. (122 cm) Aisle spacing to service FRUs (front): 36 in. (91 cm) Aisle spacing to service FRUs (rear): 36 in. (91 cm)
Chassis	
Chassis shipping weight	993 lb (450.42 kg)
Chassis in shipping crate with pallet	1300 lb (589.67 kg)
Chassis with power shelves only, no power modules	1101 lb (499.4 kg)
Chassis with power shelves, power modules, alarm module	1180 lb (535.2 kg)
Chassis, fully loaded with cards, without cosmetics	1535 lb (696.3 kg)
Chassis, fully loaded with cards and cosmetics (doors, panels, grilles, and so on)	1650 lb (748.43 kg)

<b>Supported Cards and Modules</b>	<b>16 modular services cards (MSCs), forwarding processor (FP) cards, or label switch processor (LSP) cards (line cards)</b> <b>16 physical layer interface modules (PLIMs), one for each MSC, FP, or LSP</b> <b>8 switch fabric cards (SFCs)</b> <b>2 route processor (RP) cards or 2 performance route processor (PRP) cards</b> <b>2 fan trays</b> <b>1 air filter</b>
Chassis, fully loaded with cards and cosmetics (doors, panels, grilles, and so on), AC Wye PDU, and brackets	1720.7 lb (780.5 kg)
Chassis, fully loaded with cards and cosmetics (doors, panels, grilles, and so on), AC Delta PDU, and brackets	1720.7lb (780.5 kg)
Floor Loading	
Chassis footprint	7.2 sq ft (6689 sq cm)
Floor contact area	5.88 sq ft (5462 sq ft)
Maximum floor loading	max floor loading without cosmetics and doors 263.6 lb/sq ft max floor loading with cosmetics and doors 292.6 lb/sq ft
Chassis Cooling	2 fan trays, push-pull configuration
Chassis airflow	2700 cubic ft/ minute (76,455 liters)
Power shelf airflow	200 cubic ft/ minute (5660 liters)

## Power Specifications

Below table lists the power specifications for the LCC.

**Table 6: Line Card Chassis Power Specifications**

Description	Value
Power shelves	2 AC or 2 DC power shelves (Cannot mix AC and DC power shelves.)

Description	Value
DC power shelf	Supports up to 8 DC power modules (PMs) 6 PMs are shipped per shelf
AC power shelf	Supports up to 6 AC power modules (PMs) 5 PMs are shipped per shelf
Maximum Input Power	
DC, chassis fully loaded	19,091 Watts
AC, chassis fully loaded	19,565 Watts
Maximum Output Power	
DC, chassis fully loaded	16.80 kW
AC, chassis fully loaded	18.00 kW
Power Redundancy	
DC	2N: Up to 8 "A" battery plant feeds and up to 8 "B" battery plant feeds
AC	2N: Up to 6 "A" AC single-phase power sources and up to 6 "B" single-phase AC power sources required.
DC Input	
Nominal input voltage	-48 VDC North America-60 VDC International Range: 40 to -72 VDC
Input current	50 A max at -48 VDC 40 A max at -60 VDC 60 A at -40 VDC (maximum)
AC Input	Single-phase
Nominal input voltage	200 to 240 VAC (range 180 to 264 VAC)
Nominal line frequency	50/60 Hz (range 47 to 63 Hz)
Recommended AC service	20 A (North America) dedicated branch circuit 16 A (International) dedicated branch circuit
AC power cord length	167 in. (4.25 m)



# Line Card Chassis Environmental Specifications

Below table lists the environmental specifications for the line card chassis.

**Table 7: Line Card Chassis Environmental Specifications**

Description	Value
Temperature	Operating, nominal: 41° to 104°F (5° to 40°C) Operating, short-term: 23° to 122°F (−5° to 50°C) <sup>1</sup> Nonoperating: −40° to 158°F (−40° to 70°C)
Humidity	Operating: 5 to 90% noncondensing Nonoperating: 5 to 93% noncondensing, short-term operation
Altitude	−197 to 5906 ft (−60 to 1800 m) at 122°F (50°C), short-term Up to 13,123 ft (4000 m) at 104°F (40°C) or below
Heat dissipation	49,134 BTU per hour (maximum) DC <sup>2</sup> 56,641 BTU per hour—(maximum) AC <sup>3</sup>
Air exhaust temperature	140°F (60°C)—at room temperatures of 95 to 102°F (35 to 39°C) 158°F (70°C)—maximum exhaust temperature on a fully loaded system during worst-case operating conditions (50°C and 6000 ft altitude) <b>Note</b> Air temperature rise is 68°F (20°C) on a fully loaded system with fans running at maximum speed (5150 RPM).
Air velocity (at exhaust)	1000 ft/min (5.1m/s) at 3500 rpm 2250 ft/min(11.4m/s) at 7500 rpm <b>Note</b> Software controls the speed of the fans based on measurements from the chassis thermal sensors.
Sound power level(AC and DC power)	Fan speed 3500 RPM, temperature 80°F (27°C): 77.2 dB—modular configuration power Fan speed 5150 RPM, temperature 104°F (40°C): 88.8 dB—modular configuration power
Shock and vibration	Designed and tested to meet the NEBS shock and vibration standards defined in GR-63 Issue 3 March 2006.

- <sup>1</sup> Short-term refers to a period of not more than 96 consecutive hours and a total of not more than 15 days in 1 year. This refers to a total of 360 hours in any given year, but no more than 15 occurrences during that 1-year period.
- <sup>2</sup> Heat dissipation from the modular configuration DC power system based on maximum output power capacity at 90% efficiency.
- <sup>3</sup> Heat dissipation from the modular configuration AC power system based on maximum output power capacity at 92% efficiency. Depending on the hardware deployed at your site, your system may not consume or be capable of consuming the maximum power supplied by the power system.

## Regulatory, Compliance, and Safety Specifications

For information about the regulatory, compliance, and safety standards to which the Cisco CRS Series system conforms, see *Regulatory Compliance and Safety Information for the Cisco CRS Carrier Routing System* .



## Product IDs

This appendix provides information about the product structure, product IDs, and hardware compatibility.

The table lists system components, their product IDs (the part numbers to use to order the component), and descriptions.



**Note**

In the following tables, an equals sign (=) at the end of the product ID indicates that the component can be ordered as a spare. For those components, be sure to include the equals sign as part of the product ID.



**Note**

Although this appendix provides product IDs for routing system components, the Cisco online ordering and pricing tool has the most up-to-date information on the routing system and product IDs: <http://www.cisco.com>. CCO login is required. Enter a search term such as “CRS” to view a list of components.

- [Chassis Product IDs, page 269](#)
- [CRS Hardware Compatibility, page 272](#)

## Chassis Product IDs

Below table lists the PIDs for the LCC and its components.

**Table 8: Cisco CRS Series Enhanced 16-Slot Line Card Chassis Product IDs**

Component	Product ID	Description
Line card chassis(complete)	CRS-16-LCC-B(=) CRS-16-LCC/M-B(=) CRS-16/S-B	CRS 16 slot line card chassis for CRS-16/S-B CRS 16 slot Carrier Routing System/single-enhanced CRS 16 slot line card chassis/M-B
Switch fabric cards		

Component	Product ID	Description
Switch fabric card (single-shelf system)	CRS-16-FC/S(= CRS-16-FC140/S(= CRS-16-FC400/S(=)	S123 switch fabric cards for Cisco CRS-1 40G system S123 switch fabric cards for Cisco CRS-3 140G system S123 switch fabric cards for Cisco CRS-X 400G system (8 required for each line card chassis)
Switch fabric card (multi-shelf system)	CRS-16-FC/M(= CRS-16-FC140/M(= CRS-16-FC400/M(=)	S13 switch fabric cards for CRS-1 40G system S13 switch fabric cards for CRS-3 140G system S13 switch fabric cards for CRS-X 400G system (8 required for each line card chassis)
Route processors		
Route processor	CRS-16-RP(=)	Route processor(2 required for each line card chassis)
Performance route processor (PRP)	CRS-16-PRP-6G= CRS-16-PRP-12G=	Performance route processor (6GB memory) Performance route processor (12GB memory) (2 PRPs required for each line card chassis)
Distributed route processor (DRP)	CRS-DRP(=)	Additional route processor for the system (optional) (includes two cards, DRP CPU and DRP PLIM)
	To order DRP cards separately, use the following IDs (both cards are required for DRP operation):	
	• CRS-DRP-B-CPU(=)	DRP card only (requires DRP PLIM)
	• CRS-DRP-B-PLIM(=)	DRP PLIM only (requires DRP CPU)
Power		

Component	Product ID	Description
AC power system	CRS-16-ACKIT-M-B(= CRS-16-PWRSH-AC(=)	CRS modular power AC kit for CRS-16/S-BAC power shelf for CRS-16/S-B  CRS 16 slot AC power shelf for CRS-16/S-B
DC power system	CRS-16-DCKIT-M-B(= CRS-16-PWRSH-DC(=)	CRS modular power DC kit for CRS-16/S-BDC power shelf for CRS-16/S-B  CRS 16 slot DC power shelf for CRS-16/S-B
AC power module	CRS-PM-AC(=)	AC power module (Up to 6 required for each power shelf)
DC power module	CRS-PM-DC(=)	DC power module (Up to 8 required for each power shelf)
Alarm module	CRS-16-ALARM-B(=)	CRS 16 slot alarm board for CRS-16/S-B
AC power cord	CRS-AC-CAB-NA CRS-AC-CAB-AU CRS-AC-CAB-UK CRS-AC-CAB-EU CRS-AC-CAB-IT	AC power cord—North America AC power cord—Australia AC power cord—United Kingdom AC power cord—Europe AC power cord—Italy  <b>Note</b> Length of each power cord is 4.25 m.
Power Distribution Unit (PDU)	CRS-16-PDU-DELTA CRS-16-PDU-WYE	3-phase to single-phase AC Delta PDU for line card chassis  3-phase to single-phase AC Wye PDU for line card chassis
Cooling		
Fan tray	CRS-16-FANTRAY(=)	CRS 16 slot fan tray for CRS-16/S-B
Fan controller	CRS-16-FAN-CT(=)	CRS fan controller for CRS-16/S-B
Cable management and cosmetics		
Front cable management	CRS-16-FRONT-CM(=)	CRS 16 slot front cable management for CRS-16/S-B
Rear cable management	CRS-16-REAR-CM	CRS 16 slot chassis rear cable management for CRS-B

Component	Product ID	Description
Front door	CRS-16-DOORS-F	CRS 16 slot chassis front doors for CRS-16/S-B
Rear door	CRS-16-DOORS-R	CRS 16 slot chassis rear doors for CRS-16/S-B
Power grille	CRS-16-PW-GRILL-B(=)	CRS modular power grille for CRS-16/S-B
Chassis installation accessories (included with chassis)		
Drill hole template	CRS-16-DRILLTEMP	CRS 16 slot drill template for CRS-16/S-B
Chassis access template	CRS-16-FLOORTEMP	CRS 16 slot floor template for CRS-16/S-B
For detailed specifications for Cisco CRS routing system PLIMs, RPs and other components refer to the data sheet on: <a href="http://www.cisco.com/en/US/partner/products/ps5763/products_data_sheets_list.html">http://www.cisco.com/en/US/partner/products/ps5763/products_data_sheets_list.html</a> . CCO login is required.		
For additional information on Cisco CRS routing system SPA interface processor (SIP) and shared port adapters (SPAs), see <i>Cisco CRS SIP and SPA Hardware Installation Guide</i> .		

## CRS Hardware Compatibility

Below table lists the compatibility of 40G CRS, 140G CRS, and 400G CRS fabric, forwarding, and line card components for the LCC system.



### Note

A router with a mix of 40G, 140G, and 400G fabric cards is not a supported mode of operation. Such a mode is temporarily allowed only during the upgrade process.

Table 9: CRS Compatibility Matrix

Switch Fabric	RP/DRP	MSC/FP/LSP	PLIMs
CRS-16-FC/S	RP-A (CRS-16-RP), RP-B (CRS-16-RP-B), DRP-B (CRS-DRP-B)	CRS-MSC-B	10C768-DPSK/C 10C768-ITU/C 10C768-POS-SR 4-10GE-ITU/C 8-10GBE CRS1-SIP-800 4-10GE 42-1GE 20-1GE-FLEX 2-10GE-WL-FLEX 4-10GBE-WL-XFP 8-10GBE-WL-XFP
CRS-16-FC140/S	RP-A (CRS-16-RP), RP-B (CRS-16-RP-B), DRP-B (CRS-DRP-B)	CRS-MSC-B	10C768-DPSK/C 10C768-ITU/C 10C768-POS-SR 4-10GE-ITU/C 8-10GBE CRS1-SIP-800 4-10GE 42-1GE 20-1GE-FLEX 2-10GE-WL-FLEX 4-10GBE-WL-XFP 8-10GBE-WL-XFP
	PRP (CRS-16-PRP-6G, CRS-16-PRP-12G)	CRS-MSC-140G	14X10GBE-WL-XFP 20X10GBE-WL-XFP 1x100GBE
	PRP (CRS-16-PRP-6G, CRS-16-PRP-12G))	CRS-FP140	14X10GBE-WL-XFP 20X10GBE-WL-XFP 1x100GBE
	PRP (CRS-16-PRP-6G, CRS-16-PRP-12G)	CRS-LSP	14X10GBE-WL-XFP 20X10GBE-WL-XFP 1x100GBE
CRS-16-FC400/S (400G)	PRP (CRS-16-PRP-6G, CRS-16-PRP-12G)	CRS-MSC-X (400G)	4x100GE-LO 40x10GE-WL02x100GE-FLEX40
		CRS-FP-X (400G)	
		CRS-LSP-X (400G)	

